

Features

- 1.8kV Schottky Rectifier
- Zero Reverse Recovery Current
- High-Frequency Operation
- Temperature-Independent Switching
- Extremely Fast Switching
- Positive Temperature Coefficient on V_F

$$V_{RRM} = 1800 \text{ V}$$

$$I_F (T_c=135^\circ\text{C}) = 50 \text{ A}$$

$$Q_c = 158 \text{ nC}$$



Benefits

- Replace Bipolar with Unipolar Rectifiers
- Essentially No Switching Losses
- Higher Efficiency
- Reduction of Heat Sink Requirements
- Parallel Devices Without Thermal Runaway

Applications

- Switch Mode Power Supplies (SMPS)
- Boost diodes in PFC or DC/DC stages
- Free Wheeling Diodes in Inverter stages
- AC/DC converters



TO-247-2

Package



Part Number	Package	Marking
GC3D50170H	TO-247-2	GC3D50170

● Absolute Maximum Ratings ($T_j = 25^\circ\text{C}$)

Parameter	Symbol	Value	Unit
Reverse voltage (repetitive peak)	V_{RM}	1800	V
Reverse voltage (DC)	V_R	1800	V
Continuous forward current ($T_c=145^\circ\text{C}$)	I_F	50 ^{*1}	A
Surge non-repetitive forward current	PW=10ms sinusoidal, $T_j=25^\circ\text{C}$	150	A
	PW=10ms sinusoidal, $T_j=150^\circ\text{C}$	110	A
	PW=10 μ s square, $T_j=25^\circ\text{C}$	630	A
i^2t value	$1 \leq PW \leq 10\text{ms}$, $T_j=25^\circ\text{C}$	120	A ² s
	$1 \leq PW \leq 10\text{ms}$, $T_j=150^\circ\text{C}$	60	A ² s
Junction temperature	T_j	175	$^\circ\text{C}$
Range of storage temperature	T_{stg}	-55 to +175	$^\circ\text{C}$

*1 Limited by T_j *2 Assumes $Z_{th(j-a)}$ of 0.16 $^\circ\text{C}/\text{W}$ or less. (Pulse Width = 8.3ms)

●Electrical characteristics ($T_j = 25^\circ\text{C}$)

Parameter	Symbol	Conditions	Values			Unit
			Min.	Typ.	Max.	
DC blocking voltage	V_{DC}	$I_R=0.3\text{mA}$	1700	-	-	V
Forward voltage	V_F	$I_F=50\text{A}, T_j=25^\circ\text{C}$	-	1.65	1.95	V
		$I_F=50\text{A}, T_j=150^\circ\text{C}$	-	2.5	-	V
		$I_F=50\text{A}, T_j=175^\circ\text{C}$	-	2.8	-	V
Reverse current	I_R	$V_R=1800\text{V}, T_j=25^\circ\text{C}$	-	5	300	μA
		$V_R=1800\text{V}, T_j=150^\circ\text{C}$	-	110	-	μA
		$V_R=1800\text{V}, T_j=175^\circ\text{C}$	-	250	-	μA
Total capacitance	C	$V_R=1\text{V}, f=1\text{MHz}$	-	3100	-	pF
		$V_R=1800\text{V}, f=1\text{MHz}$	-	170	-	pF
Total capacitive charge	Q_C	$V_R=800\text{V}, di/dt=500\text{A}/\mu\text{s}$	-	158	-	nC
Switching time	t_C	$V_R=800\text{V}, di/dt=500\text{A}/\mu\text{s}$	-	39	-	ns

●Electrical characteristic curves

Fig.1 $V_F - I_F$ Characteristics

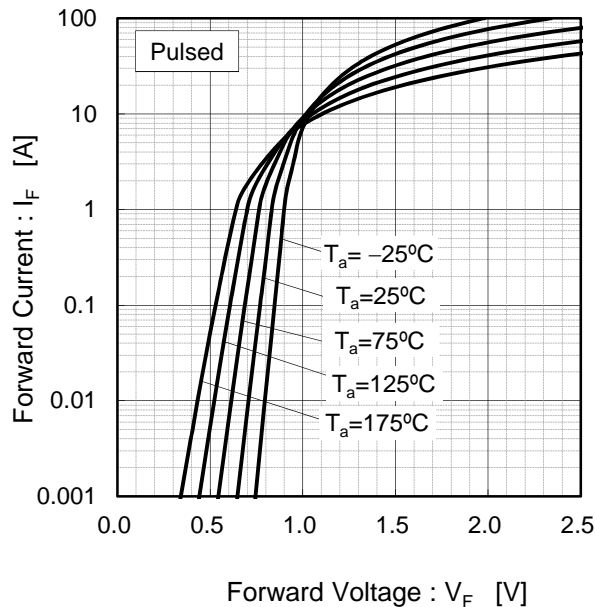

Fig.2 $V_F - I_F$ Characteristics

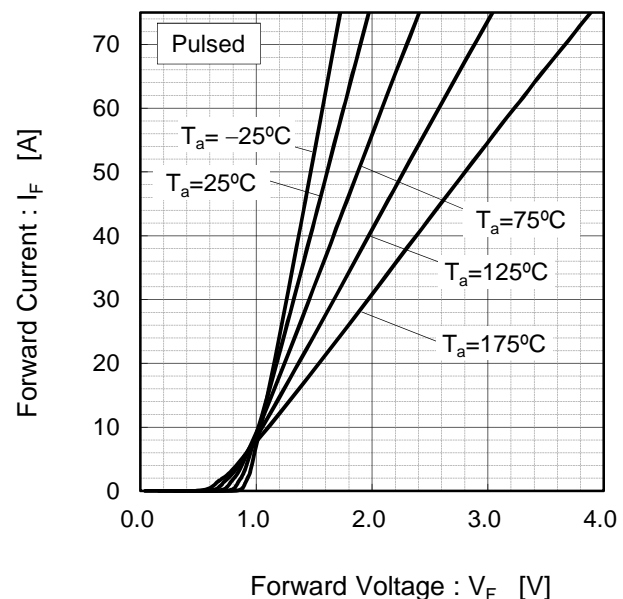

Fig.3 $V_R - I_R$ Characteristics

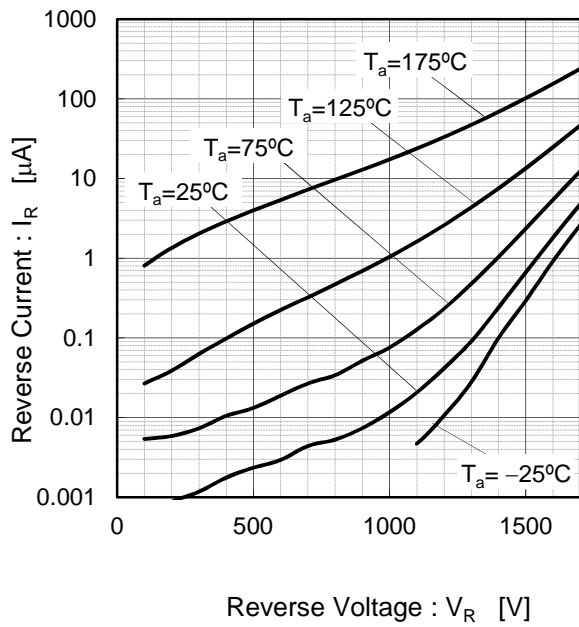

Fig.4 $V_R - C_t$ Characteristics

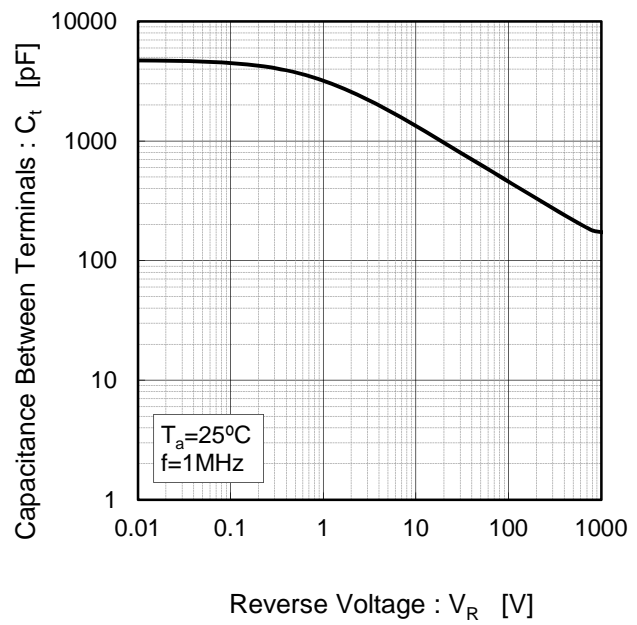

Fig.5 Surge non-repetitive forward current vs. Pulse width (Sinusoidal waveform)*

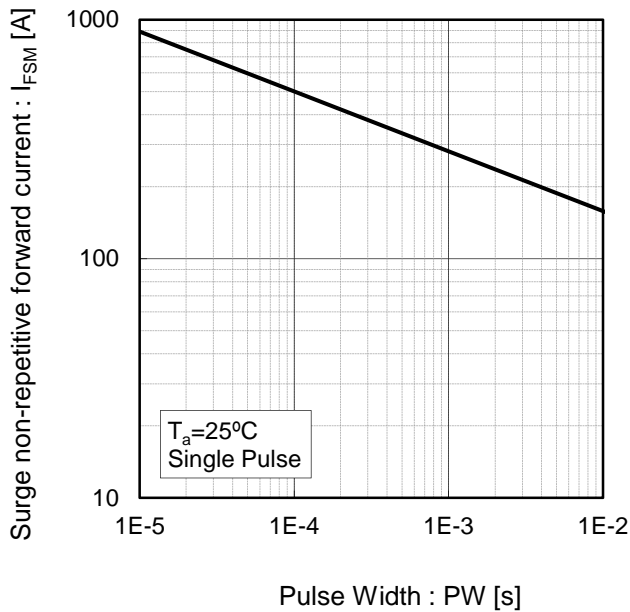
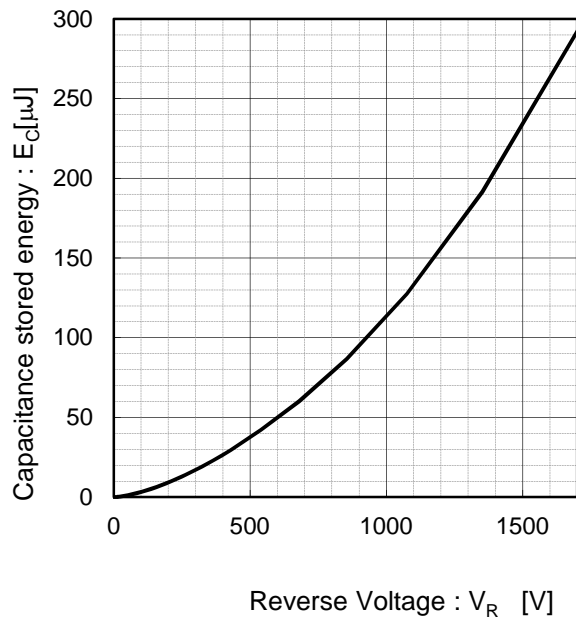
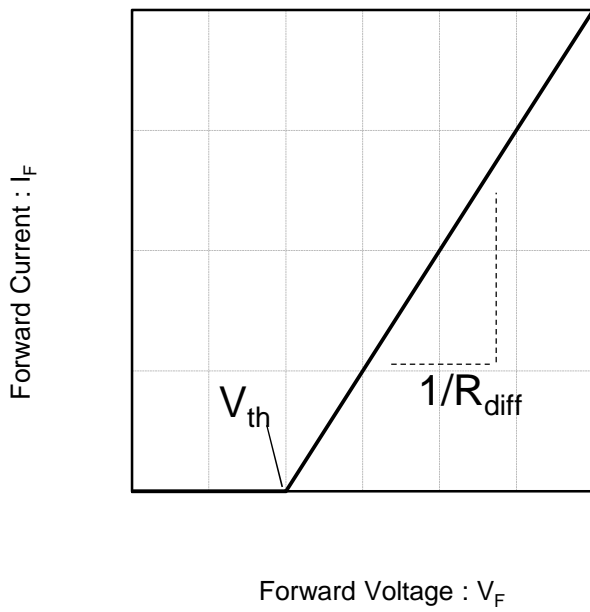

Fig.6 Typical capacitance store energy



* Assumes $Z_{th(j-a)}$ of $0.38^\circ C/W$ or less.
(Pulse Width = 8.3ms)

Fig.7 Equivalent forward current curve



$$V_F = V_{th} + R_{diff} I_F$$

$$V_{th}(T_j) = a_0 + a_1 T_j$$

$$R_{diff}(T_j) = b_0 + b_1 T_j + b_2 T_j^2$$

Symbol	Typical Value	Unit
a_0	9.21E-01	V
a_1	- 1.52E-03	V/°C
b_0	1.20E-02	Ω
b_1	8.13E-05	$\Omega/^\circ\text{C}$
b_2	5.64E-07	$\Omega/^\circ\text{C}^2$

T_j in °C; $-55^\circ\text{C} < T_j < ^\circ\text{C}$; $I_F < 100\text{A}$

Package Dimensions

Package TO-247-2

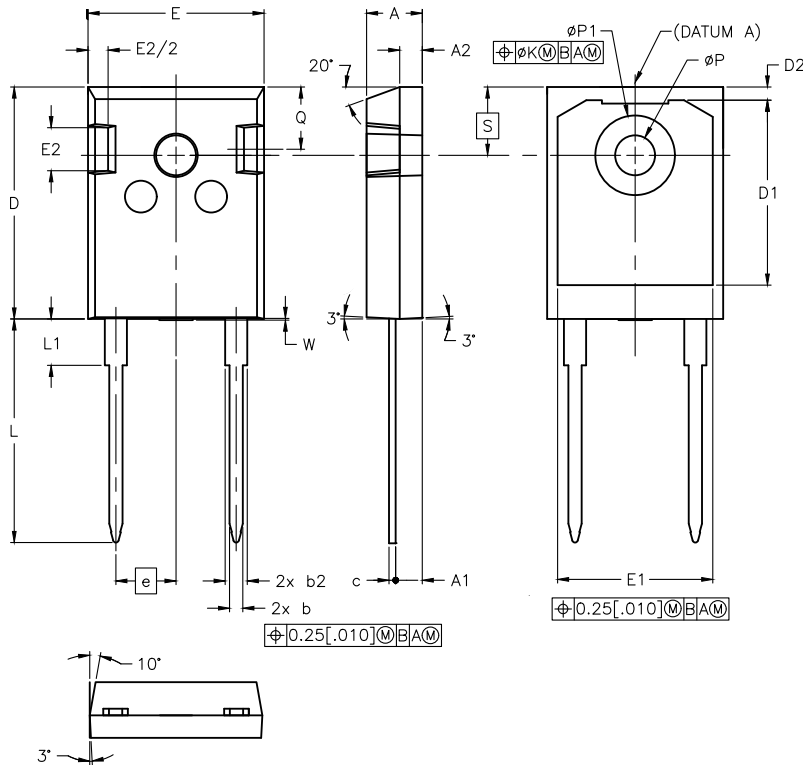

POS	Inches		Millimeters	
	Min	Max	Min	Max
A	.190	.205	4.70	5.31
A1	.087	.102	2.21	2.59
A2	.059	.098	1.50	2.49
b	.039	.055	0.99	1.40
b2	.065	.094	1.65	2.39
c	.015	.035	0.38	0.89
D	.819	.845	20.80	21.46
D1	.515	-	13.08	-
D2	.020	.053	0.51	1.35
E	.620	.640	15.49	16.26
E1	.530	-	13.46	-
E2	.135	.157	3.43	3.99
e	.214		5.44	
ϕK	.010		0.25	
L	.780	.800	19.81	20.32
L1	-	.177	-	4.50
ϕP	.140	.144	3.56	3.66
$\phi P1$.278	.291	7.06	7.39
Q	.212	.244	5.38	6.20
S	.243		6.17	
W	-	.006	-	0.15



Recommended Solder Pad Layout

