

FMC SATA RAID board [AB09-FMCRAID]

Manual [Ver1.2E]

Introduction

Thank you for choosing FMC SATA RAID board [Part Number: AB09-FMCRAID] (“RAID board” in this manual.)

The RAID board is compliant with FMC standard and provides 10 SATA channels at maximum by high speed serial interface in HPC(High Pin Count)-FMC so that user can build SATA RAID prototype system.

The RAID board mounts 5 SATA interface at both of component and solder side of the board and can directly connect with 10 2.5”-SATA drive. User can supply power to the connected SATA drive via 4-pin ATX Standard power connector.

On-board 150MHz low-jitter differential oscillator will supply high-quality reference SATA clock to the refclk input of FPGA.

Following figure-1 shows the RAID board with 5 2.5”-SATA drives and connected FPGA board. (User can mount another 5 2.5”-SATA drives on the solder side of the RAID board so that the RAID board can support up to 10 SATA drives at maximum.



Figure-1: AB09-FMCRAID board

Board Appearance

The RAID board size is 69mm width and 87mm length.

Following figure-2 and figure-3 shows component side and solder side appearance respectively.

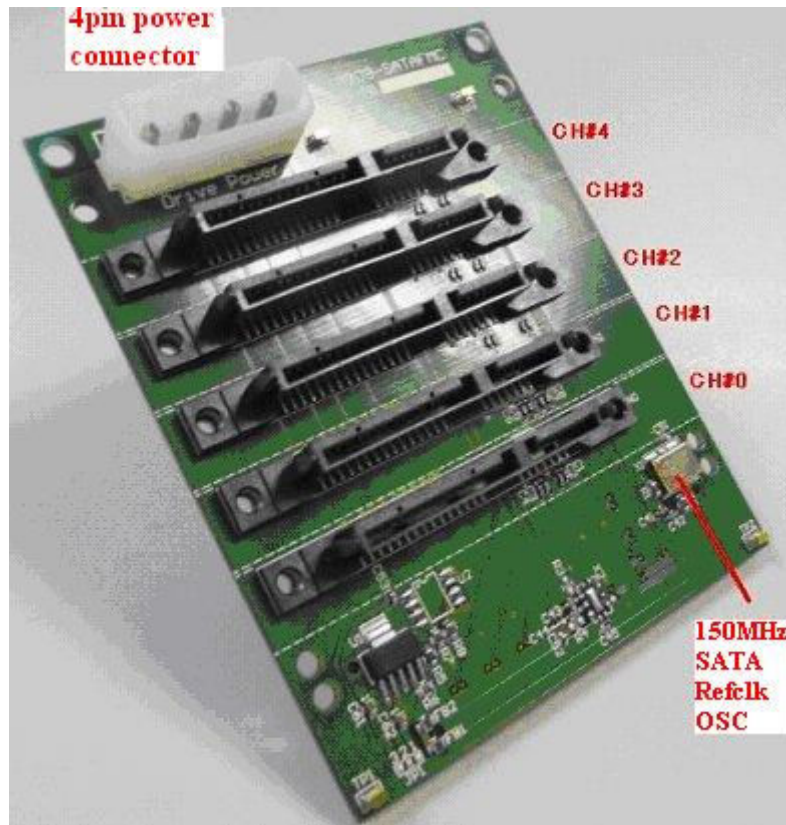

Figure-2: AB09-FMCRAID component side

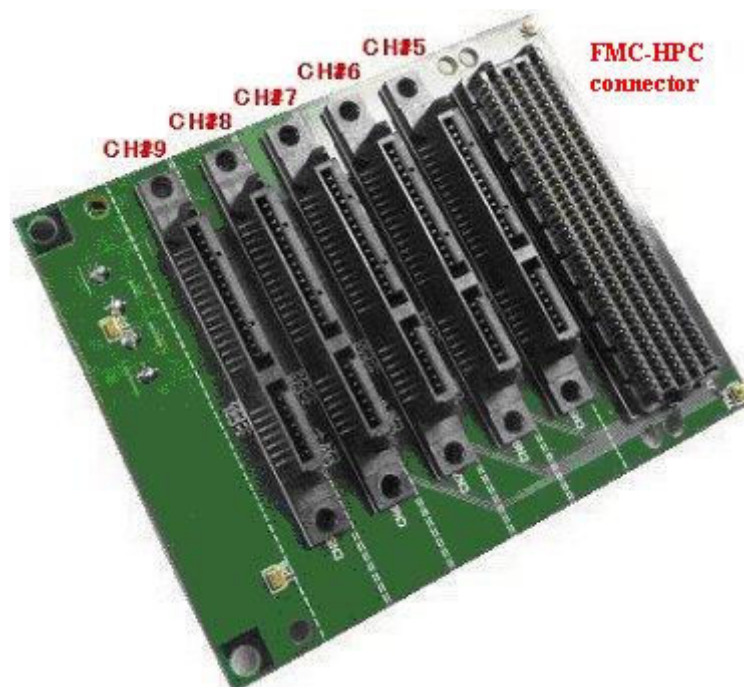

Figure-3: AB09-FMCRAID solder side



Connection to the FPGA board

Connect the RAID board with FMC-HPC connector on the FPGA board.

For 2.5"-SATA drive connection, user can directly connect SATA drive with 5 SATA channels of CH#0 to CH#4 on the component side and another 5 channels of CH#5-CH#9 on the solder side.

Use 4-pin ATX Standard power connector for SATA drive power supply.

User must check that both the RAID board and FPGA board is powered off when remove or connect SATA drive, RAID board, or FPGA board.

To connect 3.5"-SATA drive, use SATA general extension cable. Following general extension cable is suitable for 3.5" usage.

Vendor: AREA (Setagaya Denki)

Product Number: AR-S005S

URL : <http://www.area-powers.jp/denki/cable/s005s.htm>

Vendor: AINEX

Product Number: SAT-15EXPA

URL : <http://www.ainex.jp/products/sat-15expa.htm>

When user want to assign SATA channel of the RAID board as a SATA Device to connect with SATA Host-PC, use above extension cable along with the following crossover adapter provided from DesignGateway.

Vendor: DesignGateway

Product Number: AB02-CROSSOVER

URL : <http://www.design-gateway.com/ABseries.html>

Pin Assignment

Pin assignment of FMC-HPC on the RAID board is listed following table-1.

FMC HPC Pin#	FMC definition	RAID Bd. connection	RAID Bd. signal name	FMC HPC Pin#	FMC definition	RAID Bd. connection	RAID Bd. signal name
C2	DP0_C2M_P	CN0-S2	HT0P (TX Pos)	C6	DP0_M2C_P	CN0-S6	HR0P (RX Pos)
C3	DP0_C2M_N	CN0-S3	HT0N (TX Neg)	C7	DP0_M2C_N	CN0-S5	HR0N (RX Neg)
A22	DP1_C2M_P	CN1-S2	HT1P (TX Pos)	A2	DP1_M2C_P	CN1-S6	HR1P (RX Pos)
A23	DP1_C2M_N	CN1-S3	HT1N (TX Neg)	A3	DP1_M2C_N	CN1-S5	HR1N (RX Neg)
A26	DP2_C2M_P	CN2-S2	HT2P (TX Pos)	A6	DP2_M2C_P	CN2-S6	HR2P (RX Pos)
A27	DP2_C2M_N	CN2-S3	HT2N (TX Neg)	A7	DP2_M2C_N	CN2-S5	HR2N (RX Neg)
A30	DP3_C2M_P	CN3-S2	HT3P (TX Pos)	A10	DP3_M2C_P	CN3-S6	HR3P (RX Pos)
A31	DP3_C2M_N	CN3-S3	HT3N (TX Neg)	A11	DP3_M2C_N	CN3-S5	HR3N (RX Neg)
A34	DP4_C2M_P	CN4-S2	HT4P (TX Pos)	A14	DP4_M2C_P	CN4-S6	HR4P (RX Pos)
A35	DP4_C2M_N	CN4-S3	HT4N (TX Neg)	A15	DP4_M2C_N	CN4-S5	HR4N (RX Neg)
A38	DP5_C2M_P	CN5-S2	HT5P (TX Pos)	A18	DP5_M2C_P	CN5-S6	HR5P (RX Pos)
A39	DP5_C2M_N	CN5-S3	HT5N (TX Neg)	A19	DP5_M2C_N	CN5-S5	HR5N (RX Neg)
B36	DP6_C2M_P	CN6-S2	HT6P (TX Pos)	B16	DP6_M2C_P	CN6-S6	HR6P (RX Pos)
B37	DP6_C2M_N	CN6-S3	HT6N (TX Neg)	B17	DP6_M2C_N	CN6-S5	HR6N (RX Neg)
B32	DP7_C2M_P	CN7-S2	HT7P (TX Pos)	B12	DP7_M2C_P	CN7-S6	HR7P (RX Pos)
B33	DP7_C2M_N	CN7-S3	HT7N (TX Neg)	B13	DP7_M2C_N	CN7-S5	HR7N (RX Neg)

Table-1: HPC-FMC pin assignment of AB09-FMCRAID board

FMC HPC Pin#	FMC definition	RAID Bd. connection	RAID Bd. signal name	FMC HPC Pin#	FMC definition	RAID Bd. connection	RAID Bd. signal name
B28	DP8_C2M_P	CN8-S2	HT8P (TX Pos)	B8	DP8_M2C_P	CN8-S6	HR8P (RX Pos)
B29	DP8_C2M_N	CN8-S3	HT8N (TX Neg)	B9	DP8_M2C_N	CN8-S5	HR8N (RX Neg)
B24	DP9_C2M_P	CN9-S2	HT9P (TX Pos)	B4	DP9_M2C_P	CN9-S6	HR9P (RX Pos)
B25	DP9_C2M_N	CN9-S3	HT9N (TX Neg)	B5	DP9_M2C_N	CN9-S5	HR9N (RX Neg)
D4	GBTCLK0_M2C_P	(via C42) X1-5	150MHz RefClk Positive	D5	GBTCLK0_M2C_N	(via C41) X1-4	150MHz RefClk Negative

Table-1: HPC-FMC pin assignment of AB09-FMCRAID board (cont'd)

Note: There is no clock supply at GBT_CLK1_M2C_P/N (Pin# B20/B21 of FMC-HPC) from the RAID board.

Differential Impedance

Differential Impedance of SATA signal trace on the RAID board is controlled to 100ohm to keep signal quality. Following figure-4 shows TDR measurement result of CH#3 differential impedance of the RAID board. As in this result, measured impedance is about 95-98ohm so mostly adjusted to 100ohm. (The light blue position means PCB trace part on the RAID board.)



Figure-4: AB09-FMCRAID differential impedance (CH#3)
(Measured by Agilent Network Analyzer E5071C)



Disclaimer

DesignGateway is exempted from any damage to the connected SATA device or FPGA board.
DesignGateway does not guarantee transfer speed performance.

[Inquiry]

URL : <http://www.design-gateway.com/>

Email : <mailto:sales@design-gateway.com>

Revision History

Revision	Date	Description
1.2E	12-Jul-2012	Release English manual

1_HPC

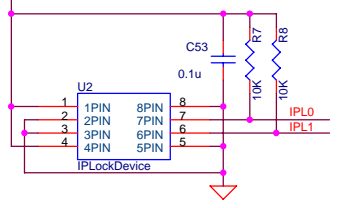
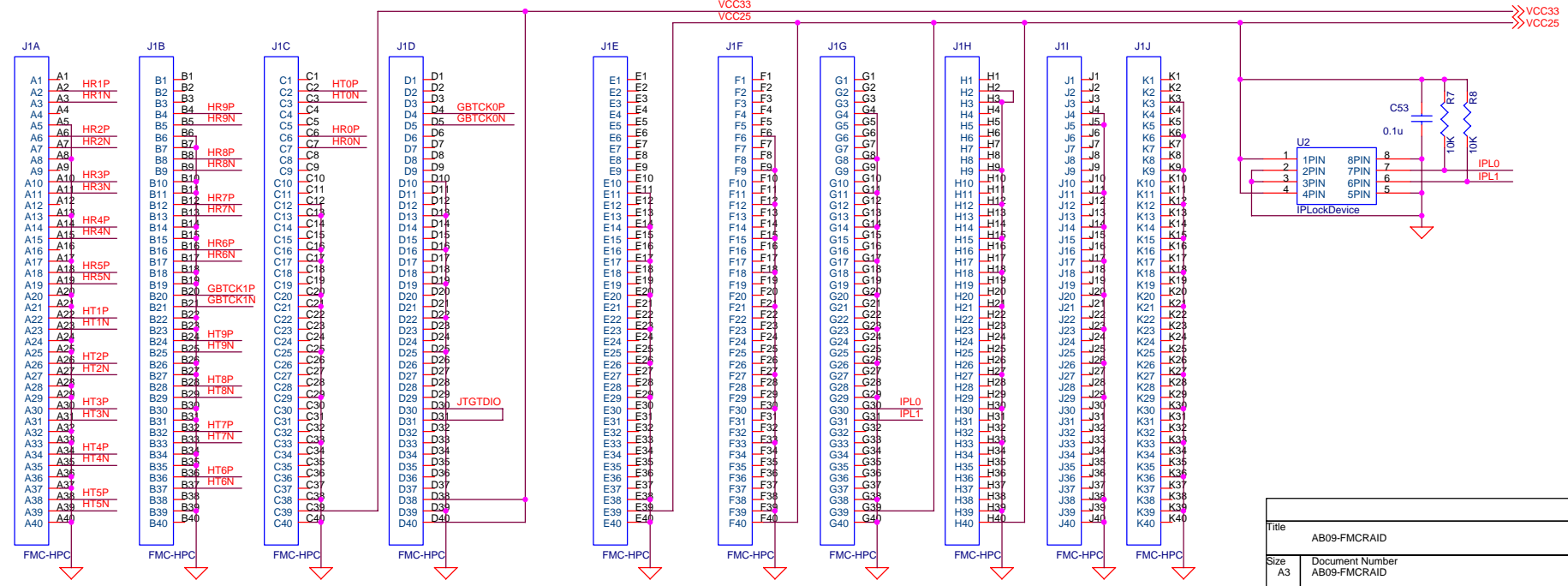
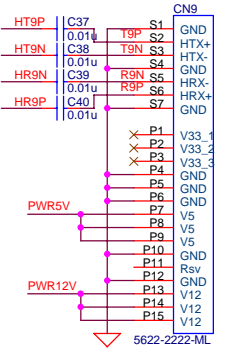
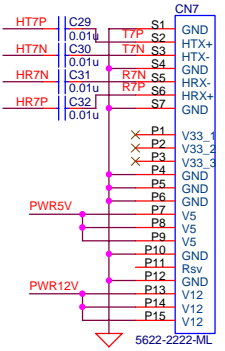
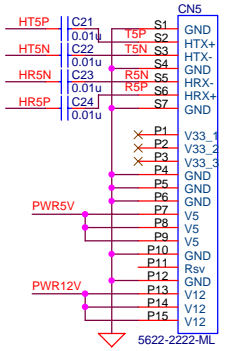
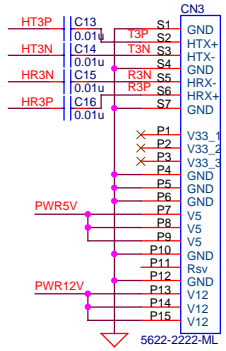
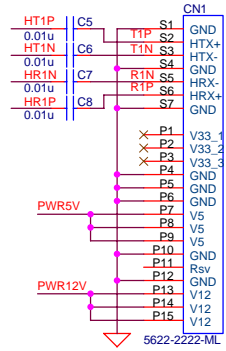
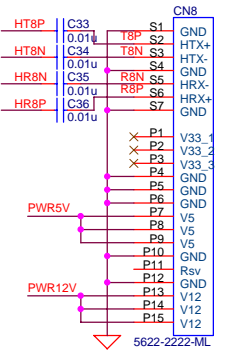
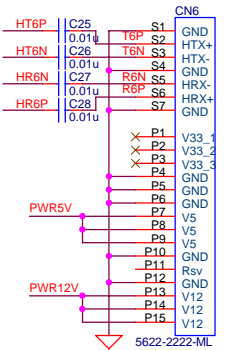
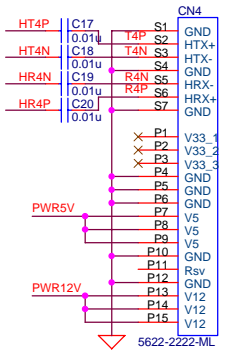
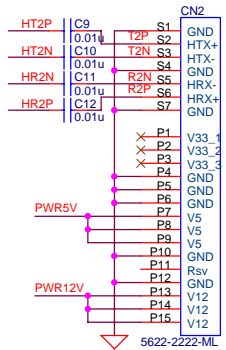
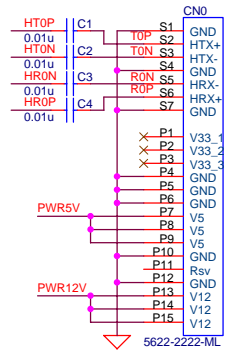
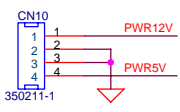

Title			AB09-FMCRaid
Size	Document Number		Rev
A3	AB09-FMCRaid		1.0
Date:	Tuesday, October 18, 2011	Sheet	1 of 2

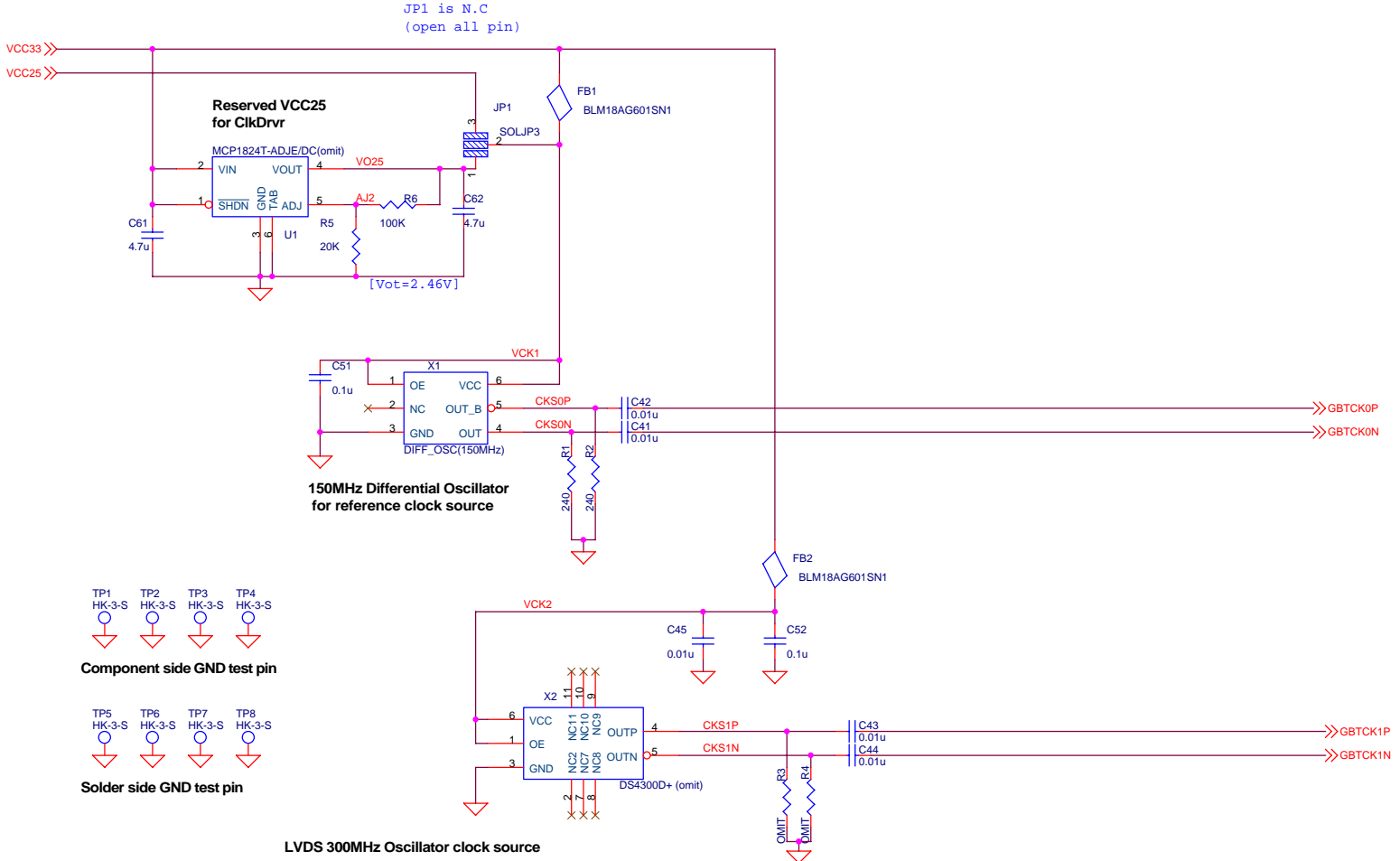

Title		
AB09-FMCRAID		
Size	Document Number	Rev
A3	AB09-FMCRAID	1.0
Date:	Tuesday, October 18, 2011	Sheet 2 of 2

Mouser Electronics

Authorized Distributor

Click to View Pricing, Inventory, Delivery & Lifecycle Information:

[Design Gateway:](#)

[AB09-FMCRAID](#)