

## Common Mode Power line Choke FC-HLF2018-10mH-10A-LF

### Features:

1. High current common mode choke
2. Broadband suppression for common mode noise
3. Custom designs on request
4. Inductance range: 15.0mH
5. Insulation Test Voltage: 1500VAC
6. turns Ratio: 1:1
7. Rated Current: 10A
8. Operating temperature: -40 °C to +125 °C

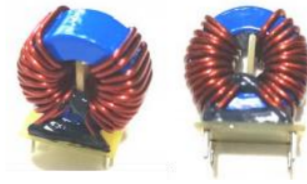

### 1. Dimensions:mm

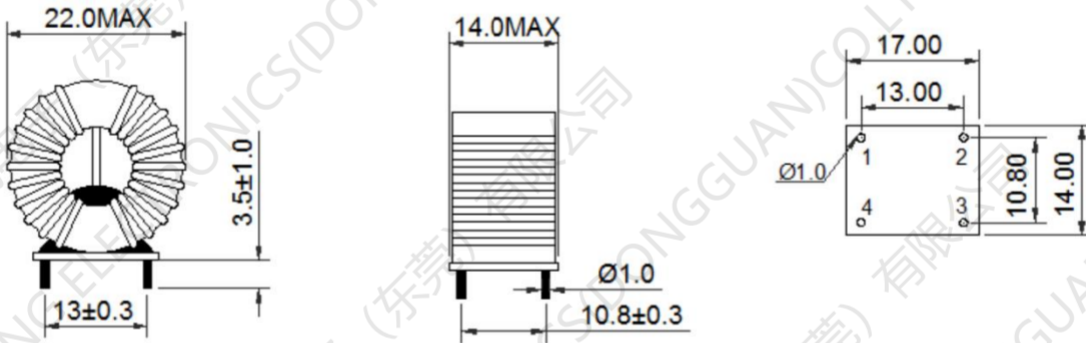

### 2. Schematic:

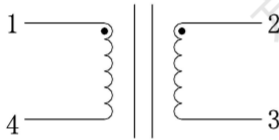

### 3. Recommended Land Pattern: mm

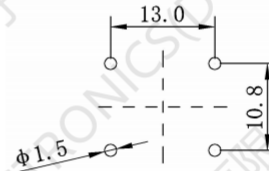

### 4. Electrical Properties

NO.	ITEMS	MEASURING POINT	TECHNICAL DATA	TEST CONDITION	INSTRUMENT
1	Inductance	N1=N2	10.0mH/MIN~15.0mH/typ	1KHz, 0.3V, 25°C	HP4284A
2	IR	COIL~CORE	100Mohm MIN	DC500V	MF2511
3	turns Ratio	N1:N2	1:1	20KHz, 1V, 25°C	TH3250
4	DCR	N1=N2	9.5mΩ TYP~15.0mΩ MAX	25°C	CH502
5	Insulation Test Voltage	COIL~COIL	1500V/AC	50Hz 3mA 5S	CJ2670
		COIL~CORE	500V/AC	50Hz 3mA 5S	CJ2670
6	Rated Current	N1/N2	10A/min	ΔT≦40°C (Ta=25°C)	6240

Ambient temperature : -40°C to +85°C  
 Operating temperature: -40°C to +125°C