

RoHS 2.0

REV.	ECN NO.	DESCRIPTION	DATE	DESIGN

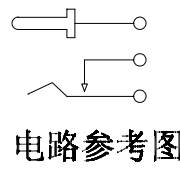
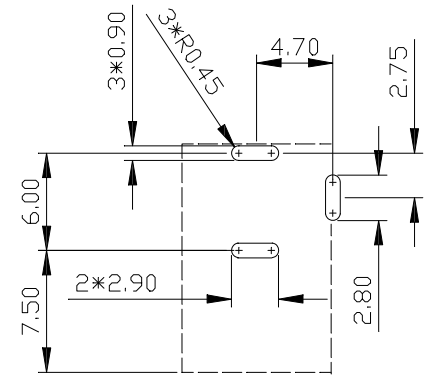
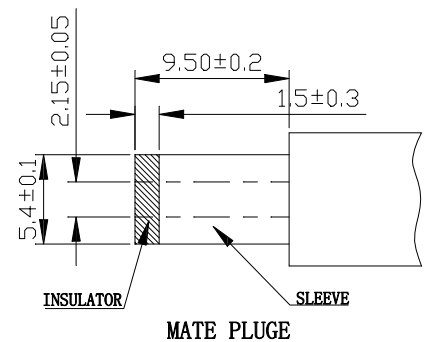
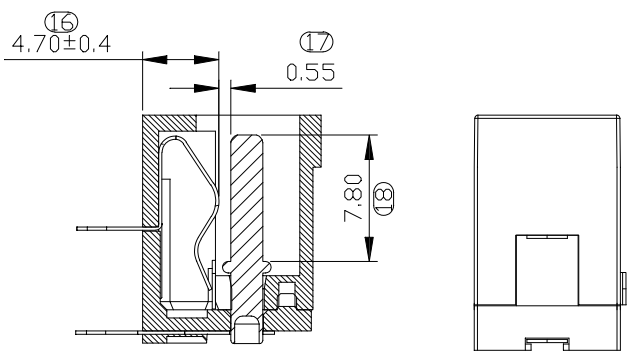
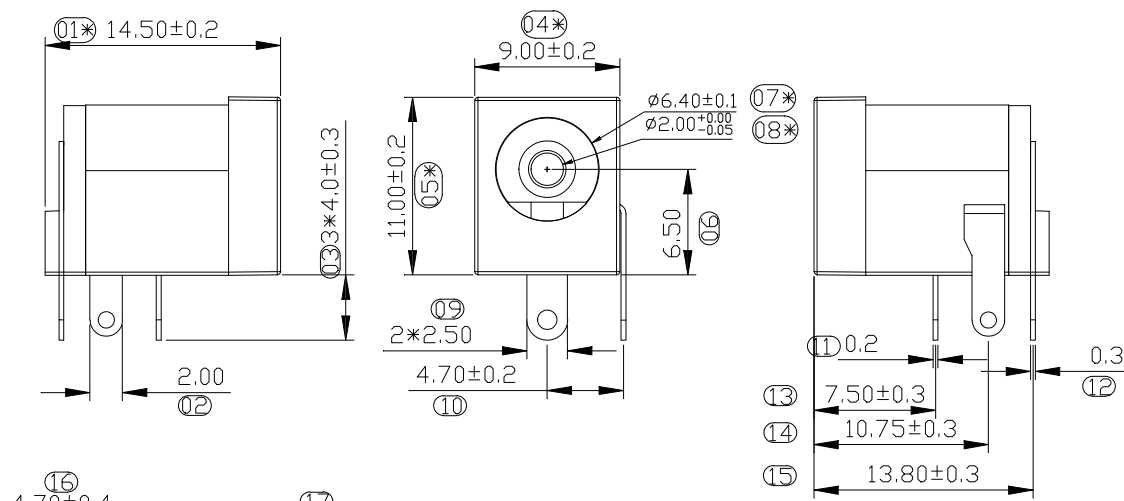

NOTES:

- MATERIAL:
 - HOUSING: PBT ,COLOR IS BLACK,UL94V-0;
 - CONTACT: BRASS ;
- FINISH: PLATED OVER NI&SN;
- RECINNEBDED PCB THICKNESS: 1.60mm MIN;
- ELECTRICAL:
 - VOLTAGE RATING: 30V DC ;
 - CURRENT RATING: 2A ;
 - CONTACT RESISTANCE: 35MILLIOHMS MAX.;
 - WITHSTAND VOLTAGE: 500 VAC RMS 50(60)Hz,1MIN.;
 - INSULATION RESISTANCE: 100MEGOHMS MIN @500V DC;
- MECHANICAL:
 - MATING FORCE: 25N MAX.;
 - UNMATING FORCE:3~25N ;
 - OPERATING LIFE: 5000 CYCLES MIN.;
- SALT SPRAY TEST: 24H;
- SOLDERABILITY: 245±5°C,5±0.5S;
- RESISTANCE TO SOLDER: 260±0.5°C,10±1S;
- ENVIRONMENTAL:
 - STORAGE TEMPERATURE RANGE: -40°C~+85°C;
 - OPERATION TEMPERATURE RANGE: -25°C~+70°C;
- THE MARK WITH "*" IS THE KEY INSPECTION DIMENSION FOR QC.

E	芯针	黄铜H65	镀镍锡	
D	PIN脚	黄铜H65	镀镍锡	
C	弹片	磷铜	镀镍锡	
B	后塞	PBT	黑色	
A	底座	PBT	黑色	
序号	品名	材质	电镀/颜色	备注

深圳市华灿天禄电子有限公司

UNLESS OTHERWISE, GENERAL TOLERANCE: X.xxx ±0.10 X.xx ±0.20 X.x ±0.30	NAME:	DC-005(Φ2.0铜芯)		P/N: HC-DC-005-2.0HT	
	THIRD ANGLE PROJECTION	UNIT: mm	SCALE: 1:1	SIZE: A4	SHEET: 1/1
ANGULAR: X.xx° ±1° X.x° ±3° X.° ±5°	DRAWN: Lihui	CHECKED: Yangguangrong	APPROVED Tangguanlin		