

# 468 Series

## 1206 Slo-Blo® Fuse

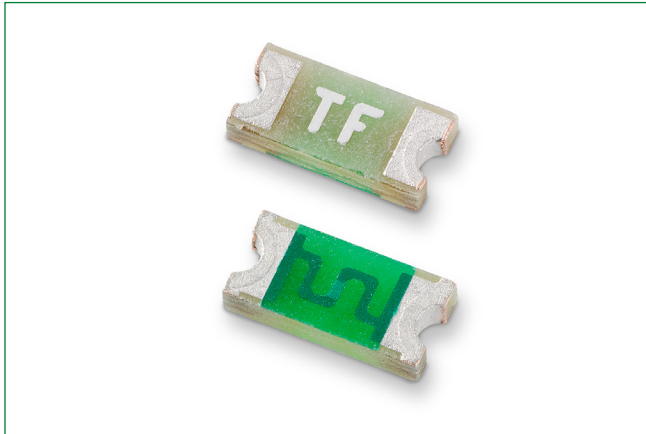

### Description

The 468 Series Slo-Blo® Surface Mount Fuse (SMF) is a small (1206 size) thin-film device designed for secondary protection of circuits used in space constrained applications such as hand-held portable electronic devices.

This series is 100% lead-free and meets the requirements of the RoHS directive. New Halogen-Free 468 Series fuses are available—to order use the “HF” suffix. See Part Numbering section for additional information.

### Features and Benefits

- Complies with electronic industry environmental standards for lead reduction.
- Package is visually distinct from fast-acting version for easy identification.
- Product is compatible with lead-free solders and higher temperature profiles.
- Top side marking allows visual verification of amperage rating.
- Time delay feature withstands high inrush currents and prevents nuisance openings.
- Lead-free, halogen-free and ROHS compliant.

### Applications

Secondary protection for space constrained applications:

- Cell phones
- Battery packs
- Digital cameras
- DVD players
- Hard disk drives.

### Additional Information



Resources



Accessories



Samples

### Electrical Characteristics for Series

% of Ampere Rating	Opening Time at 25°C
100%	4 hours, Minimum
200%	1 sec., Min.; 120 sec., Max.
300%	0.05 sec., Min.; 1.5 sec., Max
800%	0.0015 sec., Min.; 0.05 sec., Max.

### Agency Approvals

Agency	Agency File Number	Ampere Range
cRU US	E10480	0.5A - 3A
SP	29862	0.5A - 3A

### Electrical Specifications by Item

Ampere Rating (A)	Amp Code	Max Voltage Rating (V)	Interrupting Rating	Nominal Cold Resistance (Ohms) <sup>1</sup>	Nominal Melting I <sup>2</sup> t (A <sup>2</sup> sec)	Nom Voltage Drop (mV)	Nom Power Dissipation (W)	Agency Approvals	
								cRU US	SP
0.50	.500	63	50A @63 VAC/VDC	0.27000	0.0310	156.77	0.0784	x	x
1.00	001.	63		0.0790	0.1270	94.70	0.0947	x	x
1.50	01.5	63		0.0440	0.2880	82.32	0.1235	x	x
2.00	002.	63	35A @63 VAC 50A @63 VDC	0.0325	0.5060	77.27	0.1545	x	x
2.50	02.5	63		0.0240	1.0110	73.92	0.1848	x	x
3.00	003.	32	50A @32 VAC/VDC	0.01950	1.2700	72.95	0.2189	x	x

1. Measured at 10% of rated current, 25°C.

2. Measured at rated voltage.

# 468 Series

## 1206 Slo-Blo® Fuse

### Temperature Re-rating Curve

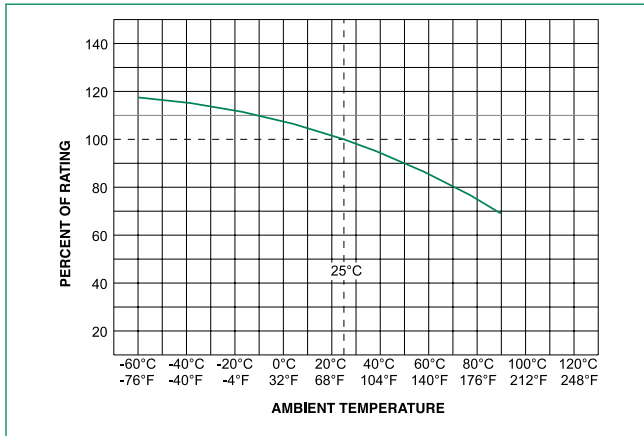

**Note:**

1. Rerating depicted in this curve is in addition to the standard derating of 25% for continuous operation.

**Example:**

For continuous operation at 70 degrees celsius, the fuse should be derated as follows:

$$I = (0.75)(0.80)I_{\text{RAT}} = (0.60)I_{\text{RAT}}$$

2. The temperature derating curve represents the nominal conditions. For questions about temperature derating curve, please consult Littelfuse technical support for assistance.

### Average Time Current Curves

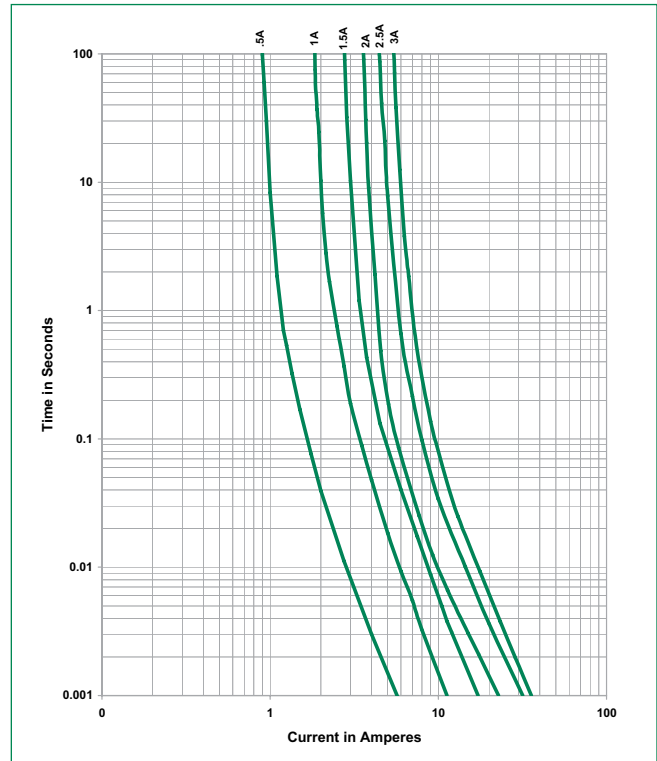

### Soldering Parameters

<b>Reflow Condition</b>		Pb – Free assembly
<b>Pre Heat</b>	- Temperature Min ( $T_{s(\text{min})}$ )	150°C
	- Temperature Max ( $T_{s(\text{max})}$ )	200°C
	- Time (Min to Max) ( $t_p$ )	60 – 180 secs
<b>Average ramp up rate (Liquidus Temp (<math>T_L</math>) to peak)</b>		5°C/second max
<b><math>T_{s(\text{max})}</math> to <math>T_L</math> - Ramp-up Rate</b>		5°C/second max
<b>Reflow</b>	- Temperature ( $T_L$ ) (Liquidus)	217°C
	- Temperature ( $t_L$ )	60 – 150 seconds
<b>Peak Temperature (<math>T_p</math>)</b>		260 <sup>+0/-5</sup> °C
<b>Time within 5°C of actual peak Temperature (<math>t_p</math>)</b>		20 – 40 seconds
<b>Ramp-down Rate</b>		5°C/second max
<b>Time 25°C to peak Temperature (<math>T_p</math>)</b>		8 minutes Max.
<b>Do not exceed</b>		260°C

<b>Wave Soldering</b>	260°C, 10 seconds max.
-----------------------	------------------------

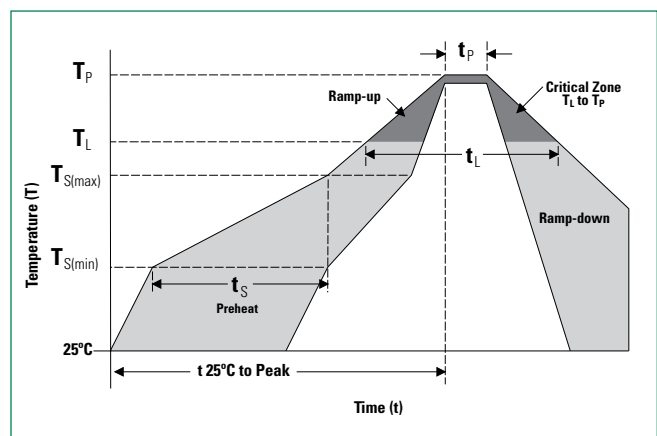

# 468 Series

## 1206 Slo-Blo® Fuse

### Product Characteristics

<b>Materials</b>	<b>Body:</b> Epoxy Substrate <b>Terminations:</b> 100% Tin over Nickel over Copper <b>Element Cover Coat:</b> Conformal Coating
<b>Operating Temperature</b>	-55°C to 90°C. Consult temperature re-rating curve chart. For operation above 90°C please contact Littelfuse
<b>Thermal Shock</b>	Withstands 5 cycles of - 50°C to 125°C
<b>Humidity</b>	MIL-STD-202, Method 103, Condition D

<b>Vibration</b>	Withstands 10-55 Hz per MIL-STD-202, Method 201 and 10-2000 Hz at 20 g's per MIL-STD-202, Method 204, Condition D
<b>Insulation Resistance (After Opening)</b>	Greater than 10,000 ohms.
<b>Resistance to Soldering Heat</b>	MIL-STD-202, Method 210, Condition D

### Dimensions

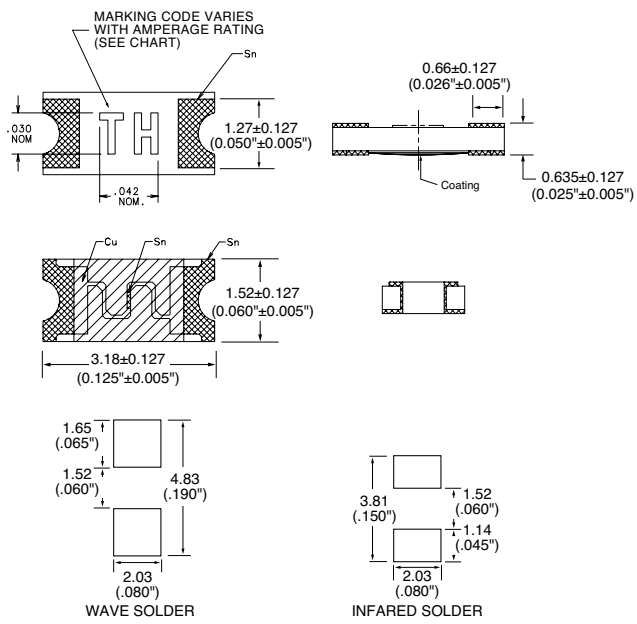

### Part Marking System

Amp Code	Marking Code
.500	<b>TF</b>
001.	<b>TH</b>
01.5	<b>TK</b>
002.	<b>TN</b>
02.5	<b>TO</b>
003.	<b>TP</b>

### Part Numbering System

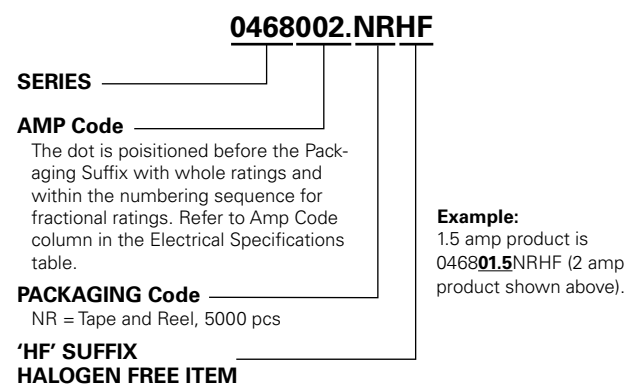

### Packaging

Packaging Option	Packaging Specification	Quantity	Quantity & Packaging Code
Tape & Reel – 8mm tape	EIA-481 Rev. D (IEC 60286, part 3)	5000	NR

**Disclaimer Notice** - Littelfuse products are not designed for, and shall not be used for, any purpose (including, without limitation, automotive, military, aerospace, medical, life-saving, life-sustaining or nuclear facility applications, devices intended for surgical implant into the body, or any other application in which the failure or lack of desired operation of the product may result in personal injury, death, or property damage) other than those expressly set forth in applicable Littelfuse product documentation. Warranties granted by Littelfuse shall be deemed void for products used for any purpose not expressly set forth in applicable Littelfuse documentation. Littelfuse shall not be liable for any claims or damages arising out of products used in applications not expressly intended by Littelfuse as set forth in applicable Littelfuse documentation. The sale and use of Littelfuse products is subject to Littelfuse Terms and Conditions of Sale, unless otherwise agreed by Littelfuse. Information furnished is believed to be accurate and reliable. However, users should independently evaluate the suitability of and test each product selected for their own applications. Littelfuse products are not designed for, and may not be used in, all applications. Read complete Disclaimer Notice at [www.littelfuse.com/disclaimer-electronics](http://www.littelfuse.com/disclaimer-electronics).