

General Description

The SM8002 high efficiency 1.5MHz synchronous buck converter operates over a wide input voltage range of 2.5V to 5.5V, and can deliver an output current up to 2A. It integrates a top MOSFET and a bottom MOSFET with very low $R_{DS(ON)}$ to minimize conduction loss. The 1.5MHz pseudo-constant switching frequency enables using small external inductor and capacitor values.

The SM8002 uses constant-off time and peak current mode control strategy to achieve fast transient response and high efficiency at light loads. It also provides cycle-by-cycle current limit protection, output under voltage protection and over temperature protection.

Only the input and output capacitors, inductor, feedback resistor divider and feedforward capacitor need to be selected for the targeted application specifications.

The SM8002 is available in a compact SOT23-5 package.

Features

- Low $R_{DS(ON)}$ for Internal MOSFETs: 130mΩ Top, 85mΩ Bottom
- Wide Input Voltage Range: 2.5V ~ 5.5V
- Up to 2A Output Current
- $\pm 1.5\%$ 0.6V Reference
- PFM Light Load Operation for High Efficiency
- Internal Soft-Start Limits the Inrush Current
- 1.5MHz Switching Frequency Minimizes the External Components
- Constant Off-time and Peak Current Mode Control to Achieve Fast Transient Responses
- 100% Dropout Operation
- Output Auto Discharge Function
- Cycle-by-Cycle Peak Current Limit Protection
- Hic-Cup Mode Output Under Voltage Protection
- Auto-Recovery Mode Over Temperature Protection
- Input Under Voltage Lockout (UVLO)
- RoHS-Compliant and Halogen-Free
- Compact Package: SOT23-5

Applications

- Set-Top Box
- USB Dongle
- Media Player
- Smart Phone

Typical Application

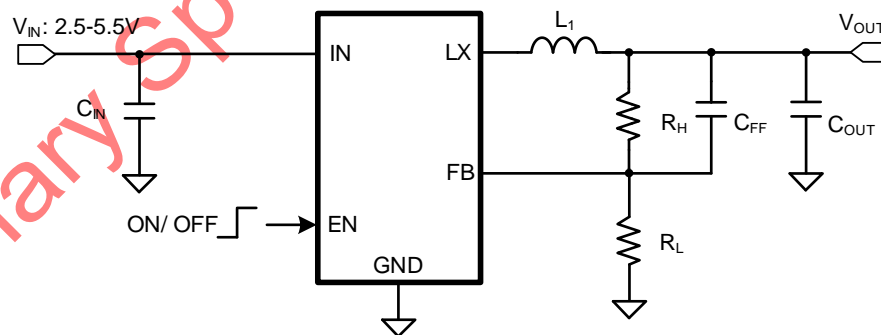

Figure 1. Schematic Diagram



Ordering Information

Ordering Part Number	Package type	Top Mark
SM8002AAX	SOT23-5 RoHS Compliant and Halogen Free	KPXxyz

x = year code, y = week code, z = lot number code

Pinout (top view)

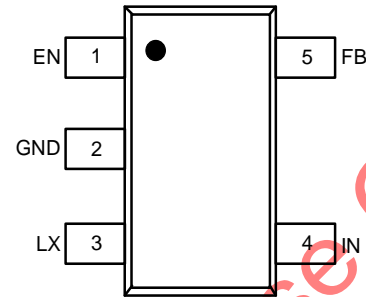

Pin Description

Pin No	Pin Name	Pin Description
1	EN	Enable pin. Pull this pin high to turn on the device and pull this pin low to turn off the device. Do not leave this pin floating.
2	GND	Ground pin.
3	LX	Inductor pin. Connect this pin to the switching node of inductor.
4	IN	Input pin. Decouple this pin from the GND pin with at least a 10µF ceramic capacitor.
5	FB	Output feedback pin. Connect this pin to the center point of the output resistor divider as shown in Figure 1. $V_{OUT} = 0.6 \times (1 + R_H/R_L)$.

Block Diagram

Figure2. Block Diagram

Absolute Maximum Ratings

Parameter (Note 1)	Min	Max	Unit
IN, LX	-0.3	6	V
EN, FB	-0.3	IN + 0.6	
LX, 40ns duration	-3	7	
Junction Temperature, Operating	-40	150	°C
Lead Temperature (Soldering, 10s)		260	
Storage Temperature	-65	150	

Thermal Information

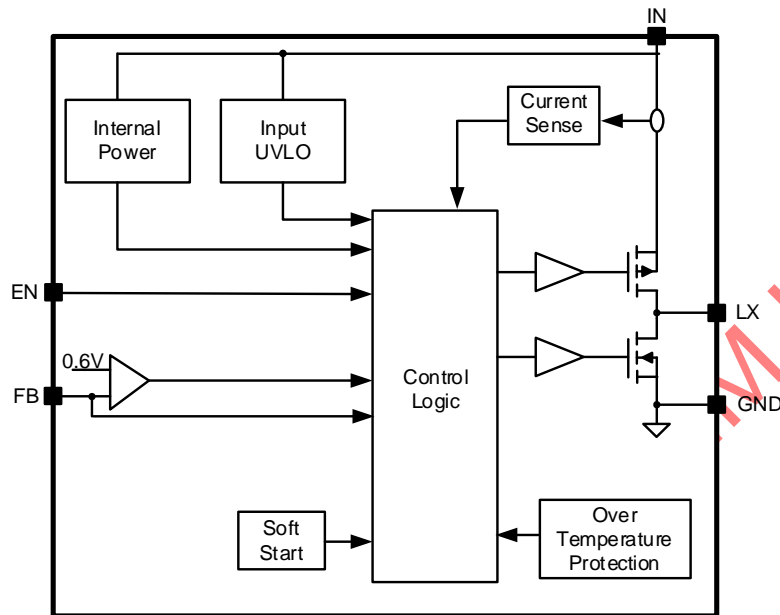
Parameter (Note 2)	Typ	Unit
θ_{JA} Junction-to-Ambient Thermal Resistance	TBD	°C/W
θ_{JC} Junction-to-Case Thermal Resistance	TBD	
P_D Power Dissipation $T_A = 25^\circ\text{C}$	TBD	W

Recommended Operating Conditions

Parameter (Note 3)	Min	Max	Unit
Input Voltage	2.5	5.5	V
Output Voltage	0.6	5.5	
Continuous Output Current		2	A
Ambient Temperature	-40	85	°C
Junction Temperature	-40	125	

Electrical Characteristics
 $(V_{IN} = 5V, V_{OUT} = 1.8V, L = 1.0\mu H, C_{OUT} = 10\mu F, T_J = 25^\circ C, I_{OUT} = 0.5A \text{ unless otherwise specified})$

Parameter	Symbol	Test Conditions	Min	Typ	Max	Unit	
Input	Voltage Range	V_{IN}	2.5		5.5	V	
	UVLO Rising Threshold	$V_{IN,UVLO}$	V_{IN} rising		2.5		
	UVLO Hysteresis	$V_{IN,HYS}$		0.15			
	Quiescent Current	I_Q	$I_{OUT} = 0A, V_{FB} = V_{REF} \times 105\%$		50	70	μA
	Shutdown Current	I_{SHDN}	$V_{EN} = 0V$		0.1	1	
Output	Voltage Range	V_{SET}	0.6		5.5	V	
	FB Reference Voltage	V_{REF}	0.591	0.6	0.609		
	Turn On Delay Time	$t_{ON,DLY}$	From EN high to LX starts switching (Note 4)		0.5		ms
	Soft-Start Time	t_{SS}	V_{OUT} from 0% to 100% V_{SET} (Note 4)		1		
	Discharge on Resistance	R_{DIS}			50		Ω
Enable (EN)	Input Voltage High	$V_{EN,H}$	1.2			V	
	Input Voltage Low	$V_{EN,L}$			0.4		
MOSFET	Top MOSFET $R_{DS(ON)}$	$R_{DS(ON),TOP}$		130		m Ω	
	Bottom MOSFET $R_{DS(ON)}$	$R_{DS(ON),BOT}$		85			
	Top MOSFET Current Limit Threshold	$I_{LMT,TOP}$		3.5		A	
Frequency	Switching Frequency	f_{SW}	$I_{OUT} = 0.5A, CCM$		1.5	MHz	
	Minimum On-Time	$t_{ON,MIN}$	(Note 4)		60	ns	
	Maximum Duty Cycle	D_{MAX}	(Note 4)	100		%	
OTP	Temperature	T_{OTP}	(Note 4)		150	$^\circ C$	
	Temperature Hysteresis	T_{HYS}	(Note 4)		20		

Note 1: Stresses beyond the “Absolute Maximum Ratings” may cause permanent damage to the device. These are stress ratings only. Functional operation of the device at these or any other conditions beyond those indicated in the operational sections of the specification is not implied. Exposure to absolute maximum rating conditions for extended periods may affect device reliability.

Note 2: θ_{JA} is measured in the natural convection at $T_A = 25^\circ C$ on a 6cmx6cm size, two-layer Silergy Evaluation Board with 2-oz copper. Pin 3 of SOT23-5 package is the case position for θ_{JC} measurement.

Note 3: The device is not guaranteed to function outside its operating conditions.

Note 4: Guaranteed by design.

SOT23-5 Package Outline Drawing

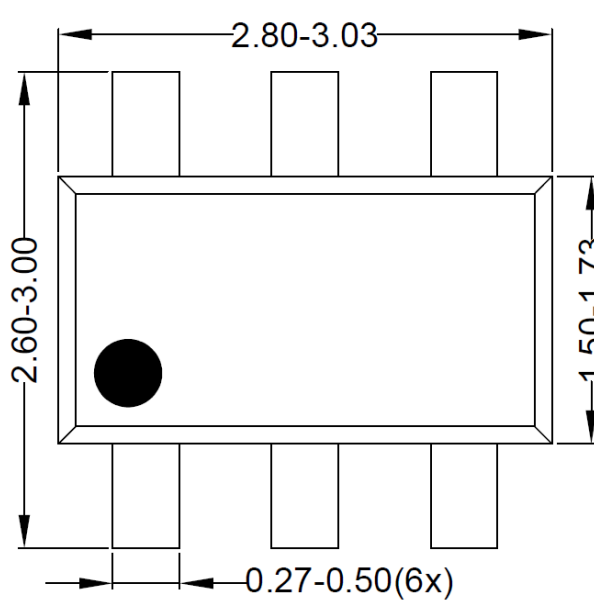

Top view

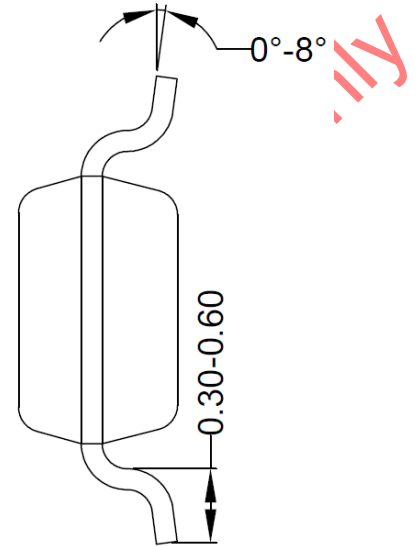

Side view

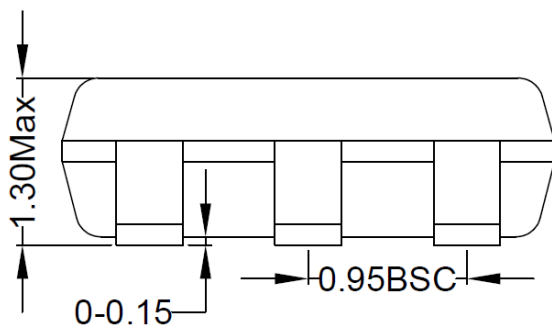

Front view

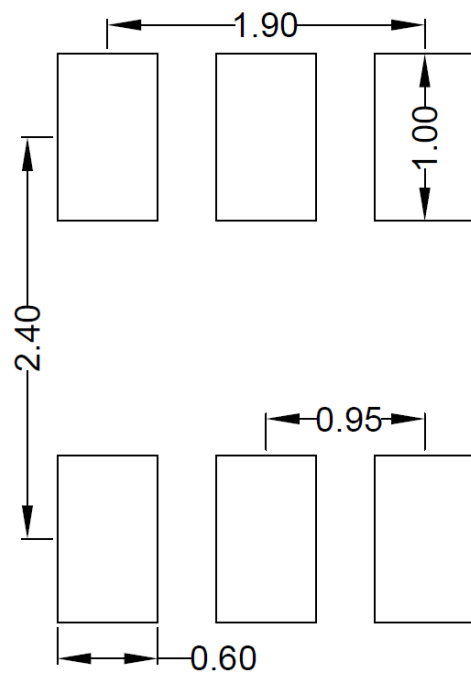

**Recommended PCB pad Layout
(Reference only)**

Pr

Notes: All dimension in millimeter and exclude mold flash & metal burr.

Tape and Reel Specification

1. Tape orientation SOT23-5

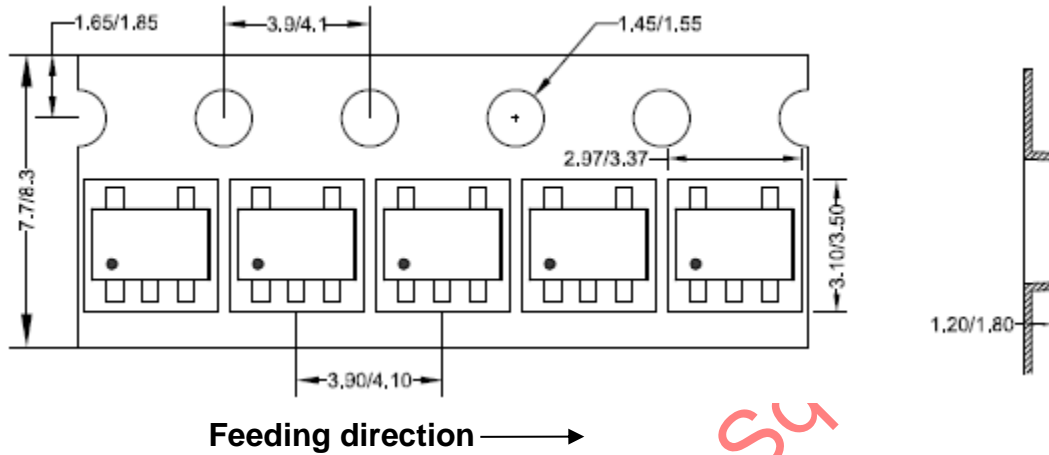

2. Carrier Tape and Reel specification for packages

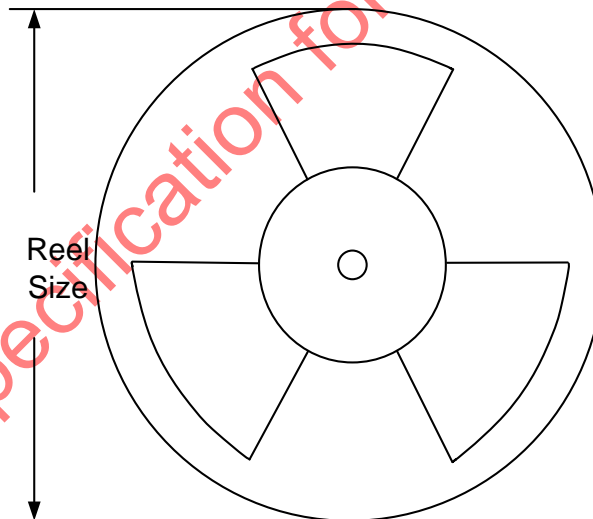

Package type	Tape width (mm)	Pocket pitch(mm)	Reel size (Inch)	Trailer length(mm)	Leader length (mm)	Qty per reel
SOT23-5	8	4	7	280	160	3000