Product Specifications

Type	: Chip Capacitor
Model	: CPH3225A

This is a "Standard Spec sheet " which is a general documentation for your evaluation.

Before we will start to supply this part to you, we would like you to ask us the formal version of this spec sheet.

We will issue the formal specification sheet for you. (Basically the contents is the same as this one.)

We would like you to put your signature on it to state your approval of the specification, and send it back to us.

It will be a kind of contract between you and us.

Seller: Seiko Instruments Inc.
Electronic Components Business Unit
Micro-Energy Division

Address: 1-8, Nakase, Mihamaku, Chiba-shi, Chiba 261-8507, Japan

Responsible person: Sales Dep.
General Manager
Shigeo Niwa

Signature: _____
(Not applicable to submit this specification by e-mail)

History of Revision

No.	Described	Details of Change	Checked	Issue Date
01	Development dept.	Initial release	QA Dep.	Jun.18, 2010

Manufacturer information

Company name: **Seiko Instruments Inc.**
Electronic Components Business Unit
Micro-Energy Division

Address: 45-1, Aza-Matsubara, Kami-ayashi, Aoba-ku, Sendai-shi, Miyagi,
Japan, postal code: 989-3124

Responsible Quality Assurance Office Manager
person: Kazuhiro Shimizu

Signature: _____
(Not applicable to submit this specification by e-mail)

E-mail address: sii.sendai-qa01@sii.co.jp

Index

Contents	page
Cover page for the customer approval	1
History of revision Manufacturer Information	2
Index	3
1 Application	4
2 Model	4
3 Chemical System and Structure	4
4 Nominal Specifications	4
5 Characteristics	5
6 Measuring Methods	6
7 Test Methods	8
8 Mounting and Rework Methods	9
9 Marking	9
10 Inspection (Outgoing and Incoming)	9
11 Package Specifications	10
12 In case of quality trouble	10
13 Operation of this Specification	10

Appendix

Chemical System and Structure
 Capacitor drawing
 Reflow Profile
 Drawing of Emboss Carrier Tape
 Capacitor position in emboss tape
 Taping specifications
 Package specifications
 Precautions for Your Safety

1. Application

This specification applies to the Chip-type Capacitor.

2. Model

Refer to the Model in this cover page.

3. Chemical System and Structure

Refer to Appendix “Chemical System and Structure”.

4. Nominal Specifications

		Model
No.	Characteristics	CPH3225A
4-1	Operating temperature range	-20°C to +60°C (Detailed : follow to Cp.#5)
4-2	Charging voltage	Max. 3.3V
4-3	Maximum discharge Current	10uA
4-4	Nominal Capacity Discharge capacity (3.3V to 2.0V, 5uA) Electrostatic capacity	4.0uAh 11mF
4-5	Internal impedance	250 ohm
4-6	Size Length Width Height	3.2±0.1mm 2.5±0.1mm 0.9±0.1mm
4-7	Standard mass	25mg
4-8	Recommended Storage conditions Temperature Humidity	+10°C to +30°C 60%RH or less
4-9	The voltage at the delivery time	0.3V Max.

5. Characteristics

No.	Characteristics	Model	Test Methods	Measuring Methods
		CPH3225A		
1	Capacity (initial)		7-1	6-2
	24°C	3.5uAh or more		
	-20°C	2.1uAh or more		
	60°C	2.1uAh or more		
2	Internal impedance (initial)		7-1	6-3
	24°C	850 ohm or less		
	-20°C	8000 ohm or less		
	60°C	500 ohm or less		
3	Float Charge Characteristics		7-2	6-2
	Capacity	2.8uAh or more		
	Internal impedance	8000 ohm or less		
4	High Temperature and High Humidity Storage Characteristics		7-3	6-2
	Capacity	2.8uAh or more		
	Internal impedance	1500 ohm or less		
5	Charge / Discharge Cycle Characteristics		7-4	6-2
	Capacity	2.8uAh or more		6-3
	Internal impedance	4000 ohm or less		7-4

6. Measuring Methods

6-1. Measuring Environment, Meters and Equipment

6-1-1: Environment

Testing and Measuring must be conducted under the environment of the normal temperature (24+/-2°C) and the normal humidity (65+/-20%RH), if not specified.

6-1-2: Size

For measuring size JIS B 7503 (Dial gauge), JIS B 7507 (Vernier caliper) and JIS B 7502 (External micrometer) or meter with same grade in accuracy must be used.

6-1-3: DC Voltmeter

Voltmeter with class 0.2 of JIS C 1102 (Electric indicating instrument) or meter with same or better grade in accuracy, and its input impedance is over 10Mohm must be used.

6-1-4: DC Ammeter and AC Ammeter

Ammeter with class 0.2 of JIS C 1102 (Electric indicating instrument) or meter with same or better grade in accuracy must be used.

6-1-5: Resistance

Resistance should include all resistance in external circuit and its tolerance must be within +/-0.5%.

6-1-6: Initialization of capacitor

All electrical measurements must be conducted after 3 minutes of short-circuit.

6-2. Capacity

Figure 6-2 shows the capacity measurement circuit at the charge-discharge, and Table 6-2 shows the charge-discharge condition.

6-2-1. Charge

The SW is set to 1 and the charge begins. And the SW is opened when the charge time gets to charging time: T_c .

6-2-2. Discharge

The SW is set to 2, and the discharge begins. The discharge current at this time is assumed to be I_d (uA). When the voltage of the capacitor: V_{cap} becomes a cutoff voltage V_{cut} , the switch is opened. The time to reach the cutoff voltage: V_{cut} is assumed to be T_{cut} (hour).

$$\text{Capacity} = I_d \times T_{cut} \text{ (uAh)}$$

<Fig. 6-2-1 : Measuring Circuit>

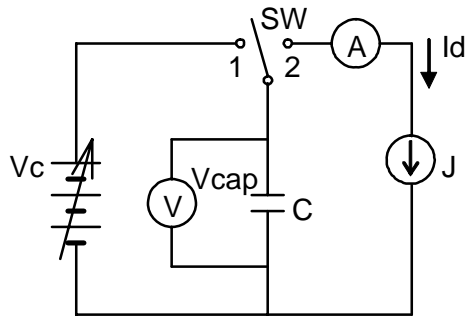

- C : Capacitor
- Vc : DC Constant-voltage Power
- Vcap : Voltage of capacitor
- SW : Switch
- J : Constant-current Load Device
- Id : Discharge current

<Fig. 6-2-2 : Charging and discharging Curve>

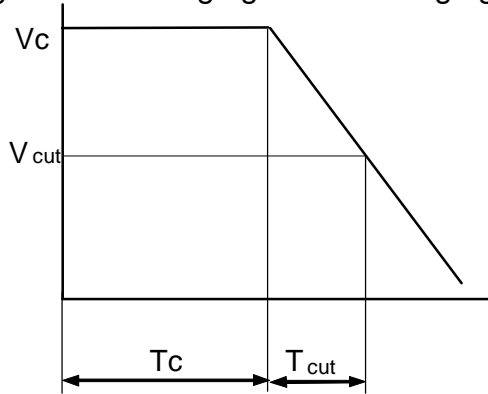

<Table: 6-2>

Model	Charging voltage Vc (V)	Charging Time Tc (hour)	Discharging Current Id(uA)	Cutoff Voltage Vcut (V)
CPH3225A	3.3	2.0	5	2.0

6-3. Internal Impedance

Measure by alternating method with frequency 1kHz.

6-4. Appearance

- After Test : Use microscope, which has magnification of from 10 to 15.
- General : Naked eye

7. Test Methods

7-1. Temperature Characteristic Test

Measure electrical characteristics after exposing capacitor to each temperature atmosphere for 2 hours.

Temperature : -20+/-2°C, +24+/-2°C, +60+/-2 °C

7-2. Float Charge Characteristics Test

Measure electrical characteristics and conduct appearance check after charging capacitor continuously with charging voltage of Vc.

Model	Vc	Temperature	period
CPH3225A	3.3V	60+/-2°C	480 hours

7-3. High Temperature and High Humidity Storage Characteristics Test

Measure electrical characteristics and check the appearance after storage of capacitor.

Model	Temperature	Humidity	period
CPH3225A	60+/-2°C	90+/-3%RH	480 hours

7-4. Charge / Discharge Cycle Characteristics Test

Charge : Apply Vc, 5 minutes.

Discharge : Short 1 minutes.

Cycles : 10000 cycles

Model	Vc
CPH3225A	3.3V

After 10000 cycles, capacity is measured by the method of 6-2.

8. Mounting and Rework Methods

8-1. Mounting methods

It is possible to reflow soldering. Execute it when the capacitor has the voltage of 0.3V or less. Refer to "Reflow Profile" attached.

8-2. Rework methods

Manual soldering using soldering iron for rework

Max. tip temperature : 350°C +/- 10°C

Max. exposure time : 20s

Max. capacitor voltage : 0.3V

*Example of method of decrease in voltage of capacitor

Please make the capacitor short-circuit between + and - terminal for 3 minutes if there is 0.3V or more voltage of the capacitor.

9. Marking

9-1. Marking

Following items are indicated on the surface of capacitor.

(1) Positive polarity (+) (2) Name of Manufacturer or monogram

9-2. Lot number: 5digits

Example: *7901

*: our own number, and might be omitted.

7: manufactured in 2007

9: manufactured in September

Abbreviation of month Jan. (1), Feb. (2),..., Sep. (9)

Oct. (0), Nov. (Y), Dec. (Z)

01: our own number, and might be omitted.

10. Inspection (Outgoing and Incoming)

10-1. Lot composition

Lot must be composed within the same manufacturing conditions.

10-2. Outgoing Inspection

Seiko Instruments Inc. shall do outgoing inspection before shipping. The inspection items are as below table. The inspection results shall be submitted immediately for the customer request.

No	Characteristics	Inspection levels	Frequency
1	Capacity (initial)	n=6, c=0	per lot
2	Internal Impedance (initial)	n=6, c=0	per lot
3	Leakage Resistance	n=10, c=0	per lot

10-3. Incoming Inspection

The customer should do incoming inspection within 30 days from the receiving day.

If defects are find out at the incoming inspection, the customer immediately should notify to Seiko Instruments Inc, in writing, with the defective products, for replacement request.

11. Package specifications

Examples of the tray etc. for wrapping, wrapping specification, and packing specification are shown in the following.

11-1. Wrapping

Refer to “Drawing of Emboss Carrier Tape” and “Taping specifications”.

11-2. Wrapping and packing

Refer to “Package Specifications”.

12. In case of quality trouble

The warranties set forth herein are the only warranties on the Products.

The liabilities of Seiko Instruments Inc. in connection with the Products under these specifications are expressly limited to the replacement of defective Products.

13. Operation of this Specification

13-1. Agreement

Before these specifications being revised, the agreement, of the customer, seller and manufacturer, is required.

13-2. Negotiation

If some accident not specified on these specifications occurs, the customer, seller and manufacturer must negotiate in order to solve the problem faithfully.

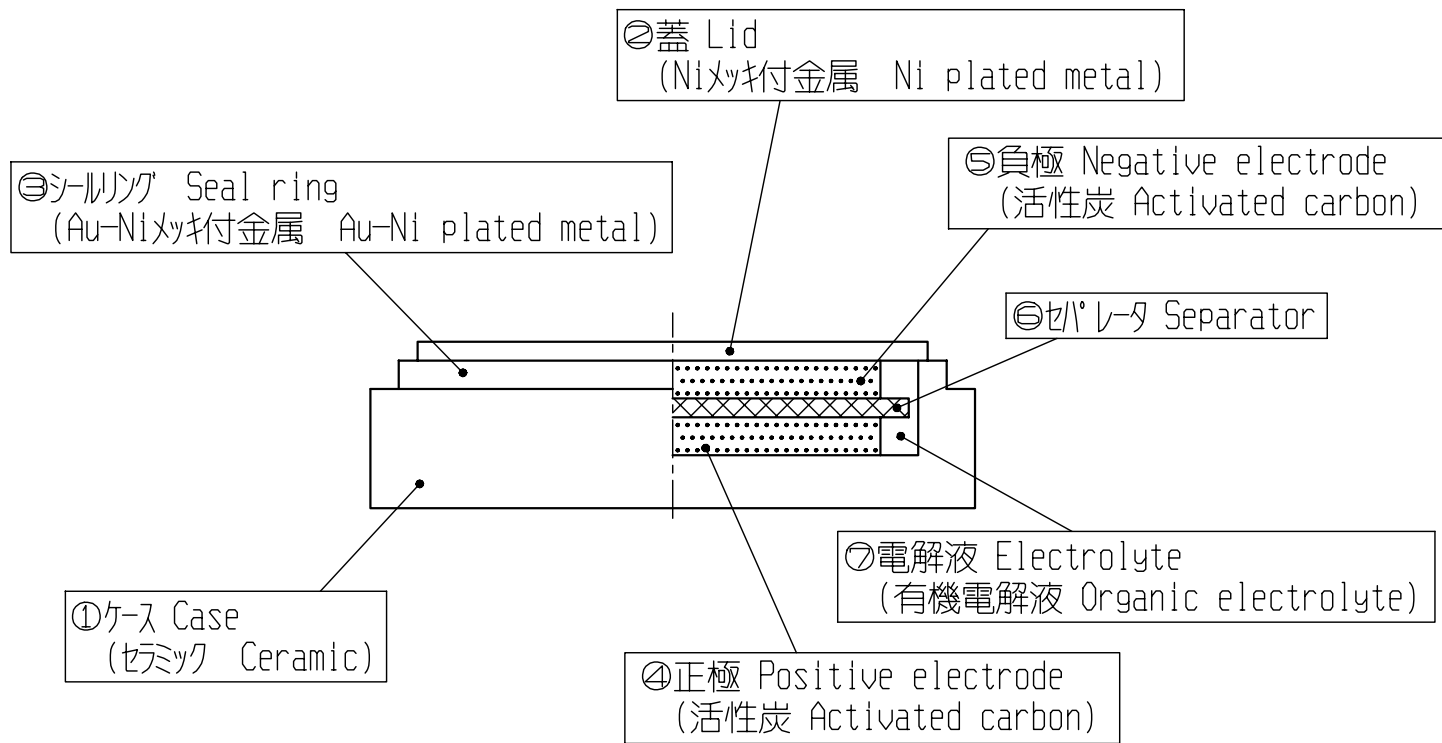

				File No. ファイル番号	30480000-CP000-1
				Material 材料	
				Process 処理	
				Date 日付	Nov. 07, 2007
E07A-048	Nov. 09, 2007	設定		Name 名称	Chemical system and structure 化学システムと構造
History 履歴	Date 日付	Reason 理由			
Approved 承認	Checked 検査	Drawn 製図	Scale 尺度	Cal. No. 製品番号	CP****
冨塚	/	尾形	Unit 単位	1=1mm	Drw. No. 図面番号
			Rev. 改訂	1	

<Notes>

The upper surface of the capacitor is made of the metal. And it is connected with the negative terminal.

<注意>

キャパシタの上面は全て金属で出来ており、負極端子に接続されています。

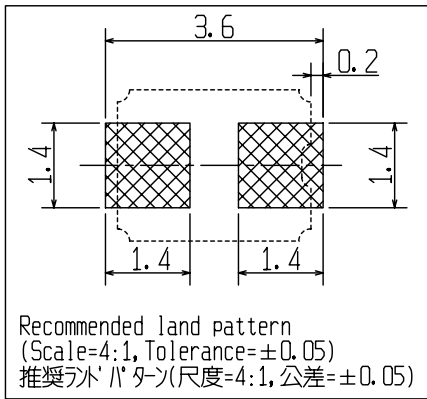
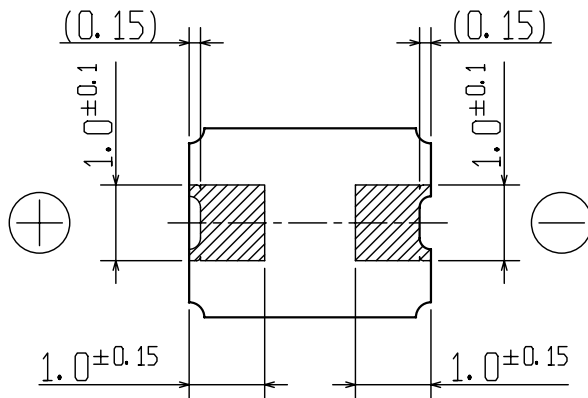
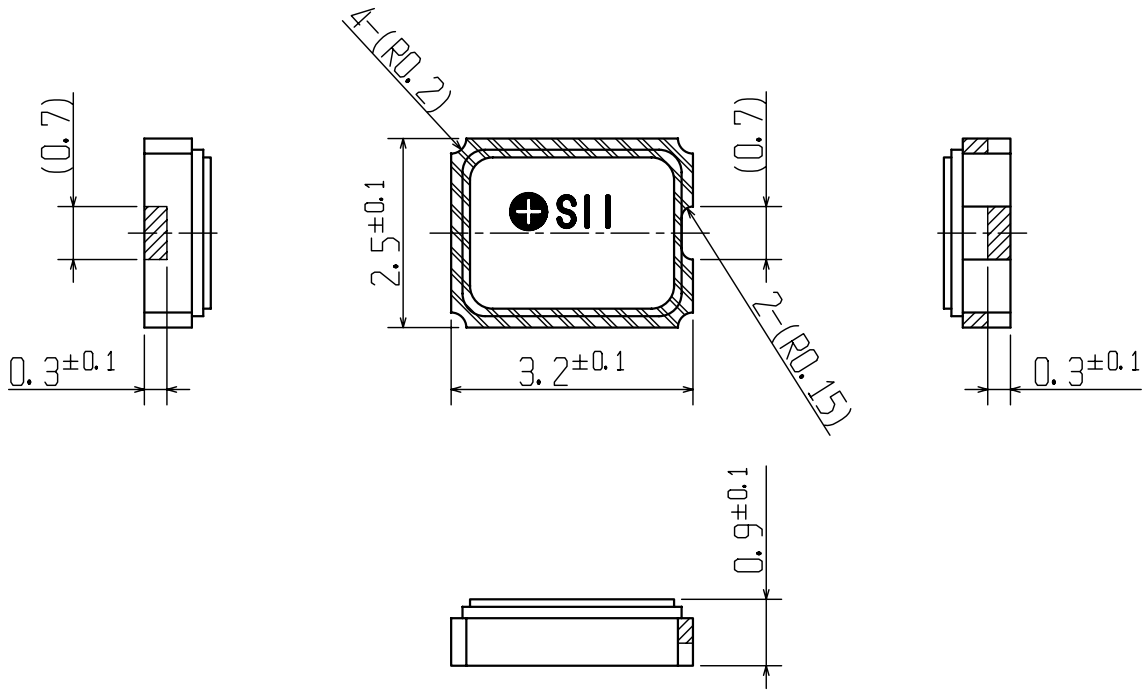

Tolerances of linear dimensions 長さ寸法公差		
Dimension 寸法		Tolerance 公差
0 - 3		±0.20
3 - 6		±0.20
6 - 30		±0.50
Tolerances of angular dimensions 角度寸法公差		
±2°		

				File No. 文件番号	3048CPHO-3225A-2
				Material 材料	
				Process 处理	: Au-Ni-W film : Au-Ni film Au-Ni-W 膜 Au-Ni 膜
E09B-028	Oct. 01, 2009	フラシマ位置変更		Date 日付	Mar. 05, 2009
E09A-005	Mar. 05, 2009	設定		Name 名称	Capacitor drawing
History 履歴	Date 日付	Reason 理由		Name 名称	キャパシタ図面
Approved 承認	Checked 検査	Drawn 製図	Scale 尺度	Cal. No. 製品番号	CPH3225A
冨塚		尾形	Unit 単位	10:1	Drw. No. 図面番号
				1=1mm	
			Rev. 改訂	2	CPH 3225A

Reflow Profile

< Reflow Soldering Conditions >

Reflow Soldering Profile: As per shown in Fig.-1.

The times of repeated reflow soldering must be **two times or less**.

The temperature must be measured at top of the cell.

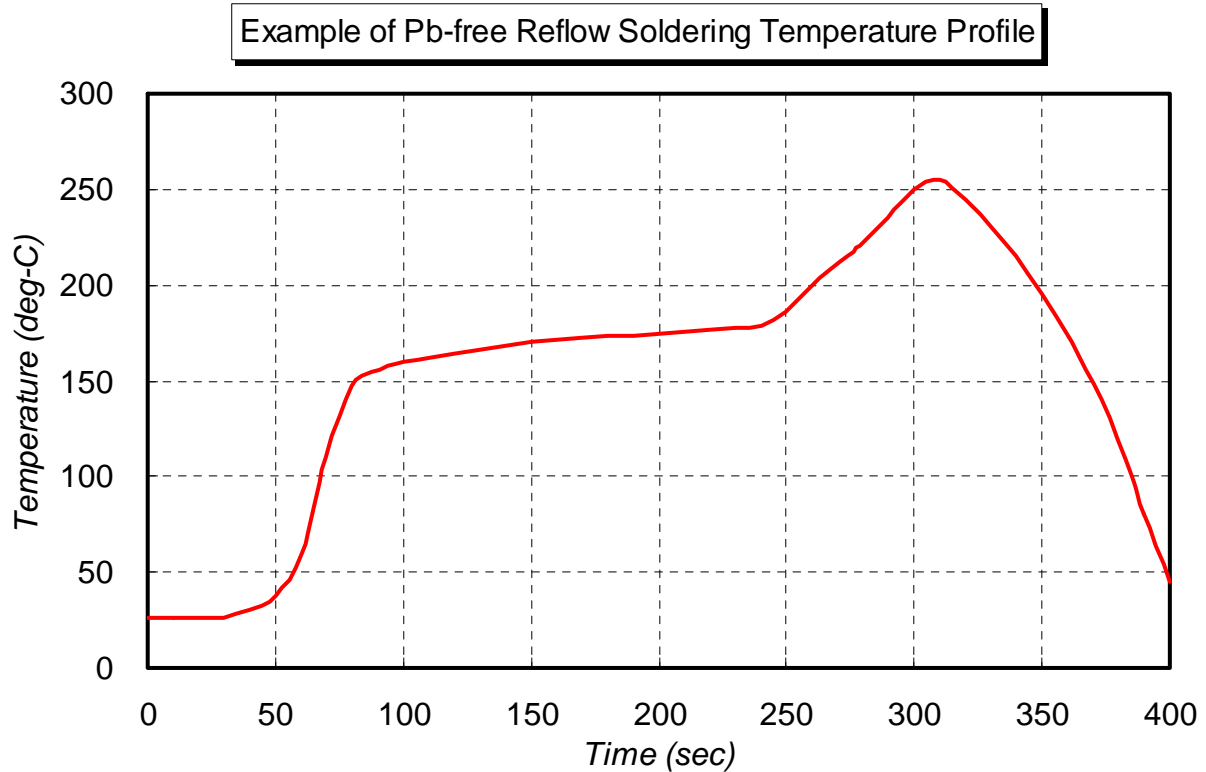

Fig.-1: Reflow soldering profile (for reference only)

*1: Time above 217°C must be max. 80seconds.

Time above 250°C must be max. 20seconds.

Peak temperature must be max. 260°C.

< Underfilling Conditions >

Temperature: Max.160°C, Time: Max.10 minutes.

- (Notes) 1. All fillets not specified : R max 0.3
 2. The plan dimension : the bottom of emboss pocket
 3. Accumulation tolerance of holes: 40±0.2mm(10 holes)
 注) 1. 指示のないコーナーは R0.3 以下のこと
 2. 平面図における寸法はエンボスポケット底での寸法である
 3. 送り丸穴累積公差は、10ピッチで40±0.2mmとする。

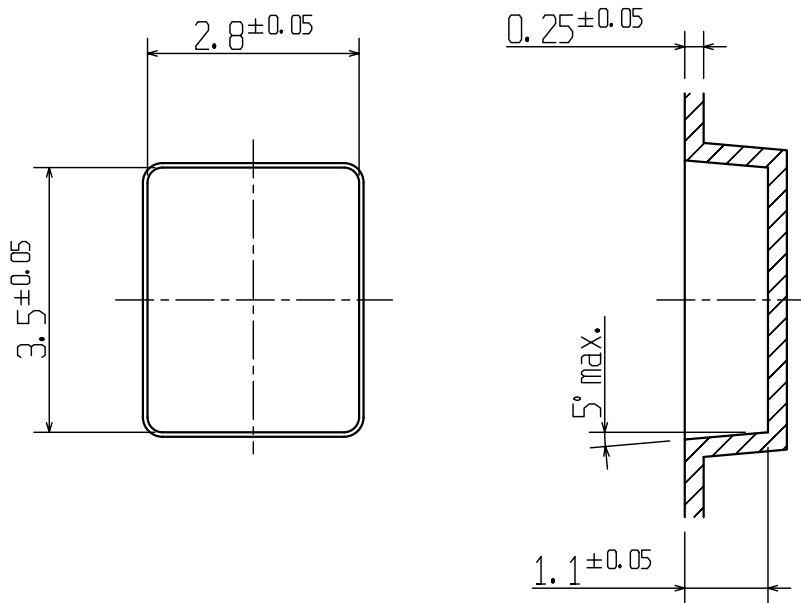
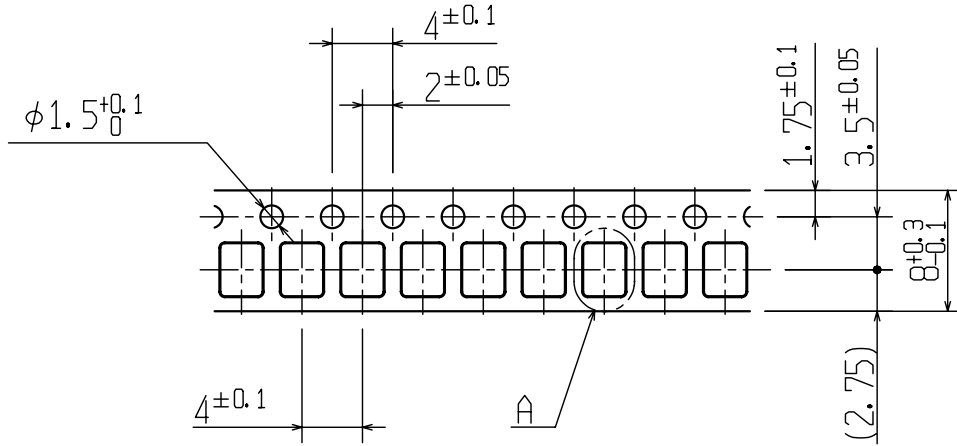

Detail A (10:1)
 詳細 A (10:1)

Tolerances of linear dimensions 長さ寸法公差		
Dimension 寸法		Tolerance 公差
0 - 3		±0.20
3 - 6		±0.20
6 - 30		±0.50
Tolerances of angular dimensions 角度寸法公差		
±2°		

				File No. ファイル番号	3177E290-00000-4
				Material 材料	Conductive polystyren 導電性ポリスチレン
E08B-018	Jul. 07, 2008	センターホール削除, テープ幅公差変更		Process 処理	217, 500 P/巻 (3/4 行ル巻)
E08B-017	Jun. 26, 2008	テープ幅, テープ厚み変更			
E07B-039	Nov. 09, 2007	社名変更, 製品番号変更		Date 日付	Jul. 09, 2007
E07A-036	Jul. 19, 2007	設定		Name 名称	Drawing of emboss carrier tape エンボスキャリアテープ図面
History 履歴	Date 日付	Reason 理由			
Approved 承認	Checked 検査	Drawn 製図	Scale 尺度	2:1	Cal. No. 製品番号
冨塚		尾形	Unit 単位	1=1mm	
			Rev. 改訂	4	Drw. No. 図面番号

Capacitor position in emboss tape

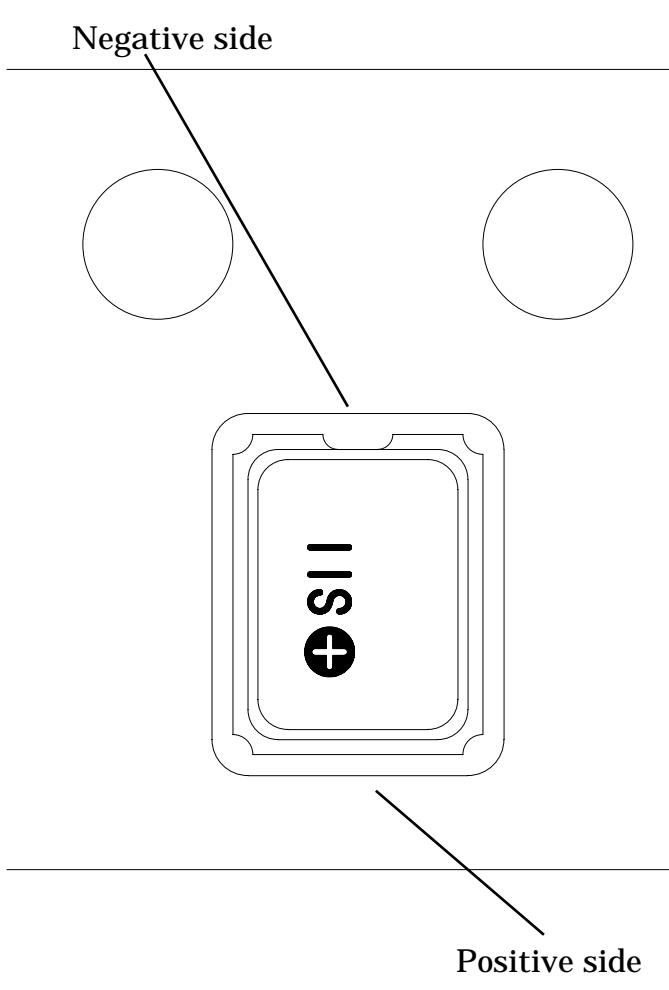
1. Model
CPH3225A
2. Capacitor position in emboss tape
 <p>Negative side</p> <p>Positive side</p>
3. Quantity / reel
MAX. 10,000 pcs / reel

(Notes) There is no part lack in the component section.
 (注) 製品部分には、部品欠落の無いこと

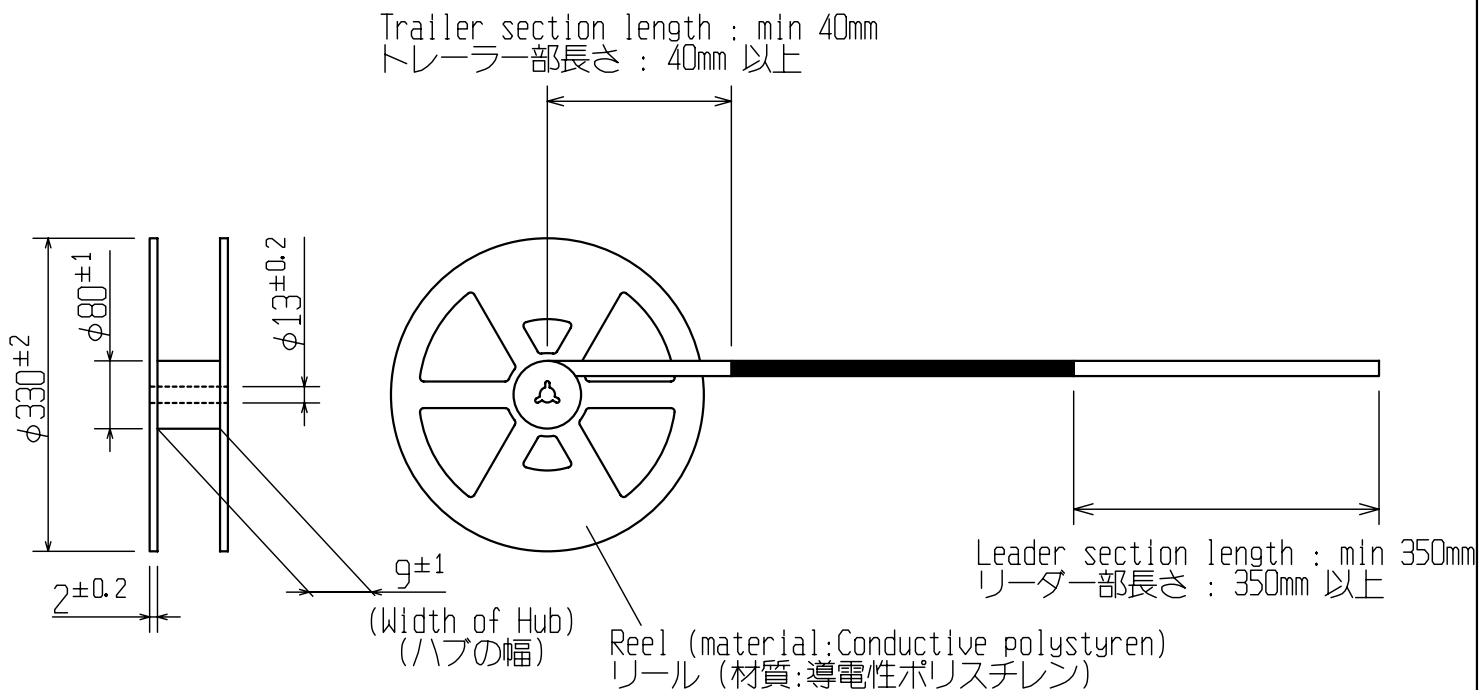

Carrier tape
 (material: Conductive polystyrene)
 キャリアテープ
 (材質: 導電性ポリスチレン)

Drawing direction
 引き出し方向

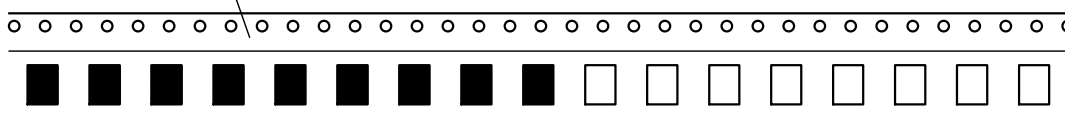

Component section
 製品部分

Empty Carrier tape sealed
 with top cover tape
 (material: PET) : min 350mm
 カバーテープ(材質: PET)
 シール付き空ポケット部長さ : 350mm以上
 Top cover tape non-peeling strength
 : 0.1~0.7N
 カバーテープ剥離強度 : 0.1~0.7N

Leader section length : min 350mm
 リーダー部長さ : 350mm 以上

				Fail No. 汎用番号	3177SE08-00000-1
				Date 日付	Aug. 08, 2008
E08A-026	Aug. 08, 2008	設定		Name 名称	Taping specifications テープニング仕様
History 履歴	Date 日付	Reason 理由			
Approved 承認	Checked 検査	Drawn 製図	Scale 尺度	Cal. No. 製品番号	
冨塚		尾形	Unit 単位	1=1mm	Drw. No. 図面番号
			Rev. 改訂	1	

Drawing direction
引出し方向

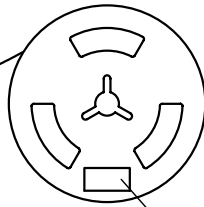

Label: Model, quantity
ラベル: 製品名, 数量

Emboss tape reel
テープリール

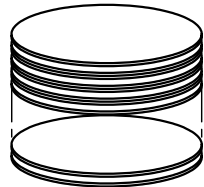

Max 8reels

Max8reels in plastic bag packing
最大8巻ビニール袋梱包

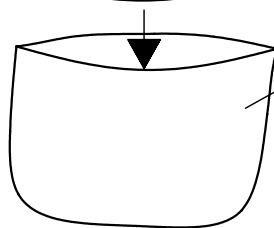

Plastic bag
ビニール袋

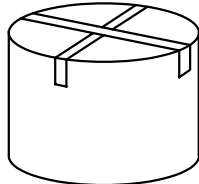

Outer packing
外箱梱包

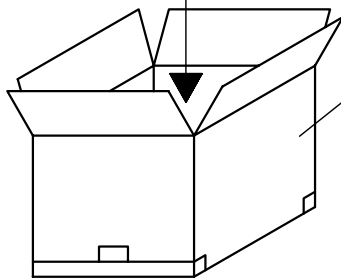

Large hard carton
段ボール箱

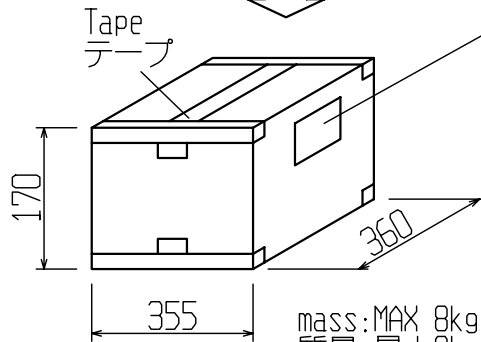

Tape
テープ

Label: Model, quantity, delivery date,
purchase order number etc.
ラベル: 製品名, 納入数量, 納入月日
注番 等

Package appearance
梱包外観

mass: MAX 8kg
質量: 最大8kg

The above packaging specifications are standard.
These specifications vary with the quantity to be supplied.
上記、梱包形態は標準的なもので、納入時の数量により異なります。

E10B-003	Jan. 21, 2010	テープ表記変更	File No. ファイル番号	317700A8-00000-3
E08B-019	Aug. 20, 2008	最大梱包数量の変更(5巻→8巻), 最大質量変更(10kg→8kg)	Date 日付	Aug. 08, 2008
E08A-026	Aug. 08, 2008	設定	Name 名称	Package specifications
History履歴	Date 日付	Reason 理由		梱包仕様
Approved 承認	Checked 検査	Drawn 製図	Scale 尺度	
篠田	/	尾形	Unit 単位	1=1mm
			Rev. 改訂	3
			Cal. No. 製品番号	A8
			Drw. No. 図面番号	3177 00A8

Precautions for Your Safety

**SII capacitors (XC, XH, CP, SC) contain flammable organic solvents.
For your safety, please follow following prohibitions.**



WARNING!

- 1. Do not charge by high current or high voltage.**
Doing so may generate gas inside the capacitor, resulting, swelling, catching fire, heat generation or bursting.
- 2. Do not reverse placement of (+) and (-)**
SII capacitors have polarity. If the (+) and (-) side of the capacitor is reverse inserted, it may cause a short-circuiting or over discharge of the capacitor on some equipment and it may induce overheating, explosion or fire.
- 3. Do not solder directly to the capacitor**
If soldering is performed directly to the capacitor, the capacitor is heated up, consequently cause leakage, explosion or fire due to overheating from internal short-circuiting.
- 4. Keep capacitors out of children's reach.**
If leaked liquid is ingested or a capacitor is swallowed, consult a physician immediately.
- 5. Do not heat, disassemble nor dispose of in fire**
Doing so damages the insulation materials and may cause catching fire, heat generation, leakage or bursting.
- 6. Do not discharge by force**
If the capacitor is discharged by direct connection to an external power supply etc., voltage of the capacitor will decline lower than 0 volts (electrical reversal) and will cause the capacitor case to expand, overheat, leak, explode or burn.
- 7. In case of leakage or a strange-smell; keep away from fire to prevent ignition of any leaked electrolyte.**



CAUTION!

- 1. If leaked liquids gets in the eyes, wash them with clean water, and consult a physician immediately.**
- 2. Do not use nor leave the capacitors neither in direct sunlight nor in high-temperature areas.**
It may cause catching fire, heat generation, leakage or bursting.
- 3. Do not use new and used capacitors together.**
Do not use different types of capacitors together.
- 4. If you connect two or more capacitors in series or parallel, please consult us in advance.**
It may cause bursting or catching fire due to unbalanced load or voltage.
- 5. Keep capacitors away from direct sunlight, high temperature and humidity.**
It may cause heat generation or performance deterioration.

For prevention quality trouble in capacitor

- 1. Do not conduct reflow soldering after charging the capacitor.**
The deterioration of the capacitor shall be caused. In serious case, the capacitor may start swell and explode or leakage.
- 2. Pay attention to soldering by tips**
Do not touch the capacitor by solder chips, in case of soldering another components after equipping capacitor. In basically, keep any high temperature process away from capacitor. (Except for reflow soldering and underfilling)
- 3. Pay attention to the operating temperature.**
The ambient temperature greatly affects the lifetime of the capacitor.
By reducing the temperature by 10deg.-C, the lifetime can be approximately doubled.
- 4. Do not welding the tab to the capacitor.**
The tab welding by inappropriate conditions will lead to damage or breakage of the capacitor. In serious case, the capacitor may start swell and leakage or catch fire and explode. If needs capacitor with tabs, please consult us.
- 5. Pay attention to washing and drying.**
Some detergent or high temperature drying cause deteriorates of capacitor. If you need to wash capacitors, consult us.

Disposal

Disposal

Recent environmental protection concerns have increased globally and waste and recycling are regulated in the world. The current regulations differ in each country, state and local municipality. Please consult local regulations and authorities for recommended disposal of batteries. If you are in question of application or safety of our batteries, please consult your local authorities.