

## Evaluation platform based on the BlueNRG-M2SA module

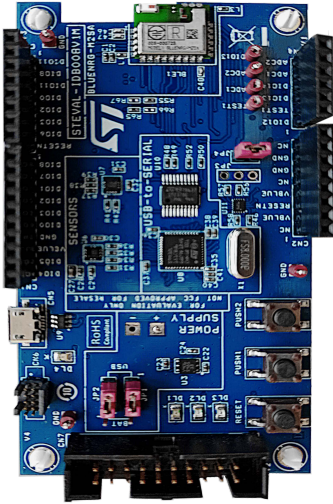

### Features

- Bluetooth LE evaluation board embedding the BlueNRG-M2SA certified module based on the BlueNRG-2 Bluetooth low energy system-on-chip
- Associated BlueNRG-2 development kit software package (STSW-BLUENRG1-DK)
- Up to +5 dBm available output power
- Bluetooth low energy v5.0 compliant, supports master, slave and simultaneous master-and-slave roles
- Integrated balun with matching network and harmonics filter
- Three user LEDs and two user buttons
- 3D digital accelerometer and 3D digital gyroscope
- MEMS pressure sensor with embedded temperature sensor
- Battery holder
- JTAG debug connector
- USB to serial bridge for I/O channel with the BlueNRG-2 device
- Jumper to measure BlueNRG-M2SA current
- RoHS and WEEE compliant

### Description

The STEVAL-IDB008V1M evaluation platform is based on the Bluetooth v5.0 compliant BlueNRG-M2SA module with embedded BlueNRG-2 low power Bluetooth LE SoC, able to function as a master or slave, or in a simultaneous master and slave role.

The STEVAL-IDB008V1M provides a set of hardware resources for a wide range of application scenarios: sensor data (accelerometer, pressure and temperature sensors), remote control (buttons and LEDs) and debug message management via USB virtual COM.

Three power options are available (USB only, battery only and external power supply plus USB) for application development and testing flexibility.

Product summary	
Evaluation platform based on the BlueNRG-M2SA module	STEVAL-IDB008V1M
Very low power application processor module for Bluetooth low energy v5.0	BlueNRG-M2SA
Bluetooth low energy wireless system-on-chip	BlueNRG-2
Applications	Factory Automation Industrial Tools Wireless Connectivity

# 1 Schematic diagrams

Figure 1. STEVAL-IBD008V1M circuit schematic (1 of 3)

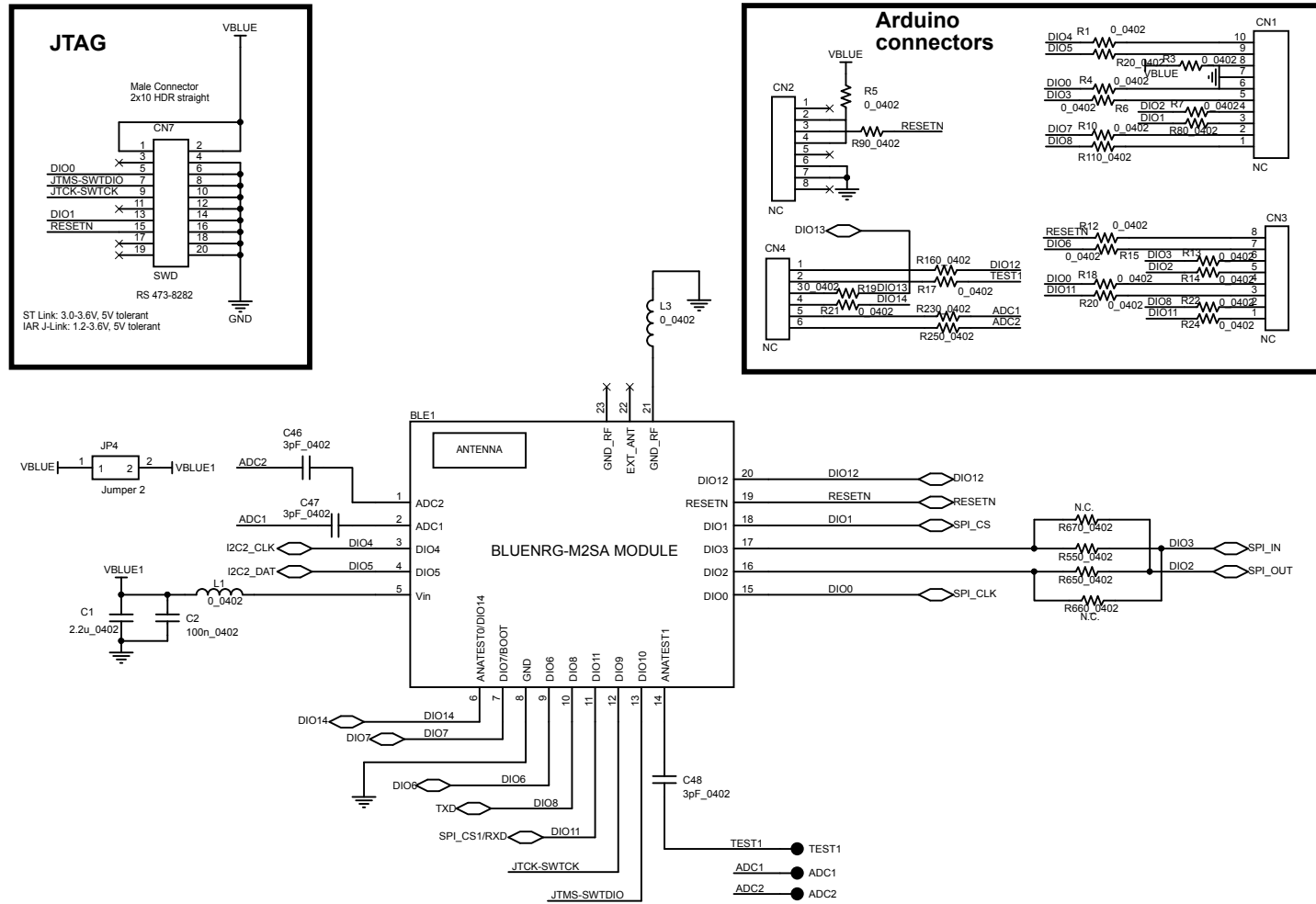

Figure 2. STEVAL-IBD008V1M circuit schematic (2 of 3)

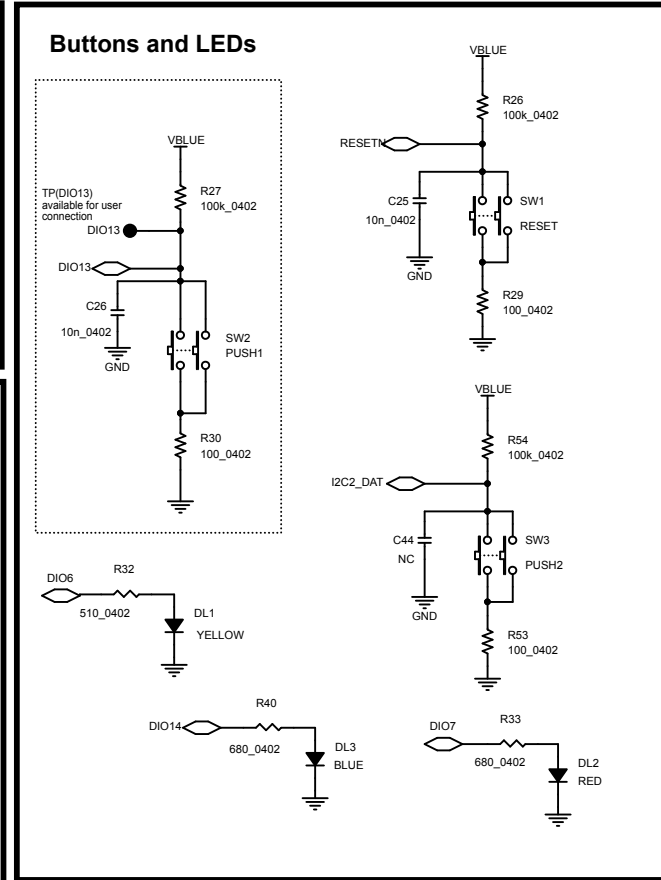
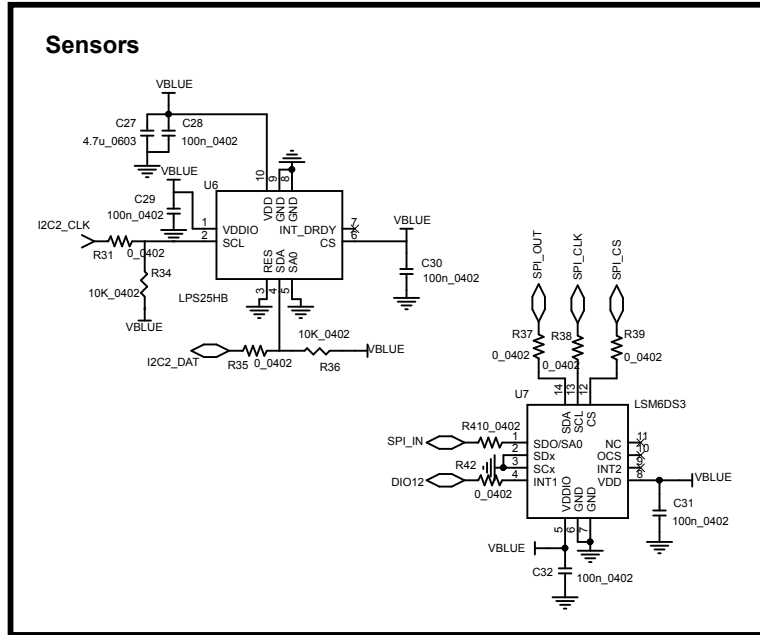
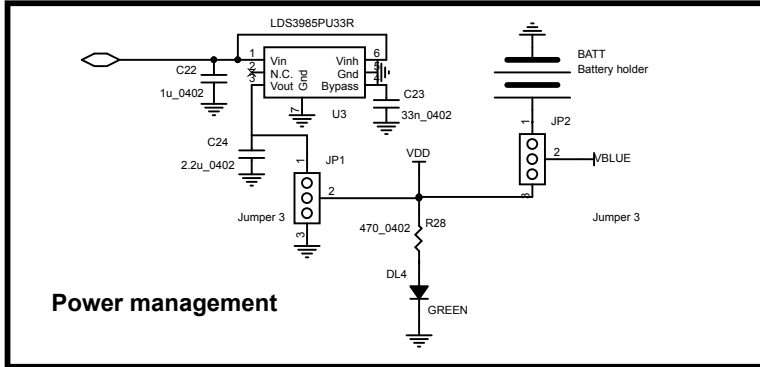
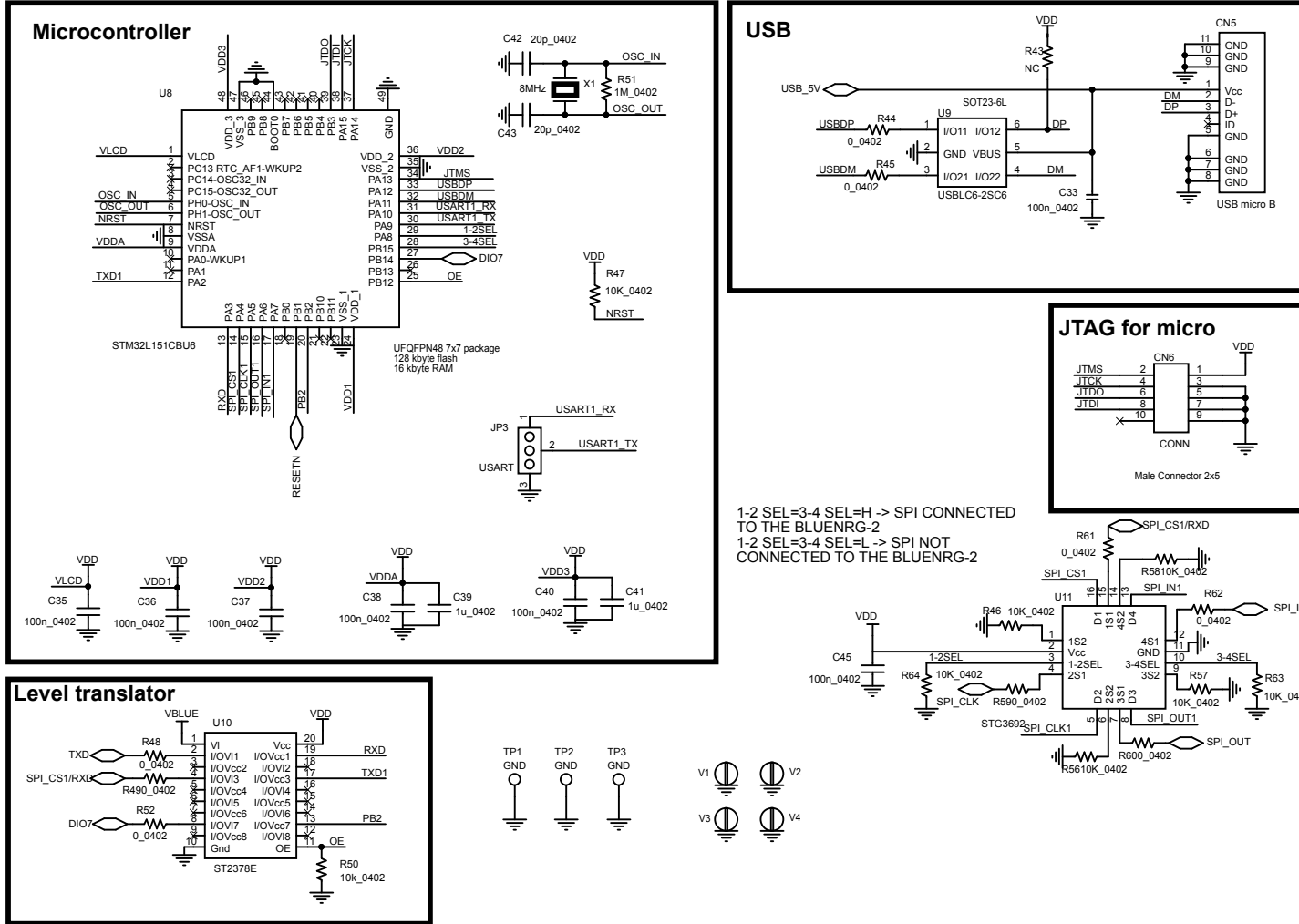

Figure 3. STEVAL-IBD008V1M circuit schematic (3 of 3)



## Revision history

**Table 1. Document revision history**

Date	Version	Changes
08-May-2020	1	Initial release.
20-May-2020	2	Updated cover page image. Minor text changes.

**IMPORTANT NOTICE – PLEASE READ CAREFULLY**

STMicroelectronics NV and its subsidiaries (“ST”) reserve the right to make changes, corrections, enhancements, modifications, and improvements to ST products and/or to this document at any time without notice. Purchasers should obtain the latest relevant information on ST products before placing orders. ST products are sold pursuant to ST’s terms and conditions of sale in place at the time of order acknowledgement.

Purchasers are solely responsible for the choice, selection, and use of ST products and ST assumes no liability for application assistance or the design of Purchasers’ products.

No license, express or implied, to any intellectual property right is granted by ST herein.

Resale of ST products with provisions different from the information set forth herein shall void any warranty granted by ST for such product.

ST and the ST logo are trademarks of ST. For additional information about ST trademarks, please refer to [www.st.com/trademarks](http://www.st.com/trademarks). All other product or service names are the property of their respective owners.

Information in this document supersedes and replaces information previously supplied in any prior versions of this document.

© 2020 STMicroelectronics – All rights reserved