

# QUINT4-PS/1AC/24DC/10/CO - Power supply unit



2904625

<https://www.phoenixcontact.com/us/products/2904625>

Please be informed that the data shown in this PDF document is generated from our online catalog. Please find the complete data in the user documentation. Our general terms of use for downloads are valid.



Primary-switched QUINT POWER power supply with free choice of output characteristic curve, SFB (selective fuse breaking) technology, NFC interface, and protective coating, input: 1-phase, output: 24 V DC / 10 A

## Product description

The fourth generation of the high-performance QUINT POWER power supplies ensures superior system availability by means of new functions. Signaling thresholds and characteristic curves can be individually adjusted via the NFC interface. The unique SFB technology and preventive function monitoring of the QUINT POWER power supply increase the availability of your application.

## Commercial data

Item number	2904625
Packing unit	1 pc
Minimum order quantity	1 pc
Sales key	CM10
Product key	CMPI13
GTIN	4055626939223
Weight per piece (including packing)	1,132.5 g
Weight per piece (excluding packing)	869 g
Customs tariff number	85044095
Country of origin	TH

# QUINT4-PS/1AC/24DC/10/CO - Power supply unit



2904625

<https://www.phoenixcontact.com/us/products/2904625>

## Technical data

### Input data

Control input (configurable) Rem	Output power ON/OFF (SLEEP MODE)
Default	Output power ON (>40 k $\Omega$ /24 V DC/open bridge between Rem and SGnd)

### AC operation

Network type	Star network
Nominal input voltage range	100 V AC ... 240 V AC
Input voltage range	100 V AC ... 240 V AC -15 % ... +10 %
Derating	< 100 V AC (1 %/V)
Electric strength, max.	300 V AC 60 s
Typical national grid voltage	120 V AC 230 V AC
Voltage type of supply voltage	AC/DC
Inrush current	typ. 12 A (at 25 °C)
Inrush current integral ( $I^2t$ )	< 0.7 A <sup>2</sup> s
Inrush current limitation	12 A (after 1 ms)
AC frequency range	50 Hz ... 60 Hz -10 % ... +10 %
Frequency range ( $f_N$ )	50 Hz ... 60 Hz -10 % ... +10 % 16.7 Hz (acc. to EN 50163)
Mains buffering time	typ. 42 ms (120 V AC) typ. 44 ms (230 V AC)
Current consumption	3.4 A (100 V AC) 2.8 A (120 V AC) 1.5 A (230 V AC) 1.5 A (240 V AC)
Nominal power consumption	274 VA
Protective circuit	Transient surge protection; Varistor, gas-filled surge arrester
Power factor (cos phi)	0.94
Switch-on time	< 1 s
Typical response time	300 ms (from SLEEP MODE)
Input fuse	8 A (slow-blow, internal)
Recommended breaker for input protection	10 A ... 16 A (Characteristic B, C, D, K or comparable)
Discharge current to PE	< 3.5 mA 0.7 mA (264 V AC, 60 Hz)

### DC operation

Nominal input voltage range	110 V DC ... 250 V DC
Input voltage range	110 V DC ... 250 V DC -18 % ... +40 %
Derating	< 110 V DC (1 %/V)
Voltage type of supply voltage	DC
Current consumption	3 A (110 V DC)

# QUINT4-PS/1AC/24DC/10/CO - Power supply unit



2904625

<https://www.phoenixcontact.com/us/products/2904625>

	1.3 A (250 V DC)
--	------------------

## Output data

Efficiency	typ. 92.5 % (120 V AC)
	typ. 93.4 % (230 V AC)
Output characteristic	U/I Advanced
	Smart HICCUP
	FUSE MODE
Nominal output voltage	24 V DC
Setting range of the output voltage ( $U_{Set}$ )	24 V DC ... 29.5 V DC (constant capacity)
Nominal output current ( $I_N$ )	10 A
Static Boost ( $I_{Stat.Boost}$ )	12.5 A
Dynamic Boost ( $I_{Dyn.Boost}$ )	20 A (5 s)
Selective Fuse Breaking ( $I_{SFB}$ )	60 A (15 ms)
Magnetic circuit breaker tripping	A1...A6 / B2...B6 / C1...C3 / Z1...Z6
Derating	> 60 °C (2.5 %/K)
Feedback voltage resistance	≤ 35 V DC
Protection against overvoltage at the output (OVP)	≤ 32 V DC
Control deviation	< 0.5 % (Static load change 10 % ... 90 %)
	< 4 % (Dynamic load change 10 % ... 90 %, (10 Hz))
	< 0.25 % (change in input voltage ±10 %)
Residual ripple	< 80 mV <sub>PP</sub> (with nominal values)
Short-circuit-proof	yes
No-load proof	yes
Output power	240 W
	300 W
	480 W
Apparent power	336 VA (120 V, $U_{OUT} = 24$ V, $I_{OUT} = \text{stat. Boost}$ )
	345 VA (230 V, $U_{OUT} = 24$ V, $I_{OUT} = \text{stat. Boost}$ )
Maximum no-load power dissipation	< 3 W (120 V AC)
	< 3 W (230 V AC)
Power loss nominal load max.	< 20 W (120 V AC)
	< 17 W (230 V AC)
Power dissipation SLEEP MODE	< 3 W (120 V AC)
	< 3 W (230 V AC)
Crest factor	typ. 1.50 (120 V AC)
	typ. 1.67 (230 V AC)
Rise time	< 1 s ( $U_{Out} = 10$ % ... 90 %)
Connection in parallel	yes, for redundancy and increased capacity
Connection in series	yes

## Signal

Signal ground SGnd	Reference potential for Out1, Out2, and Rem
--------------------	---

## Signal Out 1 (configurable)

# QUINT4-PS/1AC/24DC/10/CO - Power supply unit



2904625

<https://www.phoenixcontact.com/us/products/2904625>

Digital	24 V DC 20 mA
Default	24 V DC 20 mA 24 V DC for $U_{Out} > 0.9 \times U_{Set}$

## Signal Out 2 (configurable)

Digital	24 V DC 20 mA
Analog	4 mA ... 20 mA $\pm 5\%$ (Load $\leq 400 \Omega$ )
Default	24 V DC 20 mA 24 V DC for $P_{Out} < P_N$

## Signal relay 13/14 (configurable)

Default	closed ( $U_{out} > 0.9 U_{Set}$ )
Digital	24 V DC 1 A
	30 V AC/DC 0.5 A

## Connection data

### Input

Connection method	Screw connection
Conductor cross section, rigid min.	0.2 mm <sup>2</sup>
Conductor cross section, rigid max.	2.5 mm <sup>2</sup>
Conductor cross section flexible min.	0.2 mm <sup>2</sup>
Conductor cross section flexible max.	2.5 mm <sup>2</sup>
Single conductor/flexible terminal point with ferrule with plastic sleeve, min.	0.25 mm <sup>2</sup>
Single conductor/flexible terminal point with ferrule with plastic sleeve, max.	2.5 mm <sup>2</sup>
Single conductor/flexible terminal point with ferrule without plastic sleeve, min.	0.25 mm <sup>2</sup>
Single conductor/flexible terminal point with ferrule without plastic sleeve, max.	2.5 mm <sup>2</sup>
Conductor cross section AWG min.	24
Conductor cross section AWG max.	14
Stripping length	6.5 mm
Tightening torque, min	0.5 Nm
Tightening torque max	0.6 Nm

### Output

Connection method	Screw connection
Conductor cross section, rigid min.	0.2 mm <sup>2</sup>
Conductor cross section, rigid max.	2.5 mm <sup>2</sup>
Conductor cross section flexible min.	0.2 mm <sup>2</sup>
Conductor cross section flexible max.	2.5 mm <sup>2</sup>
Single conductor/flexible terminal point with ferrule with plastic sleeve, min.	0.25 mm <sup>2</sup>
Single conductor/flexible terminal point with ferrule with plastic sleeve, max.	2.5 mm <sup>2</sup>
Single conductor/flexible terminal point with ferrule without plastic sleeve, min.	0.25 mm <sup>2</sup>
Single conductor/flexible terminal point with ferrule without plastic	2.5 mm <sup>2</sup>

# QUINT4-PS/1AC/24DC/10/CO - Power supply unit



2904625

<https://www.phoenixcontact.com/us/products/2904625>

sleeve, max.	
Conductor cross section AWG min.	24
Conductor cross section AWG max.	14
Stripping length	6.5 mm
Tightening torque, min	0.5 Nm
Tightening torque max	0.6 Nm

## Signal

Connection method	Push-in connection
Conductor cross section, rigid min.	0.2 mm <sup>2</sup>
Conductor cross section, rigid max.	1 mm <sup>2</sup>
Conductor cross section flexible min.	0.2 mm <sup>2</sup>
Conductor cross section flexible max.	1.5 mm <sup>2</sup>
Single conductor/flexible terminal point with ferrule with plastic sleeve, min.	0.2 mm <sup>2</sup>
Single conductor/flexible terminal point with ferrule with plastic sleeve, max.	0.75 mm <sup>2</sup>
Single conductor/flexible terminal point with ferrule without plastic sleeve, min.	0.2 mm <sup>2</sup>
Single conductor/flexible terminal point with ferrule without plastic sleeve, max.	1.5 mm <sup>2</sup>
Conductor cross section AWG min.	24
Conductor cross section AWG max.	16
Stripping length	8 mm

## Signaling

Types of signaling	LED
	Floating signal contact
	Active signal output Out1 (digital, configurable)
	Active signal output Out2 (analog, configurable)
	Remote contact
	Signal ground SGnd

## Signal output

P <sub>Out</sub>	> 100 % (LED lights up yellow, output power > 240 W)
	> 75 % (LED lights up green, output power > 180 W)
	> 50 % (LED lights up green, output power > 120 W)
U <sub>Out</sub>	> 0.9 × U <sub>Set</sub> (LED lights up green)
	< 0.9 × U <sub>Set</sub> (LED flashes green)

## Electrical properties

Number of phases	1.00
Insulation voltage input/output	4 kV AC (type test)
	2 kV AC (routine test)
Insulation voltage output / PE	0.5 kV DC (type test)
	0.5 kV DC (routine test)

# QUINT4-PS/1AC/24DC/10/CO - Power supply unit



2904625

<https://www.phoenixcontact.com/us/products/2904625>

Insulation voltage input / PE	3.5 kV AC (type test)
	2.4 kV AC (routine test)
Switching frequency	90.00 kHz ... 110.00 kHz (Auxiliary converter stage)
	50.00 kHz ... 245.00 kHz (Main converter stage)
	35.00 kHz ... 700.00 kHz (PFC stage)

## Product properties

Product type	Power supply
Product family	QUINT POWER
MTBF (IEC 61709, SN 29500)	> 1251000 h (25 °C)
	> 783000 h (40 °C)
	> 377000 h (60 °C)
Environmental protection directive	RoHS Directive 2011/65/EU
	WEEE
	Reach

## Data management status

Article revision	01
------------------	----

## Insulation characteristics

Protection class	I
Degree of pollution	2

## Life expectancy (electrolytic capacitors)

Current	5 A
Temperature	40 °C
Time	286000 h
Additional text	120 V AC

## Life expectancy (electrolytic capacitors)

Current	5 A
Temperature	40 °C
Time	283000 h
Additional text	230 V AC

## Life expectancy (electrolytic capacitors)

Current	10 A
Temperature	25 °C
Time	377000 h
Additional text	120 V AC

## Life expectancy (electrolytic capacitors)

Current	10 A
Temperature	25 °C
Time	454000 h
Additional text	230 V AC

# QUINT4-PS/1AC/24DC/10/CO - Power supply unit



2904625

<https://www.phoenixcontact.com/us/products/2904625>

## Life expectancy (electrolytic capacitors)

Current	10 A
Temperature	40 °C
Time	133000 h
Additional text	120 V AC

## Life expectancy (electrolytic capacitors)

Current	10 A
Temperature	40 °C
Time	160000 h
Additional text	230 V AC

## Dimensions

Dimensional drawing	
Width	50 mm
Height	130 mm
Depth	125 mm

## Installation dimensions

Installation distance right/left	5 mm / 5 mm
Installation distance top/bottom	50 mm / 50 mm

## Alternative assembly

Width	122 mm
Height	130 mm
Depth	53 mm

## Mounting

Mounting type	DIN rail mounting
Assembly note	alignable: $P_N \geq 50\%$ , 5 mm horizontally, 15 mm next to active components, 50 mm vertically alignable: $P_N < 50\%$ , 0 mm horizontally, 40 mm vertically top, 20 mm vertically bottom
Mounting position	horizontal DIN rail NS 35, EN 60715
With protective coating	yes

## Material specifications

Flammability rating according to UL 94 (housing / terminal blocks)	V0
--	----

# QUINT4-PS/1AC/24DC/10/CO - Power supply unit



2904625

<https://www.phoenixcontact.com/us/products/2904625>

Housing material	Metal
Hood version	Stainless steel X6Cr17
Side element version	Aluminum

## Environmental and real-life conditions

### Ambient conditions

Degree of protection	IP20
Ambient temperature (operation)	-25 °C ... 70 °C (> 60 °C Derating: 2,5 %/K)
Ambient temperature (storage/transport)	-40 °C ... 85 °C
Ambient temperature (start-up type tested)	-40 °C
Maximum altitude	≤ 5000 m (> 2000 m, observe derating)
Climatic class	3K3 (in acc. with EN 60721)
Max. permissible relative humidity (operation)	≤ 100 % (at 25 °C, non-condensing)
Shock	18 ms, 30g, in each space direction (according to IEC 60068-2-27)
Vibration (operation)	5 Hz ... 100 Hz resonance search 2.3g, 90 min., resonance frequency 2.3g, 90 min. (according to DNV GL Class C)

## Standards and regulations

Rail applications	EN 50121-3-2
	EN 50121-4
	EN 50121-5
	EN 50163
	IEC 62236-3-2
	IEC 62236-4
	IEC 62236-5
	EN 50155
	EN 45545-2 (HL3)
EN 61373 (Class 1B)	
HART FSK Physical Layer Test Specification Compliance	Output voltage $U_{Out}$ compliant
Standard – Limitation of mains harmonic currents	EN 61000-3-2
Standard - Electrical safety	IEC 61010-2-201 (SELV)
Standard – Safety extra-low voltage	IEC 61010-1 (SELV)
	IEC 61010-2-201 (PELV)
Standard - Safe isolation	IEC 61558-2-16
	IEC 61010-2-201
Standard - safety for equipment for measurement, control, and laboratory use	IEC 61010-1
Standard - Safety of transformers	EN 61558-2-16
Battery charging	DIN 41773-1
Approval - requirement of the semiconductor industry with regard to mains voltage dips	SEMI F47-0706, EN 61000-4-11

### Overvoltage category

EN 61010-1	II (≤ 5000 m)
------------	---------------



# QUINT4-PS/1AC/24DC/10/CO - Power supply unit



2904625

<https://www.phoenixcontact.com/us/products/2904625>

EN 62477-1	III ( $\leq 2000$ m)
Fire protection in rail vehicles	
Standard designation	Fire protection in rail vehicles
Standards/specifications	EN 45545-2 (HL3)

## Approvals

CSA	CAN/CSA-C22.2 No. 60950-1-07
	CSA-C22.2 No. 107.1-01
Shipbuilding approval	DNV GL, PRS, BV, LR, ABS
SIQ	BG (type approved)
	CB-Scheme (IEC 61010-1, IEC 61010-2-201, IEC 60950-1)
UL approvals	UL Listed UL 508
	UL/C-UL Recognized UL 60950-1
	UL ANSI/ISA-12.12.01 Class I, Division 2, Groups A, B, C, D (Hazardous Location)

## EMC data

Electromagnetic compatibility	Conformance with EMC Directive 2014/30/EU
Low Voltage Directive	Conformance with Low Voltage Directive 2014/35/EC
EMC requirements for noise emission	EN 61000-6-3
	EN 61000-6-4
EMC requirements for noise immunity	EN 61000-6-1
	EN 61000-6-2
EMC requirements for power supply	IEC 61850-3 (G,H)
	EN 61000-6-5 (switching devices)
Conducted noise emission	EN 55016
	EN 61000-6-3 (Class B)
Noise emission	Additional basic standard EN 61000-6-5 (immunity in power station), IEC/EN 61850-3 (energy supply)
Noise emission	EN 55016
	EN 61000-6-3 (Class B)
DNV GL conducted interference	Class A
Additional text	Area power distribution
DNV GL noise radiation	Class B
Additional text	Bridge and deck area

## Harmonic currents

Standards/regulations	EN 61000-3-2
	EN 61000-3-2 (Class A)
Frequency range	0 kHz ... 2 kHz

## Flicker

Standards/regulations	EN 61000-3-3
	EN 61000-3-3
Frequency range	0 kHz ... 2 kHz

# QUINT4-PS/1AC/24DC/10/CO - Power supply unit



2904625

<https://www.phoenixcontact.com/us/products/2904625>

## Electrostatic discharge

Standards/regulations	EN 61000-4-2
-----------------------	--------------

## Electrostatic discharge

Contact discharge	8 kV (Test Level 4)
Discharge in air	15 kV (Test Level 4)
Comments	Criterion A

## Electromagnetic HF field

Standards/regulations	EN 61000-4-3
-----------------------	--------------

## Electromagnetic HF field

Frequency range	80 MHz ... 1 GHz
Test field strength	20 V/m (Test Level 3)
Frequency range	1 GHz ... 6 GHz
Test field strength	10 V/m (Test Level 3)
Comments	Criterion A

## Fast transients (burst)

Standards/regulations	EN 61000-4-4
-----------------------	--------------

## Fast transients (burst)

Input	4 kV (Test Level 4 - asymmetrical)
Output	4 kV (Test Level 4 - asymmetrical)
Signal	4 kV (Test Level 4 - asymmetrical)
Comments	Criterion A

## Surge voltage load (surge)

Standards/regulations	EN 61000-4-5
-----------------------	--------------

## Surge voltage load (surge)

Input	typ. 3 kV (Test Level 4 - symmetrical)
	typ. 6 kV (Test Level 4 - asymmetrical)
Output	1 kV (Test Level 3 - symmetrical)
	2 kV (Test Level 3 - asymmetrical)
Signal	4 kV (Test Level 4 - asymmetrical)
Comments	Criterion A

## Conducted interference

Standards/regulations	EN 61000-4-6
-----------------------	--------------

## Conducted interference

I/O/S	asymmetrical
Frequency range	0.15 MHz ... 80 MHz
Comments	Criterion A
Voltage	10 V (Test Level 3)

## Power frequency magnetic field

# QUINT4-PS/1AC/24DC/10/CO - Power supply unit



2904625

<https://www.phoenixcontact.com/us/products/2904625>

Standards/regulations	EN 61000-4-8
Frequency	16.7 Hz
	50 Hz
	60 Hz
Test field strength	100 A/m
Additional text	60 s
Comments	Criterion A
Frequency	50 Hz
	60 Hz
Frequency range	50 Hz ... 60 Hz
Test field strength	1 kA/m
Additional text	3 s
Frequency	0 Hz
Test field strength	300 A/m
Additional text	DC, 60 s

## Voltage dips

Standards/regulations	EN 61000-4-11
Voltage	230 V AC
Frequency	50 Hz
Voltage dip	70 %
Number of periods	0.5 / 1 / 25 / 30 periods
Additional text	Test Level 2
Comments	Criterion A: 0.5 / 1 / 25 / 30 periods
Voltage dip	40 %
Number of periods	5 / 10 / 50 periods
Additional text	Test Level 2
Comments	Criterion A
Voltage dip	0 %
Number of periods	0,5 / 1 / 5 / 50 / 250 periods
Additional text	Test Level 2
Comments	Criterion A: 0.5 / 1 period Criterion B: 5 / 50 / 250 periods

## Pulse-shape magnetic field

Standards/regulations	EN 61000-4-9
Test field strength	1000 A/m
Comments	Criterion A

## Attenuated sinusoidal oscillations (ring wave)

Standards/regulations	EN 61000-4-12
Input	2 kV (Test Level 4 - symmetrical)
	4 kV (Test Level 4 - asymmetrical)
Comments	Criterion A

## Asymmetrical conducted disturbance variables

# QUINT4-PS/1AC/24DC/10/CO - Power supply unit



2904625

<https://www.phoenixcontact.com/us/products/2904625>

Standards/regulations	EN 61000-4-16
Test level 1	15 Hz 150 Hz (Test Level 4)
Voltage	30 V 3 V
Test level 2	150 Hz 1.5 kHz (Test Level 4)
Voltage	3 V
Test level 3	1.5 kHz 15 kHz (Test Level 4)
Voltage	3 V 30 V
Test level 4	15 kHz 150 kHz (Test Level 4)
Voltage	30 V
Test level 5	16.7 Hz 50 Hz 60 Hz (Test Level 4)
Voltage	30 V (5 s)
Test level 6	16.7 Hz 50 Hz 60 Hz (Test Level 4)
Voltage	300 V (1 s)
Comments	Criterion A

## Attenuated oscillating wave

Standards/regulations	EN 61000-4-18
Input, output (test level 1)	100 kHz 1 MHz (Test Level 3 - symmetrical)
Voltage	1 kV
Input, output (test level 2)	100 kHz 1 MHz (Test Level 3 - asymmetrical)
Voltage	2.5 kV
Input, output (test level 3)	Test Level 3 - asymmetrical
Signals (test level 1)	100 kHz 1 MHz (Test Level 3 - symmetrical)
Voltage	1 kV
Signals (test level 2)	100 kHz 1 MHz (Test Level 3 - asymmetrical)
Voltage	2.5 kV
Comments	Criterion A

## Attenuated oscillating magnetic field

Standards/regulations	EN 61000-4-10
Test field strength	100 A/m
Test level 1	100 kHz
Test field strength	100 A/m
Test level 2	1 MHz
Comments	Criterion A

## Criteria

Criterion A	Normal operating behavior within the specified limits.
Criterion B	Temporary impairment to operational behavior that is corrected by the device itself.
Criterion C	Temporary adverse effects on the operating behavior, which the device corrects automatically or which can be restored by actuating the operating elements.

# QUINT4-PS/1AC/24DC/10/CO - Power supply unit



2904625

<https://www.phoenixcontact.com/us/products/2904625>

## Drawings

Block diagram

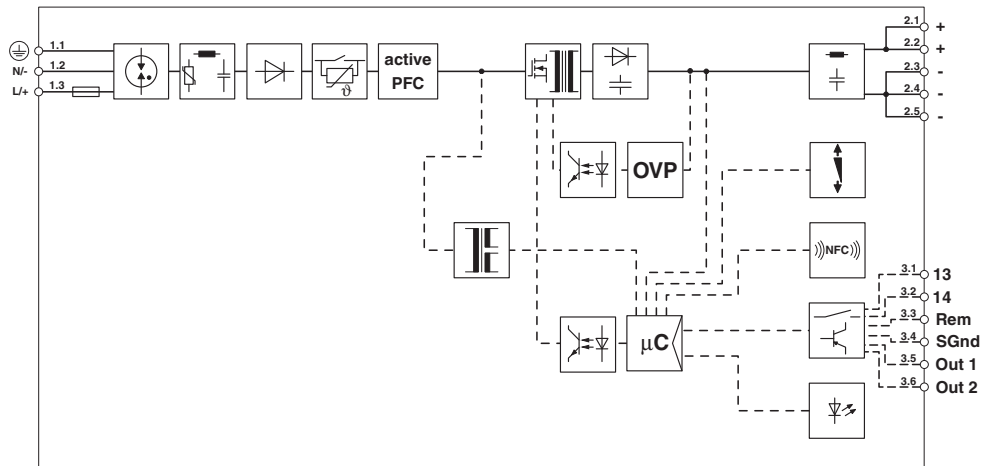

# QUINT4-PS/1AC/24DC/10/CO - Power supply unit

2904625

<https://www.phoenixcontact.com/us/products/2904625>



Dimensional drawing

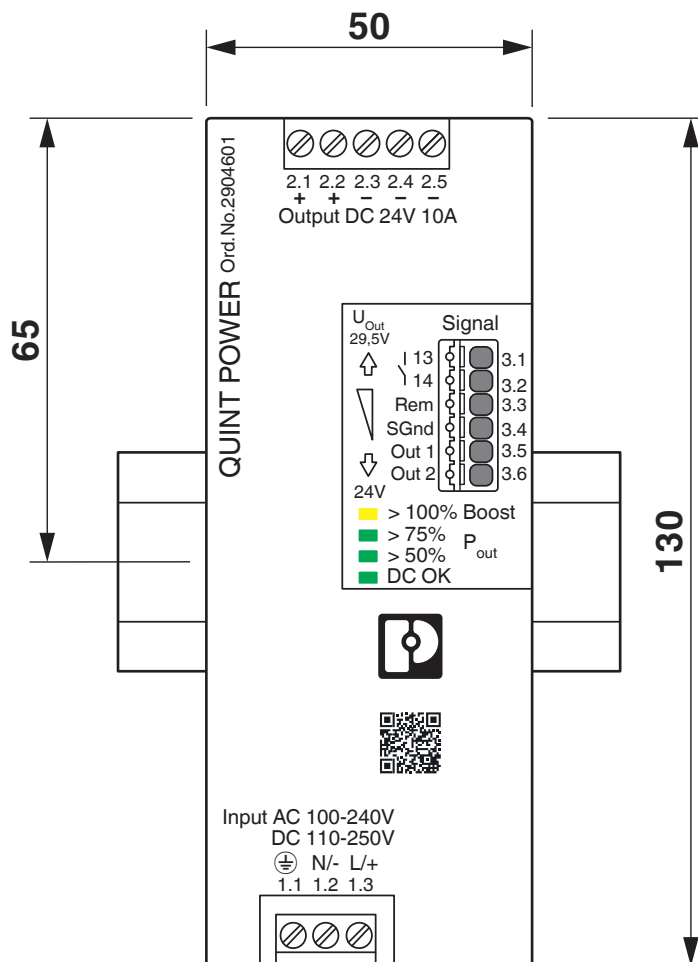

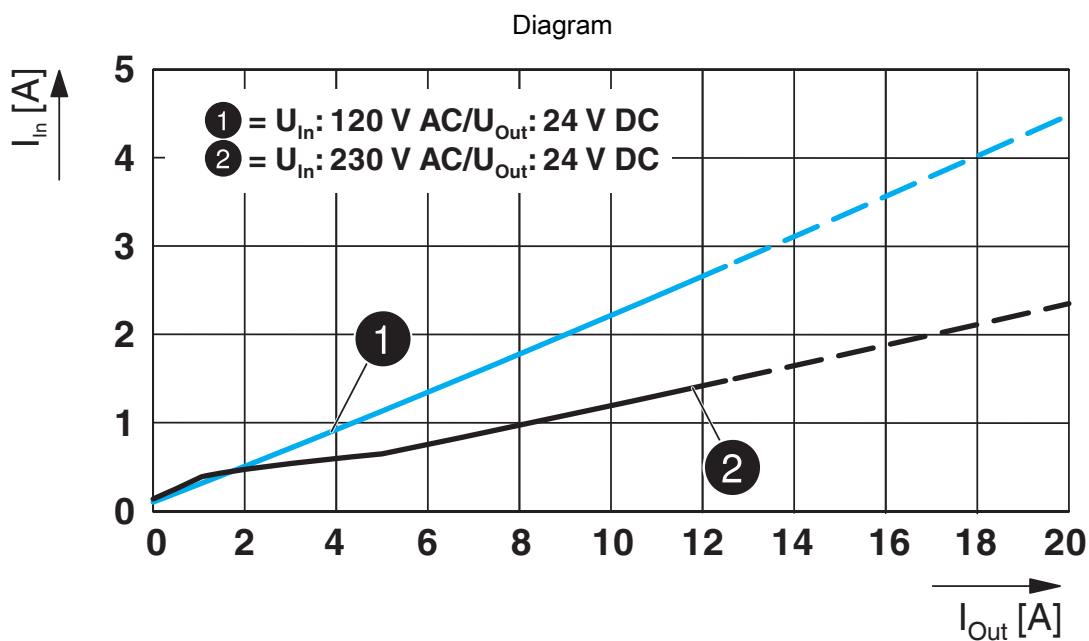
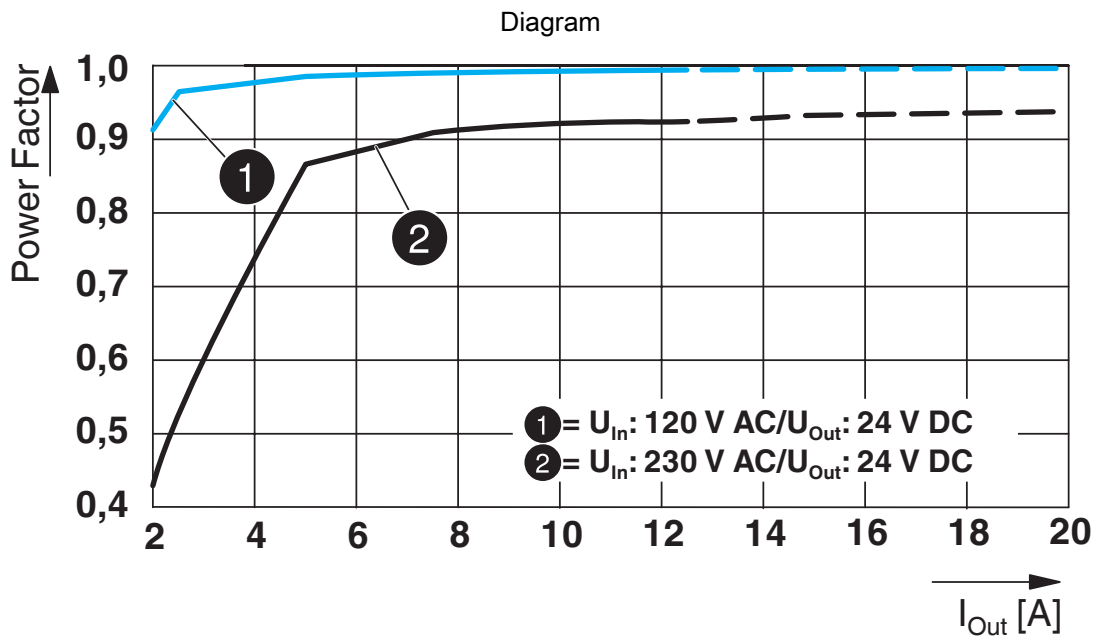

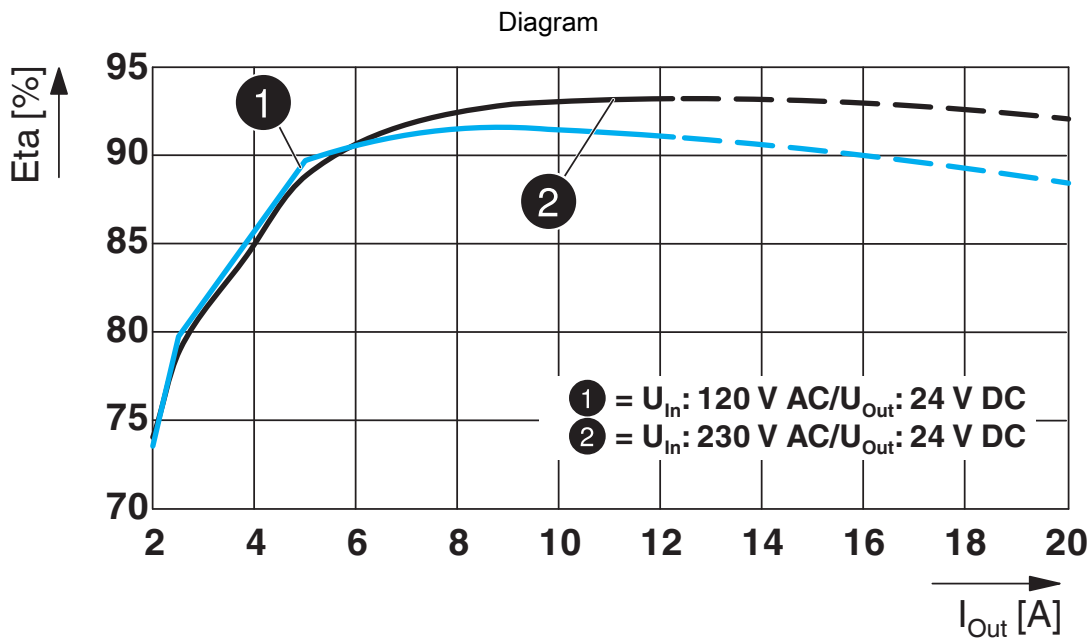

Dimensional drawing

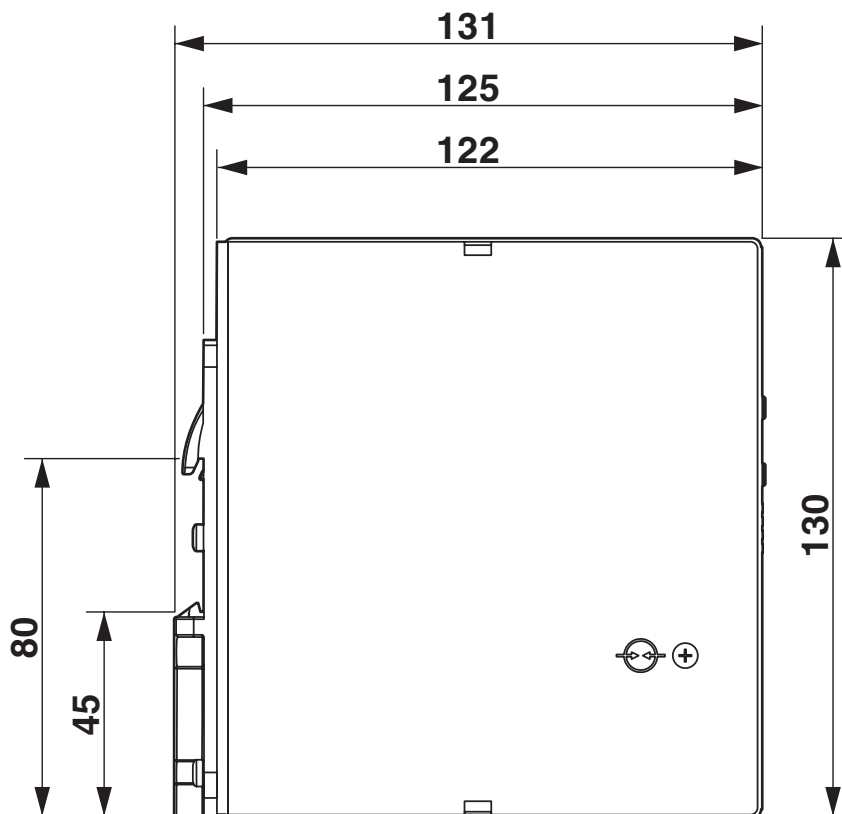



Schematic diagram

# Housing

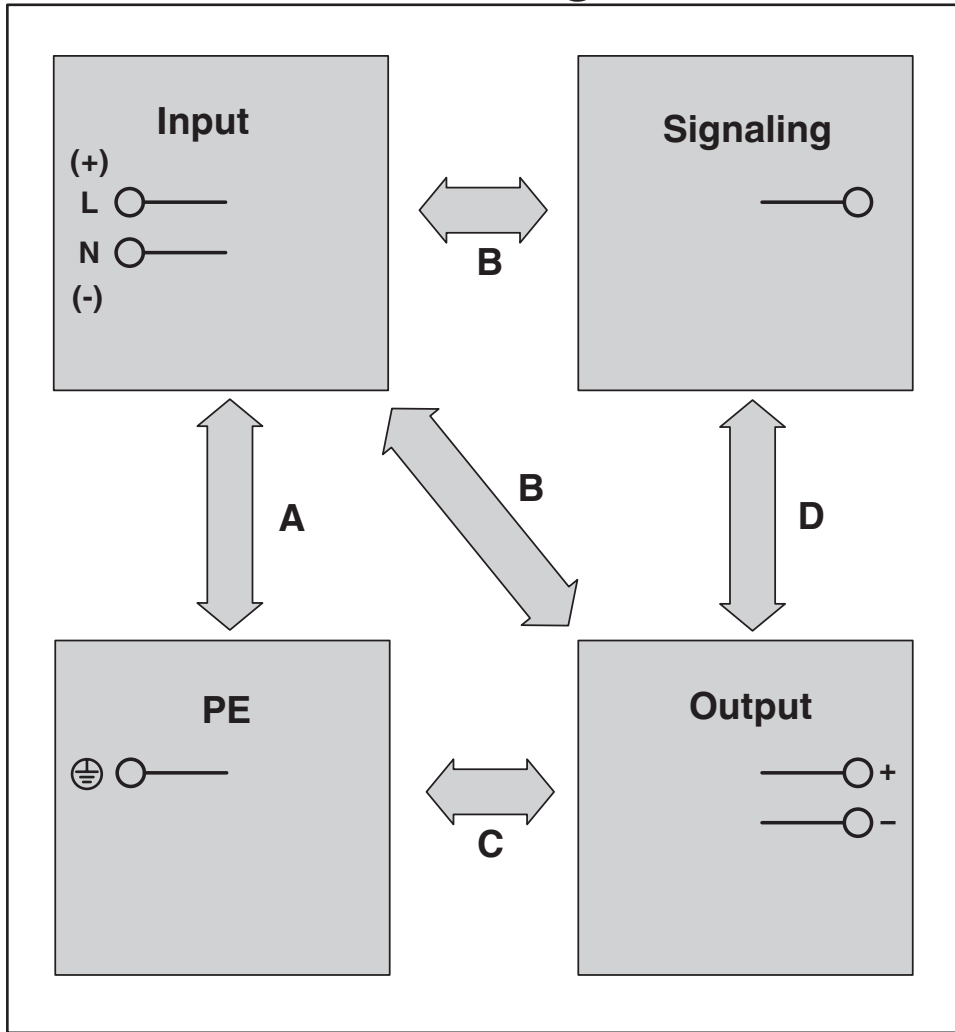

Diagram

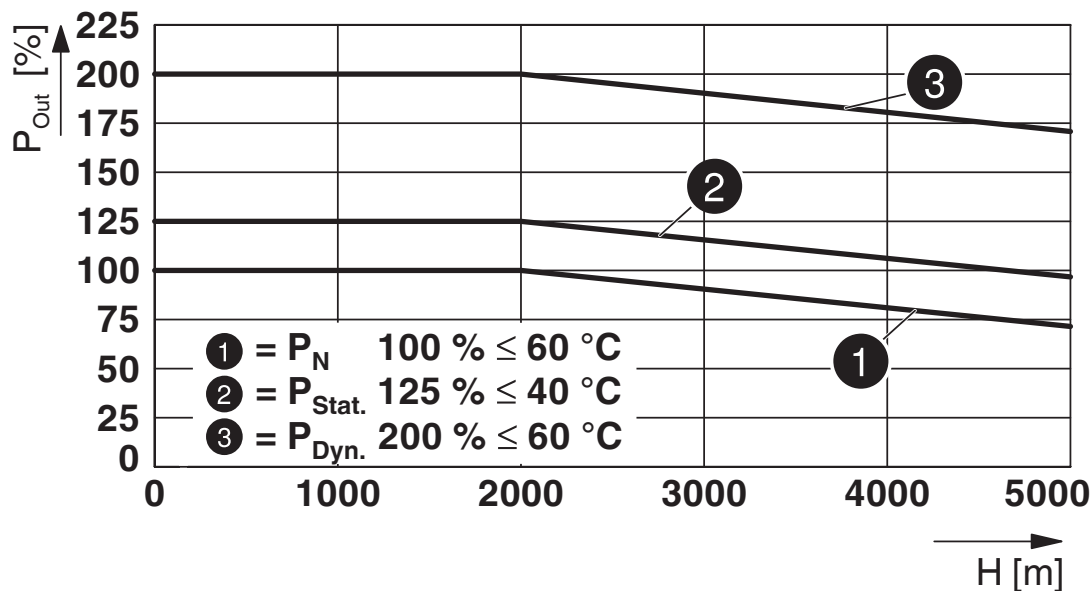

# QUINT4-PS/1AC/24DC/10/CO - Power supply unit



2904625

<https://www.phoenixcontact.com/us/products/2904625>

## Approvals

To download certificates, visit the product detail page: <https://www.phoenixcontact.com/us/products/2904625>



**cUL Recognized**  
Approval ID: E211944



**UL Recognized**  
Approval ID: E211944



**IECEE CB Scheme**  
Approval ID: SI-8863



**EAC**  
Approval ID: RU S-DE.BL08.W.00764



**LR**  
Approval ID: LR22472797TA



**NK**  
Approval ID: TA21182M



**BV**  
Approval ID: 44621/B0 BV



**UL Listed**  
Approval ID: E123528



**cUL Listed**  
Approval ID: E123528

**ABS**

Approval ID: 20-1973616-PDA



**Type approved**  
Approval ID: SI-SIQ BG 005/026

# QUINT4-PS/1AC/24DC/10/CO - Power supply unit



2904625

<https://www.phoenixcontact.com/us/products/2904625>



**EAC**

Approval ID: RU S-DE.BL08.W.00764

**DNV**

Approval ID: TAA00000BV



**cCSAus**

Approval ID: 70076166

**BIS Licence Document**

Approval ID: R-41268801



**cUL Listed**

Approval ID: E199827



**UL Listed**

Approval ID: E199827

**cULus Recognized**

**cULus Listed**

**cULus Listed**

# QUINT4-PS/1AC/24DC/10/CO - Power supply unit



2904625

<https://www.phoenixcontact.com/us/products/2904625>

## Classifications

### ECLASS

ECLASS-11.0	27040701
ECLASS-13.0	27040701
ECLASS-12.0	27040701

### ETIM

ETIM 9.0	EC002540
----------	----------

### UNSPSC

UNSPSC 21.0	39121000
-------------	----------

# QUINT4-PS/1AC/24DC/10/CO - Power supply unit



2904625

<https://www.phoenixcontact.com/us/products/2904625>

## Environmental product compliance

### EU RoHS

Fulfills EU RoHS substance requirements	Yes
Exemption	7(a), 7(c)-I

### EU REACH SVHC

REACH candidate substance (CAS No.)	Lead(CAS: 7439-92-1)
SCIP	69a3a485-76f2-44f0-b7c7-553867ca52c8

Phoenix Contact 2024 © - all rights reserved  
<https://www.phoenixcontact.com>

Phoenix Contact USA  
586 Fulling Mill Road  
Middletown, PA 17057, United States  
(+717) 944-1300  
[info@phoenixcon.com](mailto:info@phoenixcon.com)