

Features

- I Wide operating voltage (V1mA) range from 18V to 1800V
- I Fast responding to transient over-voltage.
- I Large absorbing transient energy capability.
- I Low clamping ratio and no following-on current.



General Information

- I Surge protection in consumer electronics
- I Surge protection in industrial electronics
- I Relay and electromagnetic valve surge absorption
- I Transistor, diode, IC, thyristor or triac semiconductor protection
- I Surge protection in electronic home appliances, gas and petroleum appliances

General Characteristics

- I Body: Nickel Plated
- I Devices with No Leads: Nickel Plated
- I Operating Temperature: -40°C to +85°C
- I Storage Temperature: -40 °C to +125°C
- I Axial Devices: Tin Plated

Part Number Code

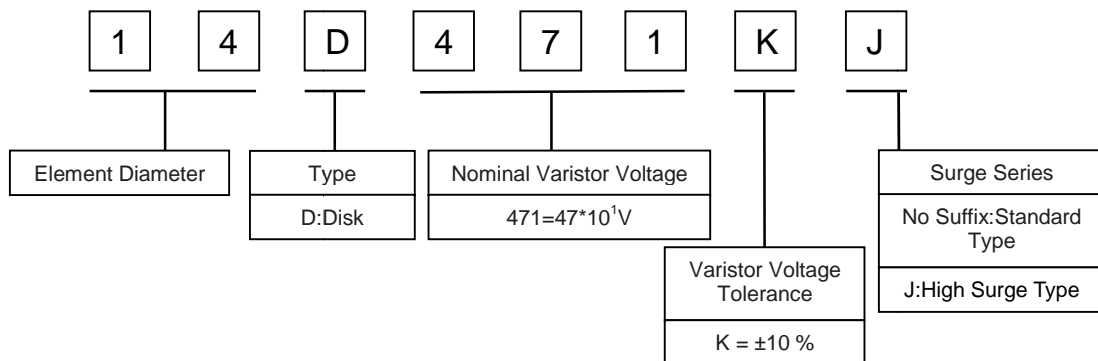

Electrical Characteristics

Type Number		Varistor Voltage	Max. Allowable Voltage		Max. Energy (10/1000µs)		Max. Clamping Voltage (8/20µs)		Withstanding Surge Current (8/20µs)		Rated Power	Typical Capacitance (Reference)
Standard	High Surge	V _{1mA} (V)	V _{AC} (V)	V _{DC} (V)	(J) Standard	(J) High Surge	I _p (A)	V _c (V)	I(A) Standard	I(A) High Surge	(W)	@1KHz(pf)
14D180K	/	15~22	11	14	5.7	/	10	38	1000	/	0.1	18000
14D220K	/	20~26	14	18	7.0	/	10	43	1000	/	0.1	15000
14D270K	/	24.3~31.1	17	22	8.5	/	10	53	1000	/	0.1	10000
14D330K	/	29.7~37.9	20	26	10	/	10	65	1000	/	0.1	8500
14D390K	/	35.2~44.8	25	31	12	/	10	77	1000	/	0.1	7500
14D470K	/	43~53	30	38	15	/	10	93	1000	/	0.1	6500
14D560K	/	51~63	35	45	18	/	10	110	1000	/	0.1	5600
14D680K	/	62~76	40	56	21	/	10	135	1000	/	0.1	4700
14D820K	14D820KJ	74~90	50	65	26	31	50	135	4500	6000	0.6	3900
14D101K	14D101KJ	90~110	60	85	32	38	50	165	4500	6000	0.6	3400
14D121K	14D121KJ	108~132	75	100	38	46	50	200	4500	6000	0.6	3100
14D151K	14D151KJ	135~165	95	125	47	56	50	250	4500	6000	0.6	3000
14D181K	14D181KJ	162~198	115	150	57	60	50	300	4500	6000	0.6	1030
14D201K	14D201KJ	185~225	130	170	63	82	50	340	4500	6000	0.6	970
14D221K	14D221KJ	198~242	140	180	69	90	50	360	4500	6000	0.6	840
14D241K	14D241KJ	216~264	150	200	76	98	50	395	4500	6000	0.6	710
14D271K	14D271KJ	243~297	175	225	85	116	50	455	4500	6000	0.6	650
14D301K	14D301KJ	270~330	195	250	95	128	50	505	4500	6000	0.6	600
14D331K	14D331KJ	297~363	210	275	104	140	50	550	4500	6000	0.6	550
14D361K	14D361KJ	324~396	230	300	113	158	50	595	4500	6000	0.6	500
14D391K	14D391KJ	351~429	250	320	123	170	50	650	4500	6000	0.6	480
14D431K	14D431KJ	387~473	275	350	136	185	50	710	4500	6000	0.6	440
14D471K	14D471KJ	423~517	300	385	148	205	50	775	4500	6000	0.6	420
14D511K	14D511KJ	459~561	320	418	148	220	50	842	4500	6000	0.6	390
14D561K	14D561KJ	504~616	350	460	148	240	50	920	4500	6000	0.6	360
14D621K	14D621KJ	558~682	385	505	148	250	50	1025	4500	6000	0.6	320
14D681K	14D681KJ	612~748	420	560	148	260	50	1120	4500	6000	0.6	290
14D751K	14D751KJ	675~825	460	615	158	270	50	1240	4500	6000	0.6	260
14D781K	14D781KJ	702~858	485	640	164	275	50	1290	4500	6000	0.6	230
14D821K	14D821KJ	738~902	510	670	172	280	50	1355	4500	6000	0.6	230
14D911K	14D911KJ	819~1001	550	745	191	295	50	1500	4500	6000	0.6	200
14D951K	14D951KJ	855~1045	580	780	199	305	50	1570	4500	6000	0.6	190
14D102K	14D102KJ	900~1100	625	825	210	335	50	1650	4500	6000	0.6	180
14D112K	14D112KJ	990~1210	680	895	231	360	50	1815	4500	6000	0.6	150
14D142K	14D142KJ	1260~1540	870	1150	295	370	50	2310	4500	6000	0.6	140
14D152K	14D152KJ	1350~1650	900	1220	312	375	50	2475	4500	6000	0.6	140
14D182K	14D182KJ	1620~1980	1000	1465	378	450	50	2970	4500	6000	0.6	120



Electrical Ratings

Items	Test Condition/Description	Requirement					
Varistor Voltage	The voltage between two terminals with the specified measuring current 1mA.DC applied is called Vb.						
Maximum Allowable Voltage	The recommended maximum sine wave voltage (RMS) or the Maximum DC voltage can be applied continuously.						
Maximum Clamping Voltage	<p>The maximum voltage between two terminals with the specification standard impulse current. Applied waveform: 8/20μs</p> <p style="text-align: center;"> $T_1=1.25 \cdot T=8\mu s \pm 20\%$ $T_2=20\mu s \pm 20\%$ </p>		To meet the Specified value				
Rated Wattage	The maximum average power that can be applied within the specified ambient temperature.						
Energy	The maximum energy within the varistor voltage change of ±10% when one impulse of 10/1000μs or 2ms is applied.						
Withstanding Surge Current	The maximum current within the varistor voltage change of ±10% with the standard impulse current (8/20μs) applied one time.						
Surge Life	<p>The change of Vb shall be measured after the impulse listed below which is applied 10,000 times continuously with the interval of ten seconds at room temperature.</p> <table border="1" style="margin-left: auto; margin-right: auto;"> <tbody> <tr> <td rowspan="2" style="text-align: center;">14Φ series</td> <td style="text-align: center;">180K to 680K</td> <td style="text-align: center;">75A (8/20μs)</td> </tr> <tr> <td style="text-align: center;">820K to 182K</td> <td style="text-align: center;">150A (8/20μs)</td> </tr> </tbody> </table>	14Φ series	180K to 680K	75A (8/20μs)	820K to 182K	150A (8/20μs)	$\frac{\Delta V_b}{V_b} \leq \pm 10\%$
14Φ series	180K to 680K		75A (8/20μs)				
	820K to 182K	150A (8/20μs)					



Soldering Recommendation

Wave Lead Free Soldering Recommendation

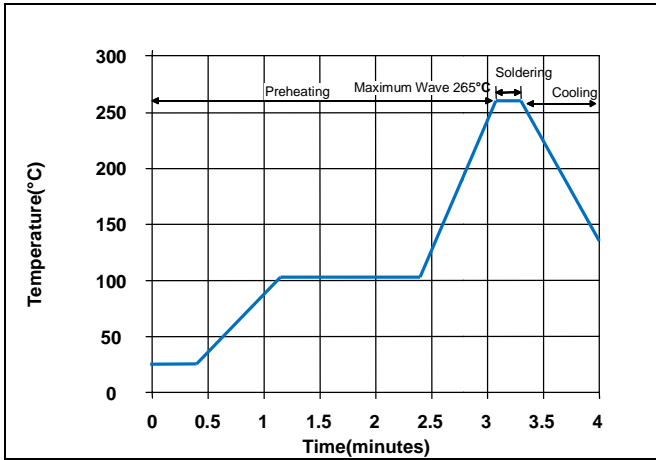

Item	Conditions
Peak Temperature	265°C
Dipping Time	10 seconds (max.)
Soldering	1 time

Recommendation Reworking Conditions with Soldering Iron

Item	Conditions
Temperature of Soldering Iron-tip	360°C (max.)
Soldering Time	3 seconds (max.)
Distance from Varistor	2mm (min.)

Dimensions

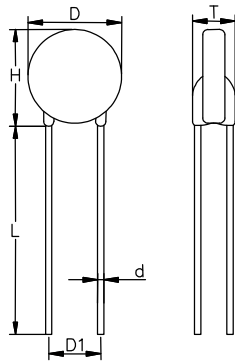

Symbol	Millimeters	Inches
H(max)	20.0	0.787
L(min)	15.0	0.591
D(max)	17.0	0.669
D1(±1.0)	7.5	0.295
T(max)	TABLE 2	
d(±0.1)	0.8	0.031

Packaging Quantity: 250pcs/bag

TABLE 2---T(max.)

Model	Millimeters	Inches	Model	Millimeters	Inches
18V~39V	4.6	0.181	430V~560V	6.2	0.244
47V~68V	5.1	0.201	620V~780V	7.2	0.283
82V~150V	4.6	0.181	820V~1200V	8.4	0.331
180V~270V	5.1	0.201	1300V~1500V	9.5	0.374
330V~390V	5.6	0.220	1600V~1800V	11.3	0.445

