

# **EV\_ICU-20201-00**

## **Evaluation Board User Guide**

# Table of Contents

- 1 SCOPE AND PURPOSE .....3**
- 2 EV\_ICU-20201-00 EVALUATION BOARD .....3**
  - 2.1 PIN ASSIGNMENTS.....3
  - 2.2 ELECTRICAL SPECIFICATIONS.....3
  - 2.3 SCHEMATIC.....4
  - 2.4 BILL OF MATERIALS.....4
  - 2.5 TEST POINT LOCATION .....5
- 3 MECHANICAL SPECIFICATIONS.....5**
  - 3.1 PCBA DIMENSIONS .....5
  - 3.2 ACOUSTIC HOUSING .....6
- 4 CONFIGURATION, PROGRAMMING, AND OPERATION.....6**
  - 4.1 CONFIGURATION AND PROGRAMMING .....6
  - 4.2 OPERATION.....6
- 5 REVISION HISTORY.....7**

# Table of Figures

- Figure 1. EV\_ICU-20201-00 Evaluation Board.....3
- Figure 2. Schematic .....4
- Figure 3. Test Point Location.....5
- Figure 4. Dimensions of the EV\_ICU-20201-00 Assembly.....5

# List of Tables

- Table 1. Connector Pinout .....3
- Table 2. Bill of Material .....4
- Table 3. Recommended Flat Flex Cable and Connector .....4
- Table 4. Geometric Dimensions for EV\_ICU-20201-00 .....5

## 1 SCOPE AND PURPOSE

This document details the specification, programming, operation, and basic performance of an EV\_ICU-20201-00 ultrasonic sensor evaluation board. This board incorporates the ICU-20201 Ultrasonic Sensor device with PCB, two capacitors and an connector.



Figure 1. EV\_ICU-20201-00 Evaluation Board

## 2 EV\_ICU-20201-00 EVALUATION BOARD

### 2.1 PIN ASSIGNMENTS

Table 1. Connector Pinout

PIN	NAME	DESCRIPTION
1	VDD	Digital Logic Supply. Connect to externally regulated 1.8V $\pm$ 5% supply.
2	GND	Ground
3	MUTCLK	External Input/Output 16x Operating Frequency Reference Clock (optional)
4	RTC_CLK/LFCLK	External Input/Output Low Frequency Reference Clock - 32.768kHz typical (optional)
5	INT2	Interrupt Request Open Drain Input/Output 2
6	INT1	Interrupt Request Open Drain Input/Output 1
7	CS_B	SPI Chip Select (active-low, from external SPI host)
8	MISO	MCU In Sensor Out serial data (to external SPI host)
9	MOSI	MCU Out Sensor In serial data (from external SPI host)
10	SCLK	SPI Interface Clock (from external SPI host) CPOL=1, CPHA=1
11	GND	Ground
12	VDDIO	I/O Power Supply. Connect to externally regulated 1.71V ~ 3.63V supply.
13	GND (pad)	Ground
14	GND (pad)	Ground

### 2.2 ELECTRICAL SPECIFICATIONS

Please refer to DS-000478 ICU-20201 Datasheet for information on the device's electrical characteristics. Please note that the ICU-20201 electrical specifications in the datasheet still apply with different suffixes.

## 2.3 SCHEMATIC

Electrical connection to the EV\_ICU-20201-00 board is via a 12-pin 0.5 mm pitch flat flex cable (FFC) connector. The electrical schematic of the board, including the connector pinout and the connections to the ICU-20201 sensor, is shown in Figure 2. Part numbers for the FFC connector and the recommended FFC cable correspond to the bill of materials listed in Section 2.4. Refer to the ICU-20201 datasheet and application notes for additional information on electrical connections and operation.

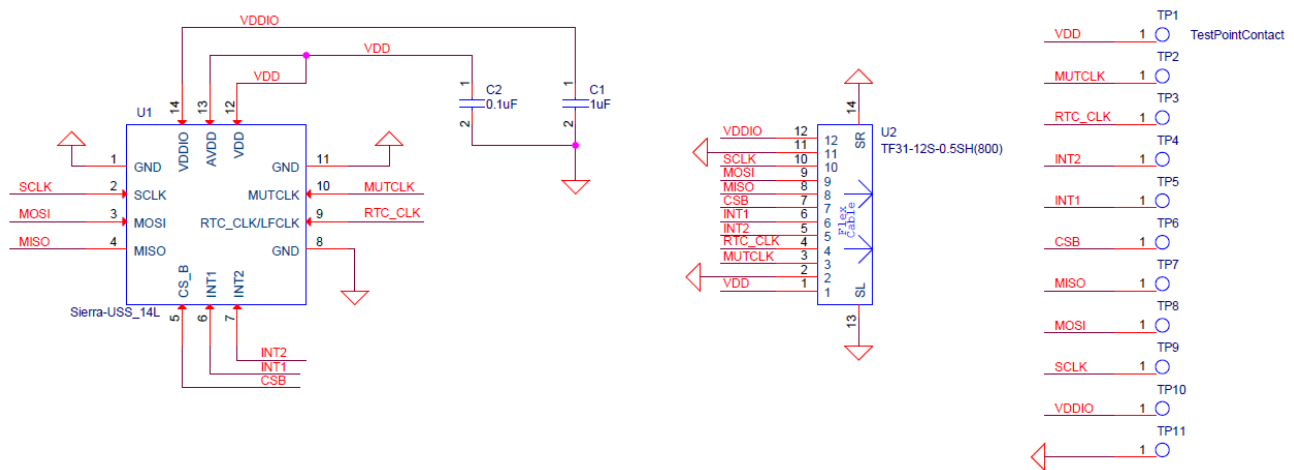

Figure 2. Schematic

## 2.4 BILL OF MATERIALS

Table 2. Bill of Material

QTY	REFERENCE	PART	PCB FOOTPRINT	MANUFACTURER	MANUFACTURER PART NUMBER
1	PCB	PCB, ICU-X201	N/A	TDK	100-06316
1	U1	ICU-20201	14-pin	TDK	ICU-20201
1	U2	CONN FFC 12POS 0.50MM SMD	12-pin, 0.50mm pitch	Hirose Electric Co Ltd	TF31-12S-0.5SH(800)
1	C1	CAP CER 1UF 16V 10% X6S 0402	0402	TDK	C1005X6S1C105K050BC
1	C2	CAP CER 0.1UF 25V 10% X7R 0402	0402	TDK	C1005X7R1E104K050BB

Table 3. Recommended Flat Flex Cable and Connector

FLAT CABLE CONNECTOR TYPE	<a href="#">Hirose: TF31-12S-0.5SH(800) Datasheet</a>
RECOMMENDED FLAT CABLE	<a href="#">MultiComp Pro: MP-FFCA05123052A Datasheet</a>

## 2.5 TEST POINT LOCATION

If FFC is not a viable solution, the PCB can be wired out using the test points on the PCB. See Figure 3 for test point location and refer to Figure 2 for schematic. For debugging purposes, a breakout board, 100-06407, can be requested to probe out each connection.

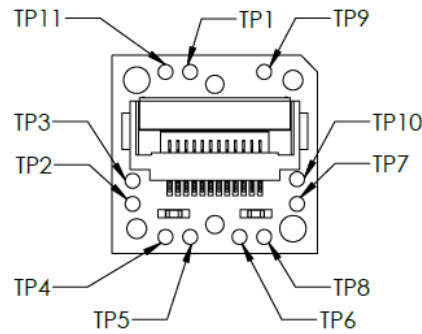

Figure 3. Test Point Location

## 3 MECHANICAL SPECIFICATIONS

### 3.1 PCBA DIMENSIONS

The outer dimensions of the EV\_ICU-20201-00 assembly are shown in Figure 4. The ICU-20201 package size is 3.50 x 3.50 x 1.26 mm. During transducer operation the port must not be blocked. The sensor's port may only be covered by a particle ingress filter (PIF).

Table 4. Geometric Dimensions for EV\_ICU-20201-00

EV_ICU-20201-00	DIMENSION	UNIT
ICU-20201 Package Size	3.50 x 3.50 x 1.26	mm
Maximum PCB width	12.15	mm
Maximum PCB length	12.65	mm

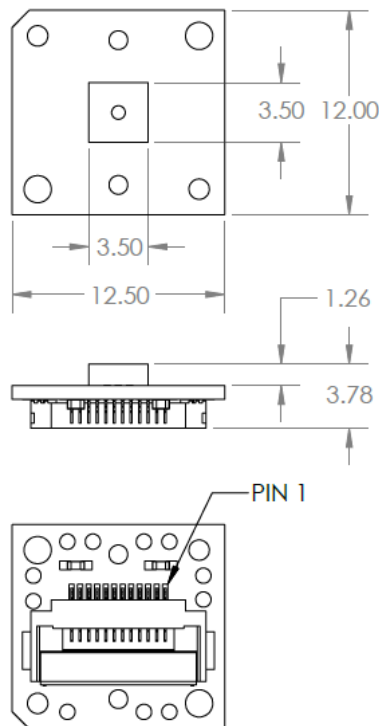

Figure 4. Dimensions of the EV\_ICU-20201-00 Assembly

## **3.2 ACOUSTIC HOUSING**

The evaluation board will need an acoustic housing to interface to the IC. Please refer to AN-000337 CH201 and ICU-20201 Acoustic Housing Reference Designs for acoustic housing and beam patterns of reference housings.

# **4 CONFIGURATION, PROGRAMMING, AND OPERATION**

Please refer to DS-000478 ICU-20201 Datasheet for information on the device's electrical characteristics.

## **4.1 CONFIGURATION AND PROGRAMMING**

Please refer to the following documents for configuration and programming information:

- AN-000175 SonicLib Programmers Guide
- AN-000329 ICU-x0201 Hello Chirp Example User Guide

## **4.2 OPERATION**

Please refer to the following documents for operation information:

- AN-000398 ICU-20201 EVK Platform User Guide

## 5 REVISION HISTORY

REVISION DATE	REVISION	DESCRIPTION
01/18/2023	1.0	Initial Release

This information furnished by InvenSense or its affiliates (“TDK InvenSense”) is believed to be accurate and reliable. However, no responsibility is assumed by TDK InvenSense for its use, or for any infringements of patents or other rights of third parties that may result from its use. Specifications are subject to change without notice. TDK InvenSense reserves the right to make changes to this product, including its circuits and software, in order to improve its design and/or performance, without prior notice. TDK InvenSense makes no warranties, neither expressed nor implied, regarding the information and specifications contained in this document. TDK InvenSense assumes no responsibility for any claims or damages arising from information contained in this document, or from the use of products and services detailed therein. This includes, but is not limited to, claims or damages based on the infringement of patents, copyrights, mask work and/or other intellectual property rights.

Certain intellectual property owned by InvenSense and described in this document is patent protected. No license is granted by implication or otherwise under any patent or patent rights of InvenSense. This publication supersedes and replaces all information previously supplied. Trademarks that are registered trademarks are the property of their respective companies. TDK InvenSense sensors should not be used or sold in the development, storage, production or utilization of any conventional or mass-destructive weapons or for any other weapons or life threatening applications, as well as in any other life critical applications such as medical equipment, transportation, aerospace and nuclear instruments, undersea equipment, power plant equipment, disaster prevention and crime prevention equipment.

©2023 InvenSense. All rights reserved. InvenSense, SmartMotion, MotionProcessing, MotionProcessor, SensorStudio, UltraPrint, MotionTracking, CHIRP Microsystems, SmartBug, SonicLink, Digital Motion Processor, AAR, and the InvenSense logo are registered trademarks of InvenSense, Inc. The TDK logo is a trademark of TDK Corporation. Other company and product names may be trademarks of the respective companies with which they are associated.



©2023 InvenSense. All rights reserved.