

Series

POSITIONER
PER M22520/2-11

Issue:
Sept 19, 2008

Page
1/1

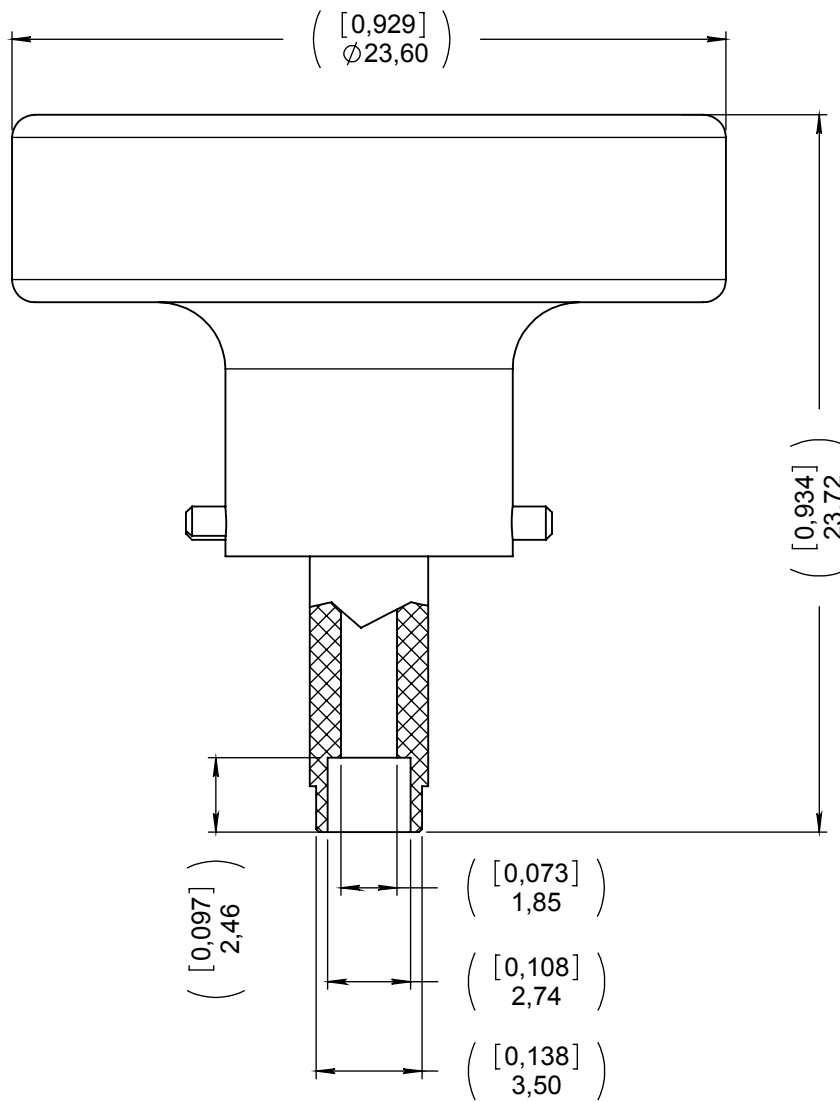
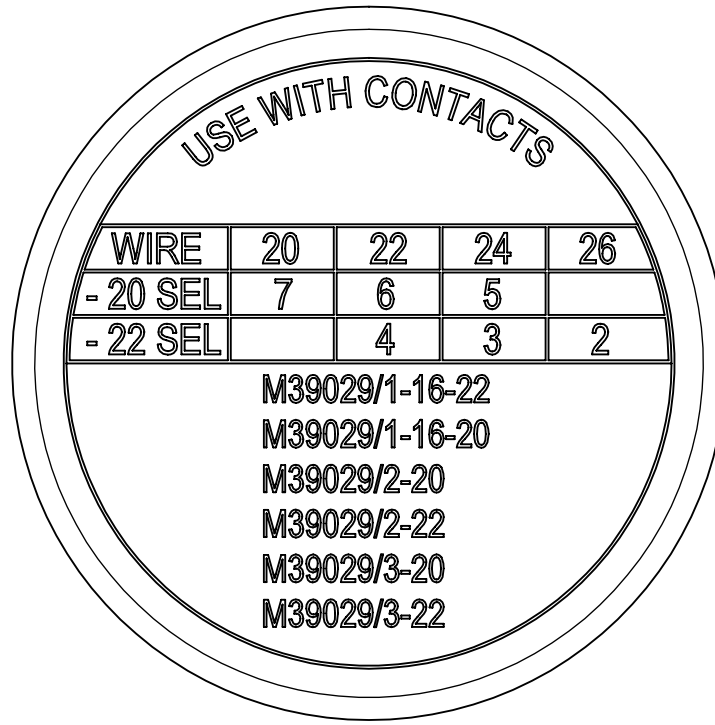

Used with crimping tool :
M22520/2-01
RADIAL P/N : 282 281

DIMENSIONS : mm [inch] are given for information only

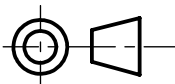

Confidential information not to be disclosed to third parties without Radial approval. This information is given as an indication. In the continual goal to improve our products, we reserve the right to make any modifications judged necessary.

4112_9311

CREATION				
PEN: 2008-09-1768A				
NOM: PAILOT N.				
DATE: Sept 19, 2008				
APPR.: PESSARD M.	/	/	/	/
Issue	Revisions	Name	Approved	

Mouser Electronics

Authorized Distributor

Click to View Pricing, Inventory, Delivery & Lifecycle Information:

[Radial:](#)

[282581015](#)