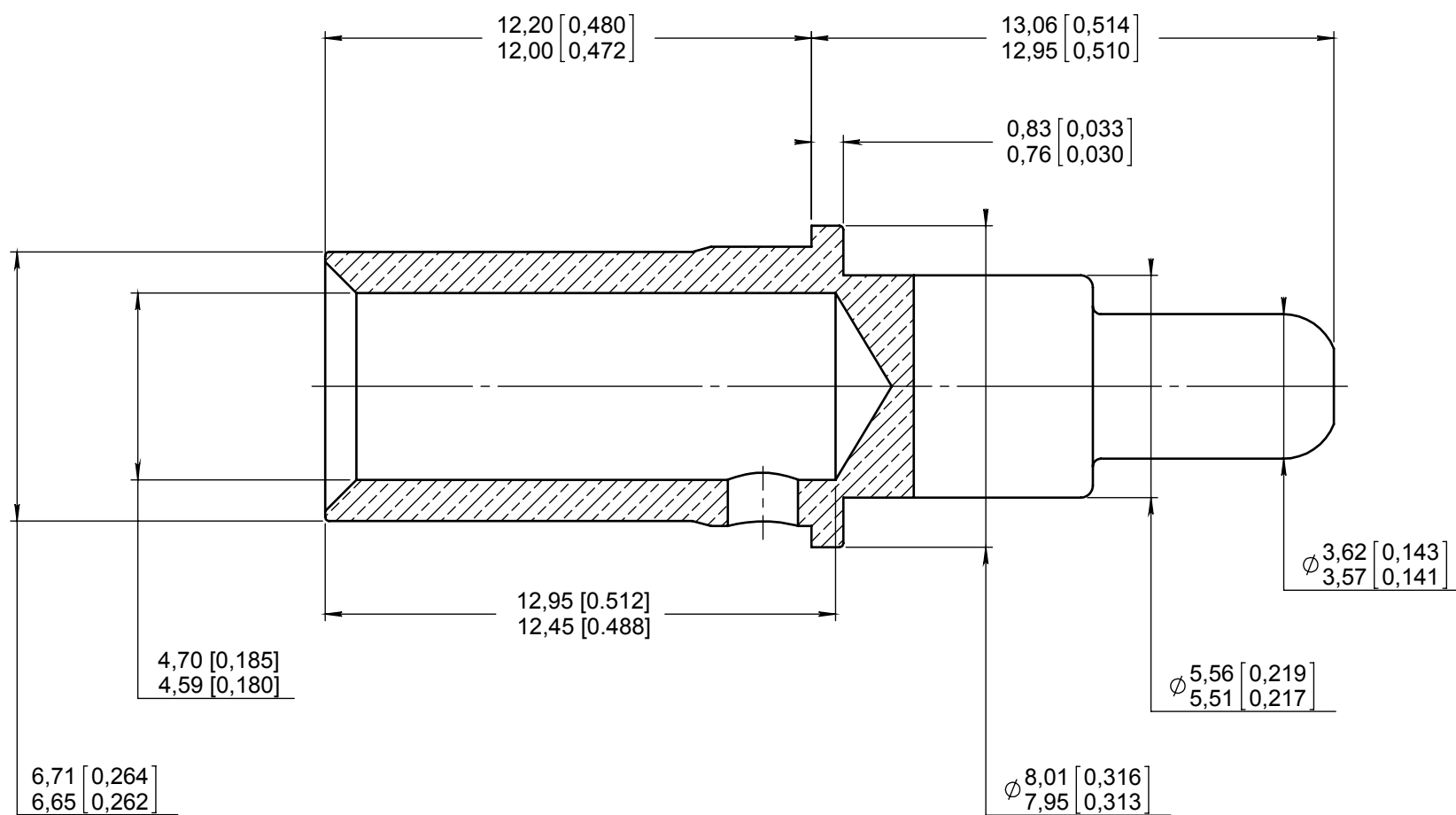
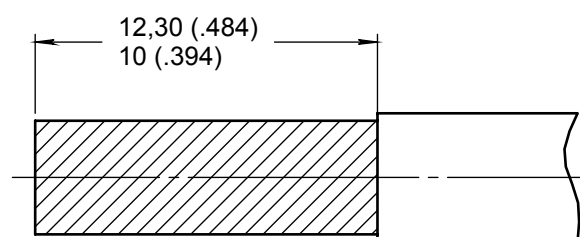

Series
EPXB

Size 8 crimp pin contact

Issue:
 Jul. 12, 2018

Page
1/1

Cable stripped length:

MATERIAL AND FINISH: COPPER ALLOY PER UNS C18700 CHEMICAL COMPOSITION AND GOLD OVER NICKEL.

 CRIMPING TOOL : M22520/23-01
 DIE SET : M22520/23-02
 LOCATOR: RADIALL P/N: 282 588
 REMOVABLE TOOL : RADIALL P/N: 282 549 001

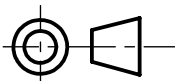
Note:

In order to ensure the SAE AS39029 tensile strength requirements for any wire plating, RADIALL recommend to use MS3348-8-10 bushing when crimped to AWG 10 cable.

DIMENSIONS : mm (inch are given for information only)

Estimated weight : 4 g

CREATION				
PEN: M060400099A				
	Jul. 12, 18	Dimensions corrected, in accordance with standard EN3155-076	Lopez C.	Weihls H.
NOM: PAILOT N.		Feb. 23, 18	Material note updated	Moutault W. Legloahec
DATE: Oct 17, 2006		Oct 20, 14	Note added	YON P. VIEIRA D.
APPR.: PESSARD M.		Jan. 07, 13	Dimensions corrected, in accordance with standard EN3155-076	Vieira Legloahec
	Issue	Revisions	Name	Approved

Mouser Electronics

Authorized Distributor

Click to View Pricing, Inventory, Delivery & Lifecycle Information:

[Radial:](#)

[617291002](#)