

## Low Voltage Brushless DC Blowers

### 3.0" (76mm) BLDC Low-Voltage Blower

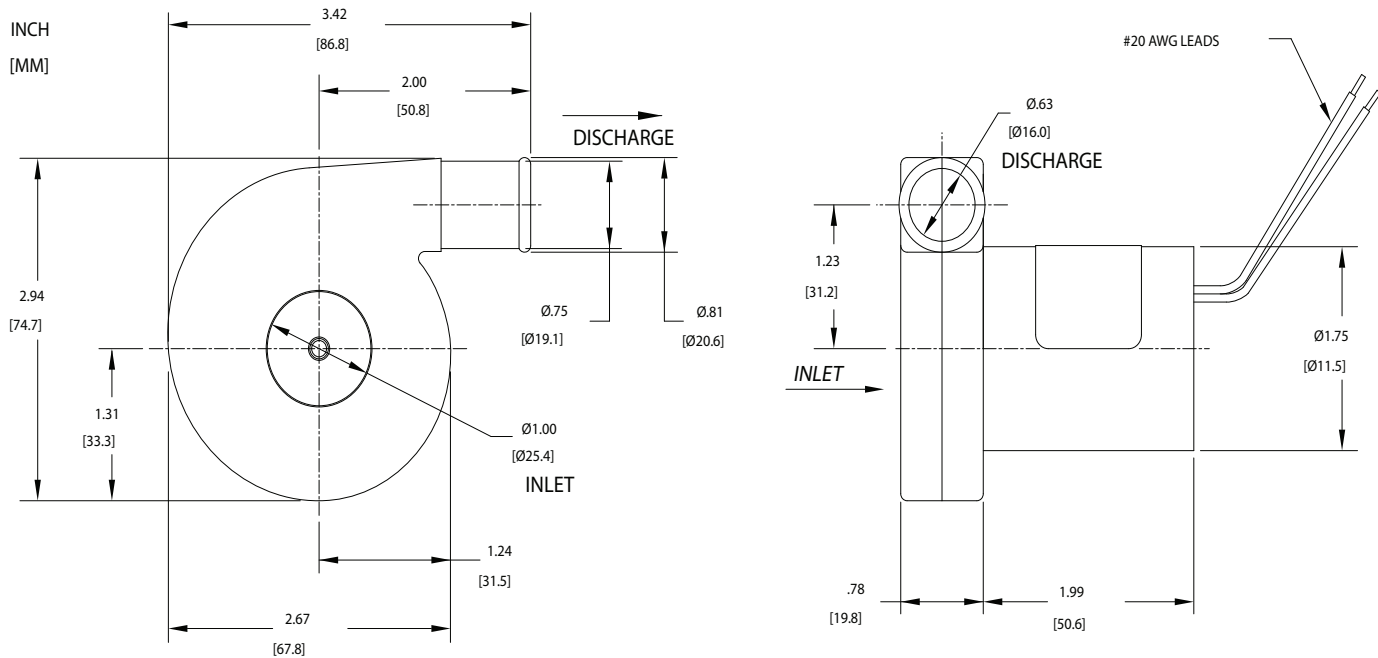

12/24 VDC



Specification	Units	Part/ Model Number	
		119349	119350
Voltage	VDC	6-14	16-28
Stages	-	1	1
Max Sealed Pressure	in. H <sub>2</sub> O	13.4	14.0
	mbar	33.4	34.9
Max Open Flow Rate	CFM	19.8	20.6
	m <sup>3</sup> /hr	33.7	35

#### Notes:

- **Temperature:** Working Air: 0°C to 45°C, Ambient Air: 0°C to 45°C, Storage: -40°C to 85°C.
- Customized performance available upon request. Please contact AMETEK Technical & Industrial Products' Marketing and Sales Department.
- When used as a vacuum, the blower performance might be less than shown herein, depending on the operating point.
- Please observe proper polarity for power connections. Improper connections will damage the blower's electronics.
- **Optional** - Motor configuration available with connection to external controller.
- **Optional** - 2-Wire Operation: The 3.0, 3.3, 4.5 inch Windjammers operate with a simple two-wire configuration. The blower speed is directly proportional to the supply voltage, and there is no separate speed command signal input or speed setting via potentiometer. The supply voltage powers both the motor winding and the motor controller. Operating points below the minimum supply voltage stated in the chart above can be achieved by providing a third wire to power the motor controller separately from the motor winding. This feature is available upon request.
- **Weight** = 9 oz. / .3 Kg

**Optional Tachometer Output:** A square wave output whose signal is 2x the blower rotational frequency

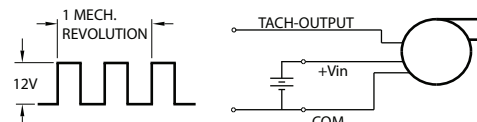

This document is for informational purposes only and should not be considered as a binding description of the products or their performance in all applications. The performance data on this page depicts typical performance under controlled laboratory conditions. AMETEK is not responsible for blowers driven beyond factory specified speed, temperature, pressure, flow or without proper alignment. Actual performance will vary depending on the operating environment and application. AMETEK products are not designed for and should not be used in medical life support applications. AMETEK reserves the right to revise its products without notification. The above characteristics represent standard products. For product designed to meet specific applications, contact AMETEK Dynamic Fluid Solutions Sales department.



Typical Performance

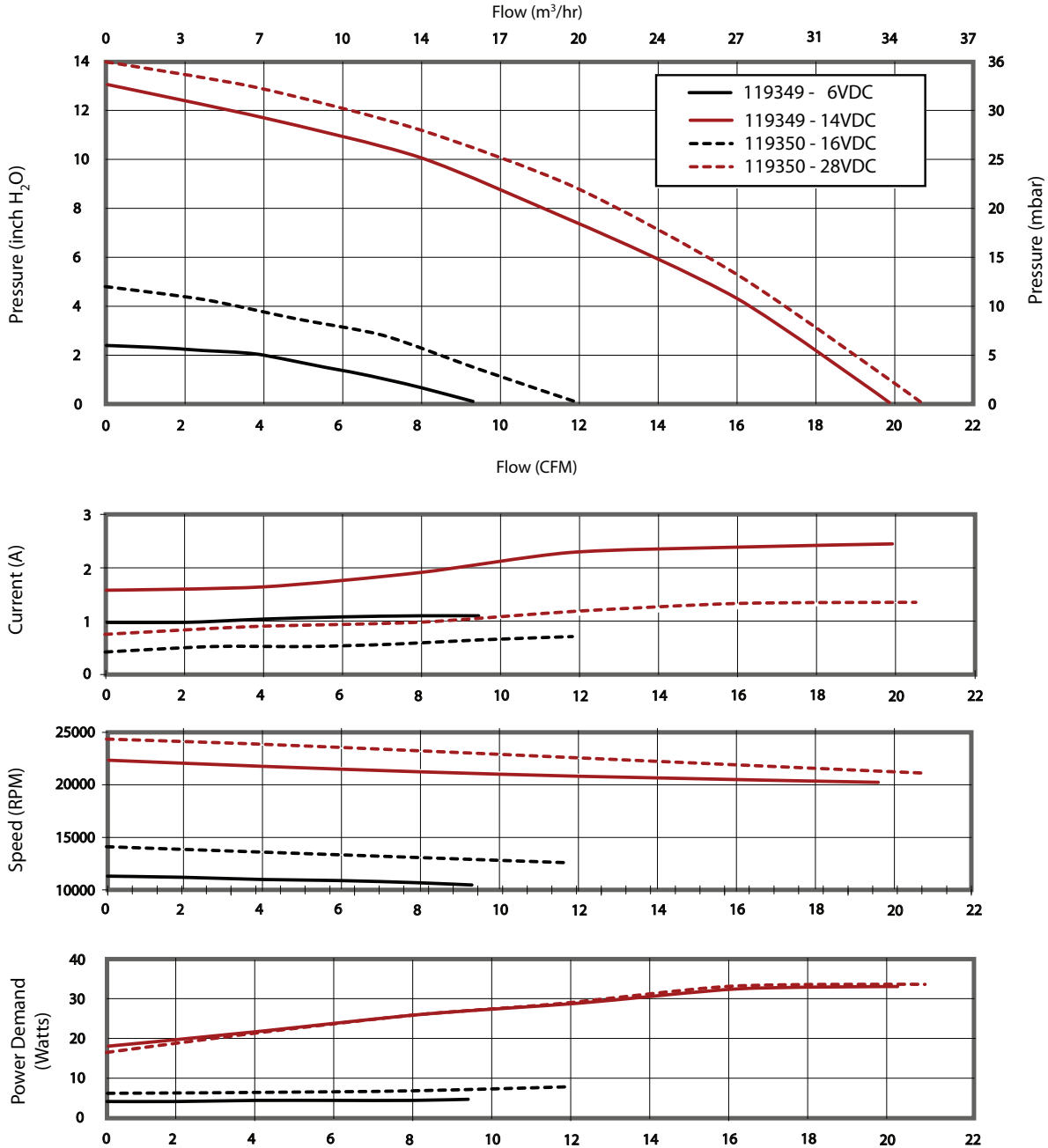

Data presented represents blower performance at STANDARD AIR DENSITY, .075 lb/ft<sup>3</sup> (29.92" Hg, Sea Level, 68° F)  
 Vacuum performance available upon request.

*This document is for informational purposes only and should not be considered as a binding description of the products or their performance in all applications. The performance data on this page depicts typical performance under controlled laboratory conditions. AMETEK is not responsible for blowers driven beyond factory specified speed, temperature, pressure, flow or without proper alignment. Actual performance will vary depending on the operating environment and application. AMETEK products are not designed for and should not be used in medical life support applications. AMETEK reserves the right to revise its products without notification. The above characteristics represent standard products. For product designed to meet specific applications, contact AMETEK Dynamic Fluid Solutions Sales department.*