

NOTES:

1. MATERIAL:
 - 1.1. HOUSING: LCP ,COLOR IS BLUE;
 - 1.2. CONTACT: BRASS (H65 T=0.20&0.25mm);
 - 1.3. SHELL: COLD ROLLED IRON (SPCC T=0.30mm);
2. ELECTRICAL:
 - 4.1. VOLTAGE RATING: 30V DC ;
 - 4.2. CURRENT RATING: 1.5A ;
 - 4.3. CONTACT RESISTANCE: 30MILLIOHMS MAX.;
 - 4.4. WITHSTAND VOLTAGE: 100V AC RMS 50(60)Hz,1MIN.;
 - 4.5. INSULATION RESISTANCE: 100MEGΩHMS MIN @500V DC;
5. MECHANICAL:
 - 5.1. MATING FORCE: 35N MAX.;
 - 5.2. UNMATING FORCE: 5~35N ;
 - 5.3. OPERATING LIFE: 1500 CYCLES MIN.;
6. PLATING:
 - 6.1. TERMINAL:
 - NI PLATING OVER ALL,
 - Tin PLATING ON SOLDER AREA,
 - Au G/Fu" ON CONTACT AREA;
 - 6.2. SHELL: NI PLATING OVER ALL;
7. ENVIRONMENTAL:
 - 7.1. STORAGE TEMPERATURE RANGE: -40°C~+85°C;
 - 7.2. OPERATION TEMPERATURE RANGE: -25°C~+70°C;

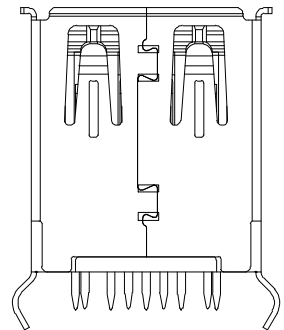
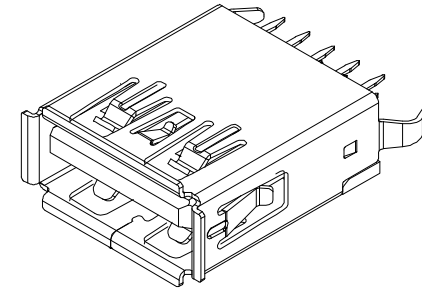
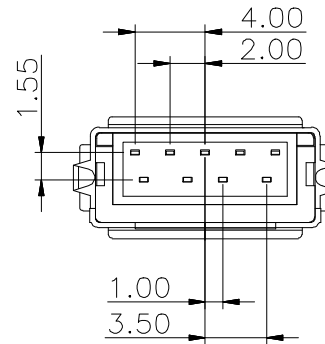
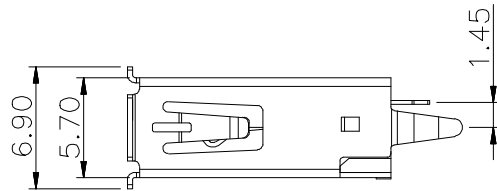
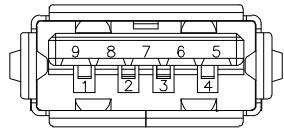

PIN NUMBER	SIGNAL NAME
PIN 1	Vbus
PIN 2	D-
PIN 3	D+
PIN 4	GND
PIN 5	Std_SSRX-
PIN 6	Std_SSRX+
PIN 7	GND_DRAIN
PIN 8	Std_SSTX-
PIN 9	Std_SSTX+
SHELL	GND

			GENERAL TOLERANCE	制图 DRAWING	深圳市华灿天禄电子有限公司 ShenzhenhuacantianluELECTRONICS CO.,LTD				
			DIM TOL	审核 CHECK					
			X.X ±0.30	批准 APPROVAL	产品名称 TITLE	TYPE AF 9P 3.0 180° L15.0mm 卷边 K脚15.2	版本 REV.	A	
1	初版发行		X.XX ±0.20	比例 SCALE	产品料号 PART NO.	HC-ST-003-010-L15.0-J-K	单位 UNITS	mm	
序号 No.	变更内容 MODIFY CONTENT	日期 MODIFY DATE	X.XXX ±0.10	投影 Projection	材料 MATERIAL		页次 SHEET	1/1	
			Angle ±3.0°						