

GENERAL DESCRIPTION

The TPS562201DDCR is a fully integrated , high-efficiency 2.0A synchronous rectified step-down converter . The TPS562201DDCR operates at high efficiency over a wide output current load range. This device offers two operation modes , PWM control and PFM Mode switching control ,which allows a high efficiency over the wider range of the load. The TPS562201DDCR requires a minimum number of readily available standard external components and is available in a 6-pin SOT23-6 ROHS compliant package.

APPLICATIONS

- Distributed Power Systems
- Digital Set Top Boxes
- Flat Panel Television and Monitors
- Notebook computer
- Wireless and DSL Modems

FEATURES

- High Efficiency: Up to 95%@5V
- 600kHz Frequency Operation
- 2.0A Output Current
- No Schottky Diode Required
- 3.5V to 18V Input Voltage Range
- 0.8V Reference
- Slope Compensated Current Mode Control for Excellent Line and Load Transient Response
- Integrated internal compensation Stable with Low ESR Ceramic Output Capacitors
- Over Current Protection with Hiccup-Mode
- Input overvoltage protection (OVP)
- Thermal Shutdown
- Inrush Current Limit and Soft Start
- Available in SOT23-6 Package

Pin Assignments

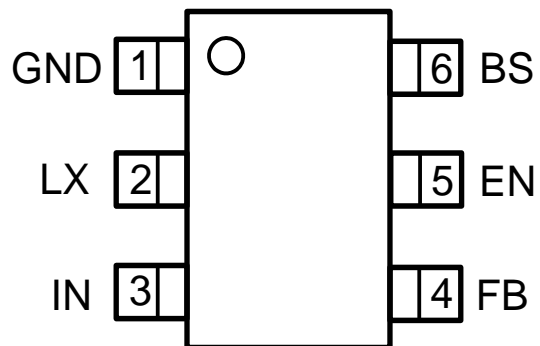

Reference News

Type No	MARKING
TPS562201DDCR	S42B***

Top Mark: S42B*** (S42B: Device Code, ***: Inside Code)

PIN FUNCTIONS

Pin	Name	Function
1	GND	Ground Pin
2	LX	Switching Pin
3	IN	Power supply Pin
4	FB	Output Voltage feedback input. Connect FB to the center point of the external resistor divider.
5	EN	Drive this pin to a logic-high to enable the IC. Drive to a logic-low to disable the IC and enter micro-power shutdown mode. Don't floating this pin.
6	BS	Bootstrap. A capacitor connected between LX and BST pins is required to form a floating supply across the high-side switch driver.

TYPICAL APPLICATION

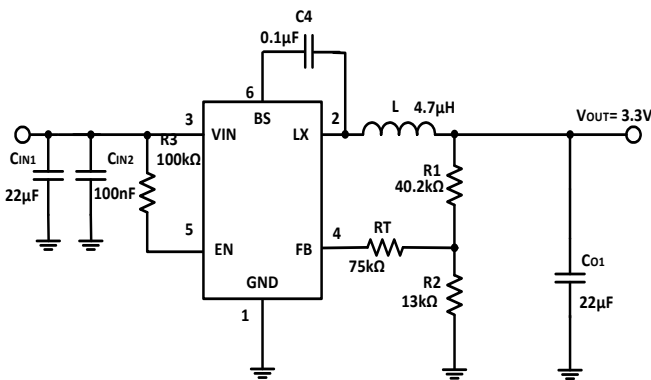
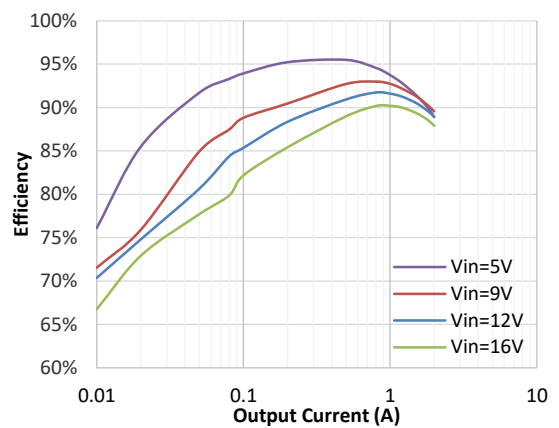

Figure 1. Basic Application Circuit

Efficiency

$V_{OUT}=3.3V$, $I_{OUT}=0.01A$ to $2A$, $T_A=25^\circ C$



ABSOLUTE MAXIMUM RATINGS (Note 1)

Parameter	Min	Max	Unit
Input Supply Voltage, EN	-0.3	20	V
LX Voltages	-0.3	20	V
FB Voltage	-0.3	6	V
BS Voltage	-0.6	25	V
Storage Temperature Range	-65	150	°C
Junction Temperature (Note 2)		160	°C
Power Dissipation		1000	mW
Lead Temperature (Soldering,10s)		260	°C

ESD RATING

Items	Description	Value	Unit
V _{ESD}	Human Body Model for all pins	±2000	V

JEDEC specification JS-001

RECOMMENDED OPERATING CONDITIONS

Items	Description	Min	Max	Unit
Voltage Range	IN Voltage	3.5	18	V
T _J	Operating Junction Temperature	-40	125	°C

THERMAL RESISTANCE (Note 3)

Items	Description	Value	Unit
θ _{JA}	Junction-to-ambient thermal resistance	130	°C/W

ELECTRICAL CHARACTERISTICS

(V_{IN}=12V, V_{OUT}=5V, T_A = 25°C, unless otherwise noted.)

Parameter	Conditions	Min	Typ	Max	Unit
Input Voltage Range		3.5		18	V
OVP Threshold			19		V
UVLO Threshold		3.0			V
Supply Current in Operation	V _{EN} =2.0V, No Load		400	600	µA
Supply Current in Shutdown	V _{EN} =0		2		µA
Regulated Feedback Voltage	T _A = 25°C, 3.5V ≤ V _{IN} ≤ 18V	0.784	0.8	0.816	V
High-Side Switch On-Resistance			120		mΩ
Low-Side Switch On-Resistance			70		mΩ
High-Side Switch Leakage Current	V _{EN} =0V, V _{LX} =0V		0	10	µA
Upper Switch Current Limit	Minimum Duty Cycle		3.0		A
Oscillation Frequency	V _{FB} =0.8V		600		kHz
Maximum Duty Cycle	V _{FB} =0.8V		95		%
EN High-Level Input Voltage		1.50			V
EN Low-Level Input Voltage				0.30	V
Soft Start time			800		µs
Minimum On-Time			100		ns
Thermal Shutdown Threshold (Note 4)			160		°C
Thermal Shutdown Hysteresis (Note 4)			30		°C

Note 1: Absolute Maximum Ratings are those values beyond which the life of a device may be impaired.

Note 2: T_J is calculated from the ambient temperature T_A and power dissipation P_D according to the following formula: $T_J = T_A + P_D \times \theta_{JA}$. The maximum allowable continuous power dissipation at any ambient temperature is calculated by $P_{D(MAX)} = (T_{J(MAX)} - T_A) / \theta_{JA}$.

Note 3: Measured on JESD51-7, 4-layer PCB.

Note 4: Thermal shutdown threshold and hysteresis are guaranteed by design.

OPERATION

Internal Regulator

The TPS562201DDCR is a current mode step down DC/DC converter that provides excellent transient response with no extra external compensation components. This device contains an internal, low resistance, high voltage power MOSFET, and operates at a high 600kHz operating frequency to ensure a compact, high efficiency design with excellent AC and DC performance.

Error Amplifier

The error amplifier compares the FB pin voltage with the internal FB reference (V_{FB}) and outputs a current proportional to the difference between the two. This output current is then used to charge or discharge the internal compensation network to form the COMP voltage, which is used to control the power MOSFET current. The optimized internal compensation network minimizes the external component counts and simplifies the control loop design.

Internal Soft-Start

The soft-start is implemented to prevent the converter output voltage from overshooting during startup. When the chip starts, the internal circuitry generates a soft-start voltage (SS) ramping up from 0V to 0.8V. When it is lower than the internal reference (V_{REF}), SS overrides REF so the error amplifier uses SS as the reference. When SS is higher than REF, REF regains control. The SS time is internally fixed to 800 μ s.

Over-Current-Protection and Hiccup

The TPS562201DDCR has cycle-by-cycle over current limit when the inductor current peak value exceeds the set current limit threshold. Meanwhile, output voltage starts to drop until FB is below the Under-Voltage (UV) threshold, typically 55% below the reference. Once a UV is triggered, the TPS562201DDCR enters hiccup mode to periodically restart the part. This protection mode is especially useful when the output is dead-short to ground. The average short circuit current is greatly reduced to alleviate the thermal issue and to protect the regulator. The TPS562201DDCR exits the hiccup mode once the over current condition is removed.

Startup and Shutdown

If both VIN and EN are higher than their appropriate thresholds, the chip starts. The reference block starts first, generating stable reference voltage and currents, and then the internal regulator is enabled. The regulator provides stable supply for the remaining circuitries. Three events can shut down the chip: EN low, VIN low and thermal shutdown. In the shutdown procedure, the signaling path is first blocked to avoid any fault triggering. The COMP voltage and the internal supply rail are then pulled down. The floating driver is not subject to this shutdown command.

FUNCTIONAL BLOCK DIAGRAM

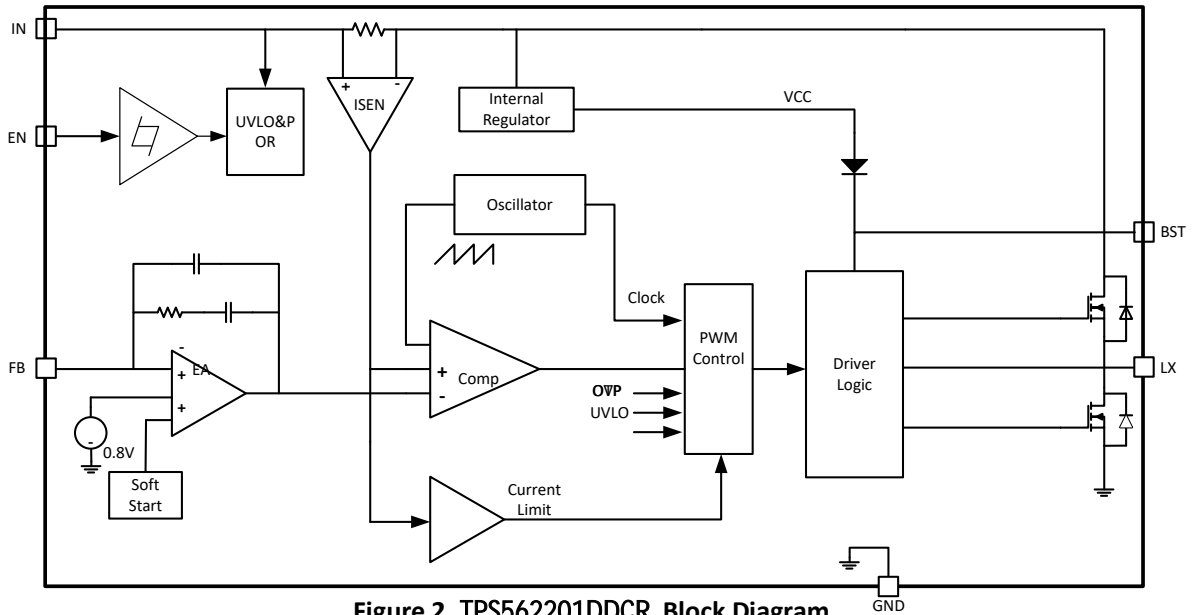

Figure 2. TPS562201DDCR Block Diagram

TYPICAL PERFORMANCE CHARACTERISTICS

Test condition: $V_{IN}=12V$, $V_{OUT}=3.3V$, $L=4.7\mu H$, $T_A=+25^\circ C$, unless other noted.

Efficiency at $V_{OUT} = 3.3V$

$V_{OUT} = 3.3V$, $L=4.7\mu H$, $DCR=30m\Omega$

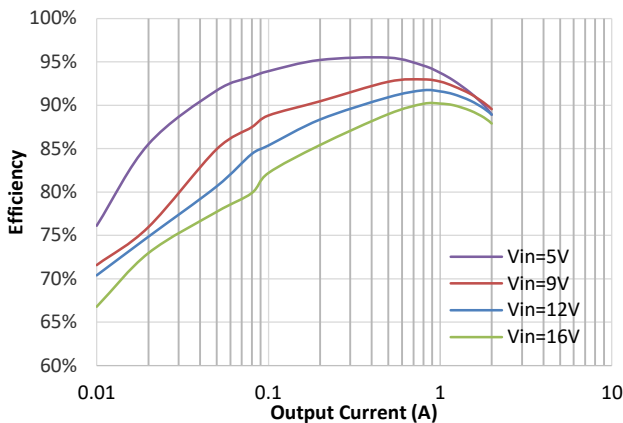

Efficiency at $V_{OUT} = 5V$

$V_{OUT} = 5V$, $L=4.7\mu H$, $DCR=30m\Omega$

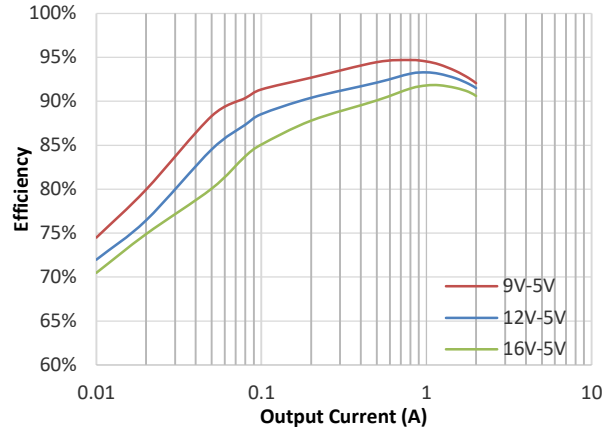

Line Regulation at $V_{OUT}=3.3V$

$V_{OUT}=3.3V$, $T_A=25^\circ C$

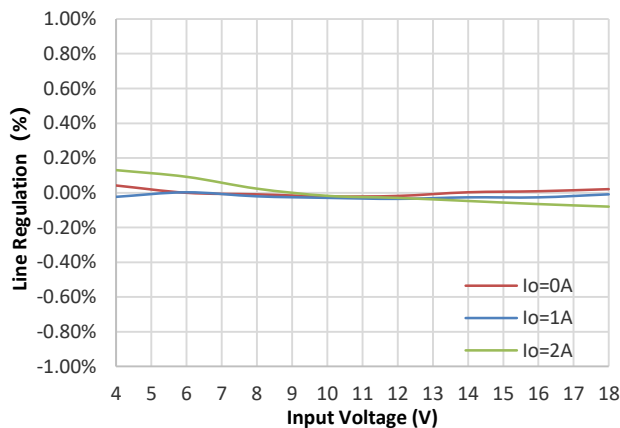

Load Regulation at $V_{IN} = 12V$

$V_{IN}=12V$, $T_A=25^\circ C$

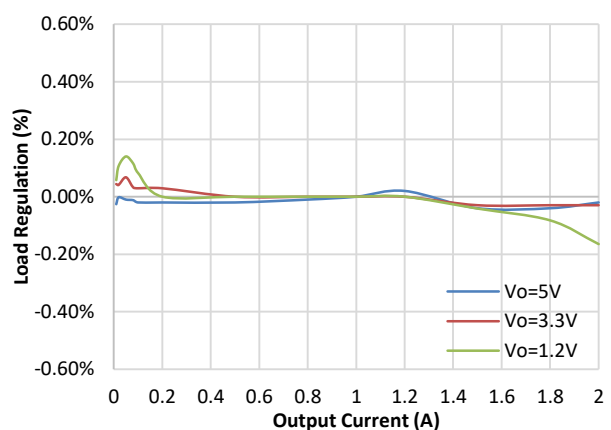

Steady State Operation

$V_{IN} = 12V$, $V_{OUT} = 3.3V$, No Load

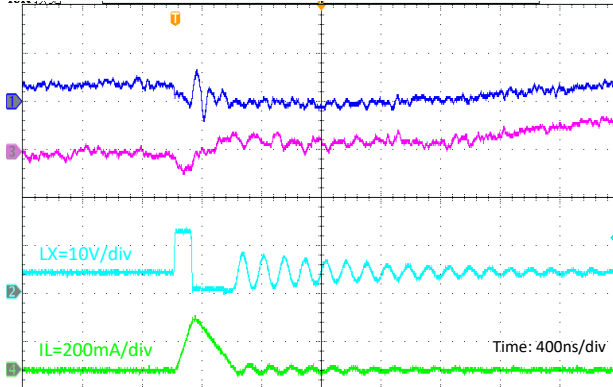

Steady State Operation

$V_{IN} = 12V$, $V_{OUT} = 3.3V$, $I_o = 2A$

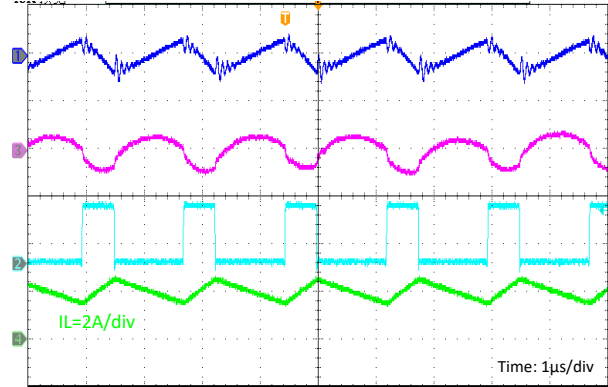

TYPICAL PERFORMANCE CHARACTERISTICS (continued)

Load Transient

$V_{IN} = 12V$, $V_{OUT} = 3.3V$, $I_o = 0.5A$ to $1.5A$

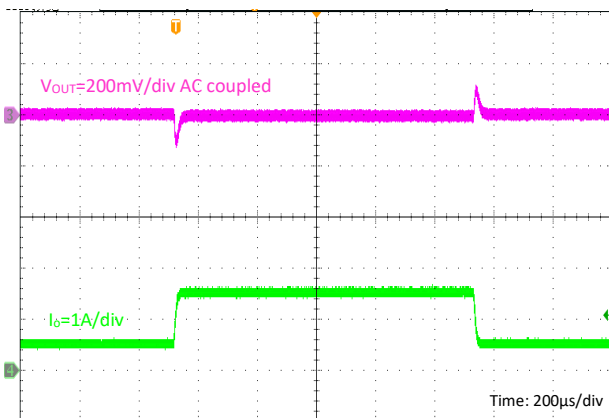

Load Transient

$V_{IN} = 12V$, $V_{OUT} = 3.3V$, $I_o = 1.0A$ to $2A$

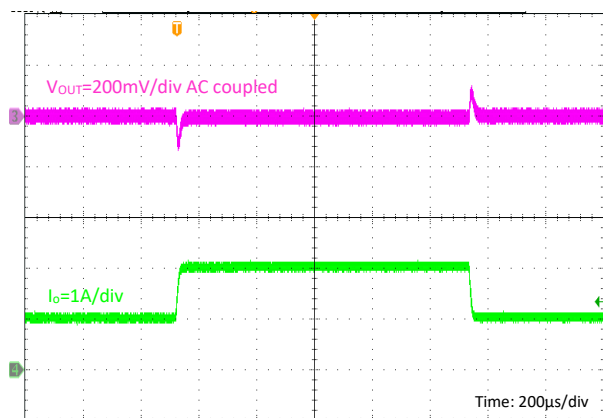

Input Power On

$V_{IN} = 12V$, $V_{OUT} = 3.3V$, No Load

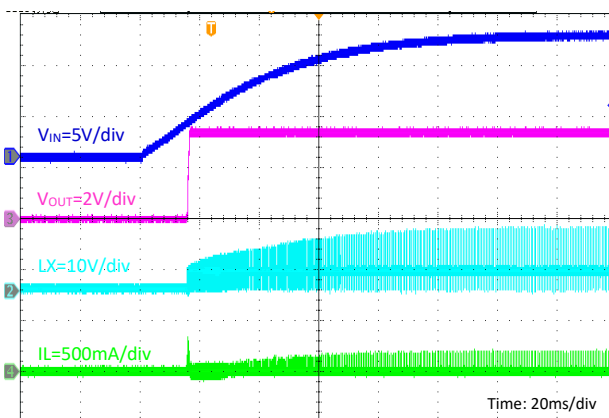

Input Power Down

$V_{IN} = 12V$, $V_{OUT} = 3.3V$, No Load

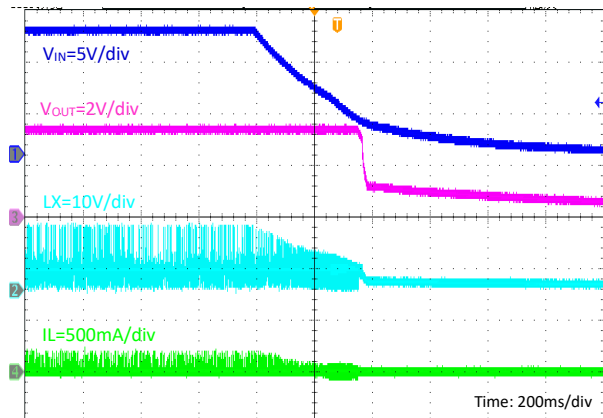

EN Enable Power On

$V_{IN} = 12V, V_{OUT} = 3.3V, I_o = 2A$

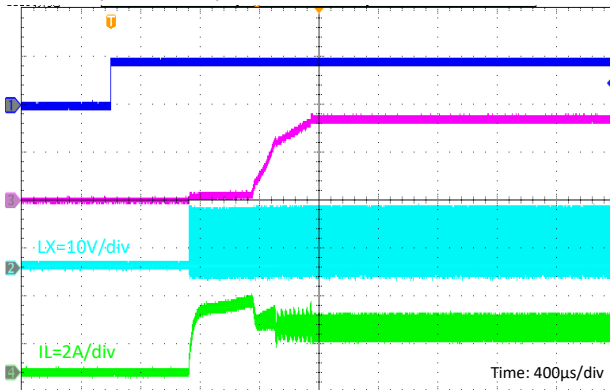

EN Disable Power down

$V_{IN} = 12V, V_{OUT} = 3.3V, I_o = 2A$

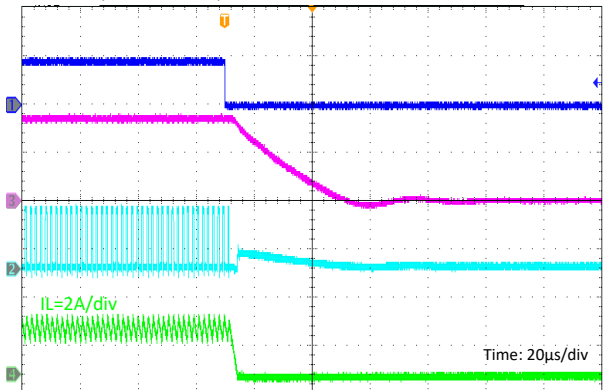

TYPICAL PERFORMANCE CHARACTERISTICS (continued)

EN Enable Power On

$V_{IN} = 12V, V_{OUT} = 3.3V, \text{No Load}$

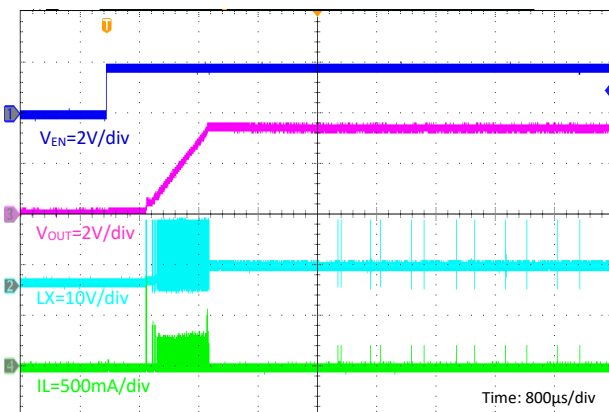

EN Disable Power down

$V_{IN} = 12V, V_{OUT} = 3.3V, \text{No Load}$

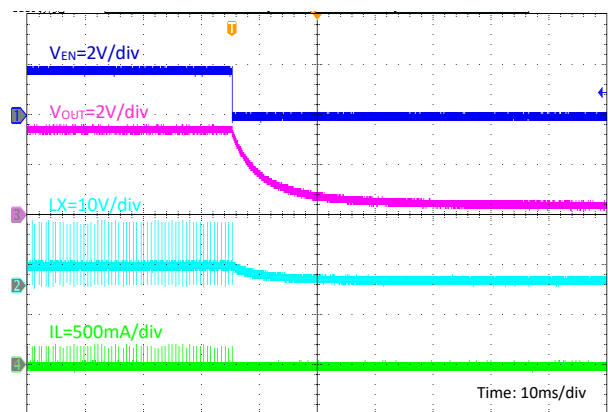

APPLICATION INFORMATION

Setting the Output Voltage

The external resistor divider is used to set the output voltage (see Typical Application on page 1). The feedback resistor R1 also sets the feedback loop bandwidth with the internal compensation capacitor. Choose R1 to be around 10kΩ for optimal transient response. R2 is then given by:

$$R_2 = \frac{R_1}{V_{out} / V_{FB} - 1}$$

Use a T-type network for when VOUT is low.

Vout	R1(kΩ)	R2(kΩ)	RT(kΩ)
5V	40.2	7.26	75
3.3V	40.2	12.13	75
2.5V	40.2	17.73	100
1.8V	40.2	29.71	120
1.2V	20.5	36.05	249
1.05V	10	26.84	300

Inductor Selection

A DC current rating of at least 25% percent higher than the maximum load current is recommended for most applications. Inductance value is related to inductor ripple current value, input voltage, output voltage setting and switching frequency. The inductor value can be derived from the following equation:

$$L = \frac{V_{OUT} \times (V_{IN} - V_{OUT})}{V_{IN} \times \Delta I_L \times f_{OSC}}$$

Where ΔI_L is inductor ripple current. Large value inductors result in lower ripple current and small value inductors result in high ripple current, so inductor value has effect on output voltage ripple value. DC resistance of inductor which has impact on efficiency of DC/DC converter should be taken into account when selecting the inductor. The maximum inductor peak current is:

$$I_{L(MAX)} = I_{LOAD} + \frac{\Delta I_L}{2}$$

Under light load conditions below 100mA, larger inductance is recommended for improved efficiency.

Output Capacitor Selection

The output capacitor (Co1) is required to maintain the DC output voltage. Ceramic, tantalum, or low ESR electrolytic capacitors are recommended. Low ESR capacitors are preferred to keep the output voltage ripple low. The output voltage ripple can be estimated by:

$$\Delta V_{OUT} = \frac{V_{OUT}}{f_s \times L} \times \left[1 - \frac{V_{OUT}}{V_{IN}} \right] \times \left[R_{ESR} + \frac{1}{8 \times f_s \times C_2} \right]$$

Where L is the inductor value and RESR is the equivalent series resistance (ESR) value of the output capacitor. In the case of ceramic capacitors, the impedance at the switching frequency is dominated by the capacitance. The output voltage ripple is mainly caused by the capacitance. For simplification, the output voltage ripple can be estimated by:

$$\Delta V_{OUT} = \frac{V_{OUT}}{8 \times f_s^2 \times L \times C_2} \times \left[1 - \frac{V_{OUT}}{V_{IN}} \right]$$

In the case of tantalum or electrolytic capacitors, the ESR dominates the impedance at the switching frequency. For simplification, the output ripple can be approximated to:

$$\Delta V_{OUT} = \frac{V_{OUT}}{f_s \times L} \times \left[1 - \frac{V_{OUT}}{V_{IN}} \right] \times R_{ESR}$$

The characteristics of the output capacitor also affect the stability of the regulation system. The TPS562201DDCR can be optimized for a wide range of capacitance and ESR values.

Layout Consideration

PCB layout is very important to achieve stable operation. It is highly recommended to duplicate EVB layout for optimum performance. If change is necessary, please follow these guidelines for reference.

- 1) Keep the path of switching current short and minimize the loop area formed by Input capacitor, high-side MOSFET and low-side MOSFET.
- 2) Bypass ceramic capacitors are suggested to be put close to the Vin Pin.
- 3) Ensure all feedback connections are short and direct. Place the feedback resistors and compensation components as close to the chip as possible.
- 4) VOUT, LX away from sensitive analog areas such as FB.
- 5) Connect IN, LX, and especially GND respectively to a large copper area to cool the chip to improve thermal performance and long-term reliability.

PACKAGE INFORMATION

SOT23-6

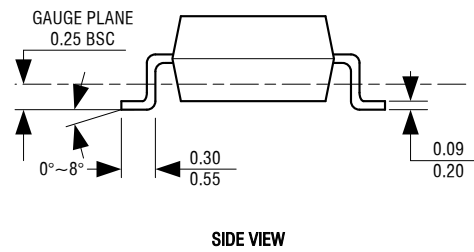
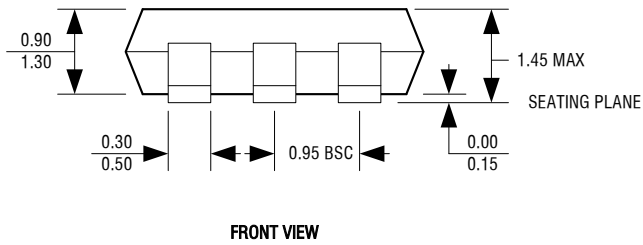
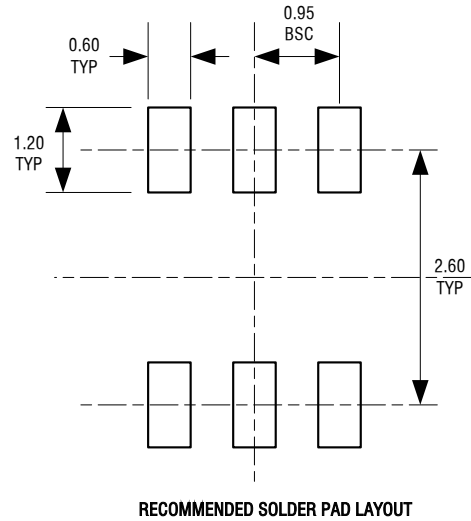
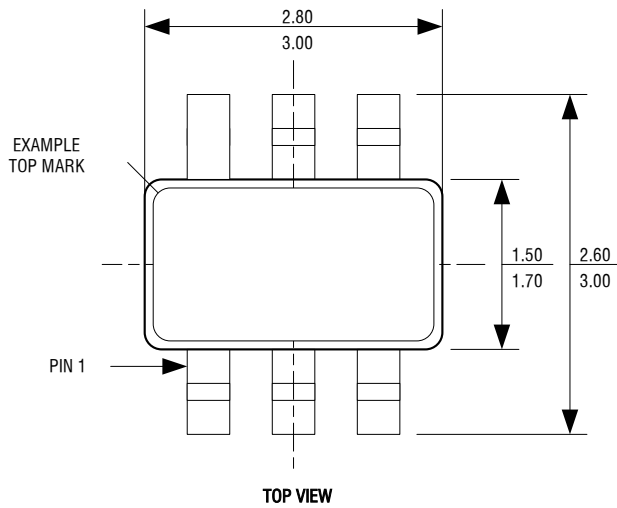

- NOTE:**
1. DIMENSIONS ARE IN MILLIMETERS.
 2. DRAWING NOT TO SCALE.
 3. DIMENSIONS ARE INCLUSIVE OF PLATING.
 4. DIMENSIONS ARE EXCLUSIVE OF MOLD FLASH AND METAL BURR.