

TLV320AIC3109-Q1 Automotive, Low-Power, 96-kHz, Mono Audio Codec

1 Features

- Qualified for Automotive Applications
- AEC-Q100 Qualified With the Following Results:
 - Temperature Grade 2: –40°C to +105°C
 - HBM ESD Classification 2
 - CDM ESD Classification C4B
- Mono Audio DAC:
 - 102-dBA Signal-to-Noise Ratio
 - Supports Sample Rates From 8 kHz to 96 kHz
 - 3D, Bass, Treble, EQ, or De-Emphasis Effects
- Mono Audio ADC:
 - 92-dBA Signal-to-Noise Ratio
 - Supports Sample Rates From 8 kHz to 96 kHz
 - Digital Signal Processing and Noise Filtering
- Four Audio Input Pins:
 - Up to Two Differential Inputs
 - Up to Two Single-Ended Inputs
- Six Audio Output Drivers:
 - One Fully Differential or Two Single-Ended Headphone Drivers
 - Mono Pair of Fully-Differential Line Outputs
- Low Power: 14-mW Mono, 48-kHz Playback With 3.3-V Analog Supply
- Ultra-Low Power Mode With Passive Analog Bypass
- Front-End Programmable Gain Amplifier (PGA)
- Programmable Digital Gain for DAC Playback
- Automatic Gain Control (AGC) for Record
- Programmable Microphone Bias
- Programmable PLL for Flexible Clock Generation
- I²C Control Bus
- Audio Data Formats: I²S, Left- and Right-Justified, DSP, and TDM
- Power Supplies:
 - Analog (AVDD, DRVDD): 2.7 V to 3.6 V
 - Digital Core (DVDD): 1.525 V to 1.95 V
 - Digital I/O (IOVDD): 1.1 V to 3.6 V
- Available in Two VQFN-32 Package Options:
 - Non-Wettable (6PAIC3109TRHBRQ1)
 - Wettable-Flank (6PAIC3109TWRHMRQ1)

2 Applications

- Emergency Call (eCall) Systems
- Telematics Control Unit (TCU)
- Automotive Head Units

3 Description

The TLV320AIC3109-Q1 device is a low-power mono audio codec with a mono headphone amplifier and multiple input and output channels that are programmable in single-ended or fully differential configurations. The device includes extensive register-based power control, allowing 48-kHz digital-to-analog converter (DAC) playback at as little as 14-mW consumption, making the device well-suited for low-power applications.

The record path of the TLV320AIC3109-Q1 contains integrated microphone bias, a digitally controlled microphone preamplifier, automatic gain control (AGC), a flexible front-end multiplexer (MUX), and a front-end analog mixer (MIX). During record, programmable filters can remove audible noise. The playback path includes MIX and MUX capability from the mono DAC and selected inputs, through programmable volume controls, to the various outputs.

Device Information⁽¹⁾

PART NUMBER	PACKAGE	BODY SIZE (NOM)
TLV320AIC3109-Q1	VQFN (32)	5.00 mm x 5.00 mm

(1) For all available packages, see the orderable addendum at the end of the datasheet.

Simplified Diagram

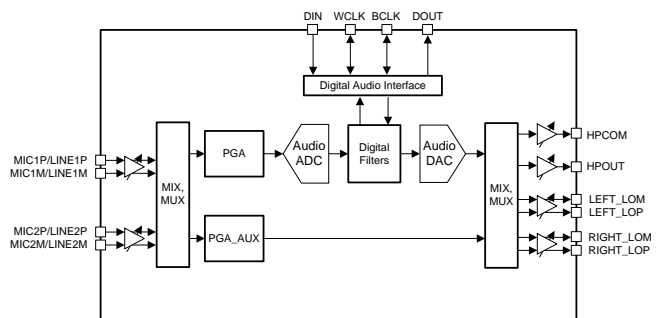

Table of Contents

1 Features	1	7.5 Programming.....	38
2 Applications	1	7.6 Register Maps	40
3 Description	1	8 Application and Implementation	104
4 Revision History	2	8.1 Application Information.....	104
5 Pin Configuration and Functions	3	8.2 Typical Application	104
6 Specifications	4	9 Power Supply Recommendations	107
6.1 Absolute Maximum Ratings	4	10 Layout	107
6.2 ESD Ratings.....	4	10.1 Layout Guidelines	107
6.3 Recommended Operating Conditions.....	5	10.2 Layout Example	108
6.4 Thermal Information	5	11 Device and Documentation Support	109
6.5 Electrical Characteristics.....	6	11.1 Documentation Support	109
6.6 Audio Data Serial Interface Timing Requirements..	10	11.2 Receiving Notification of Documentation Updates.....	109
6.7 Typical Characteristics	14	11.3 Community Resources.....	109
7 Detailed Description	16	11.4 Trademarks	109
7.1 Overview	16	11.5 Electrostatic Discharge Caution.....	109
7.2 Functional Block Diagram	16	11.6 Glossary	109
7.3 Feature Description.....	17	12 Mechanical, Packaging, and Orderable Information	109
7.4 Device Functional Modes.....	35		

4 Revision History

NOTE: Page numbers for previous revisions may differ from page numbers in the current version.

Changes from Original (August 2017) to Revision A	Page
• Released 6PAIC3109TWRHMRQ1 (wetttable-flank package option) to production.....	1
• Added TI Design to document.....	1

5 Pin Configuration and Functions

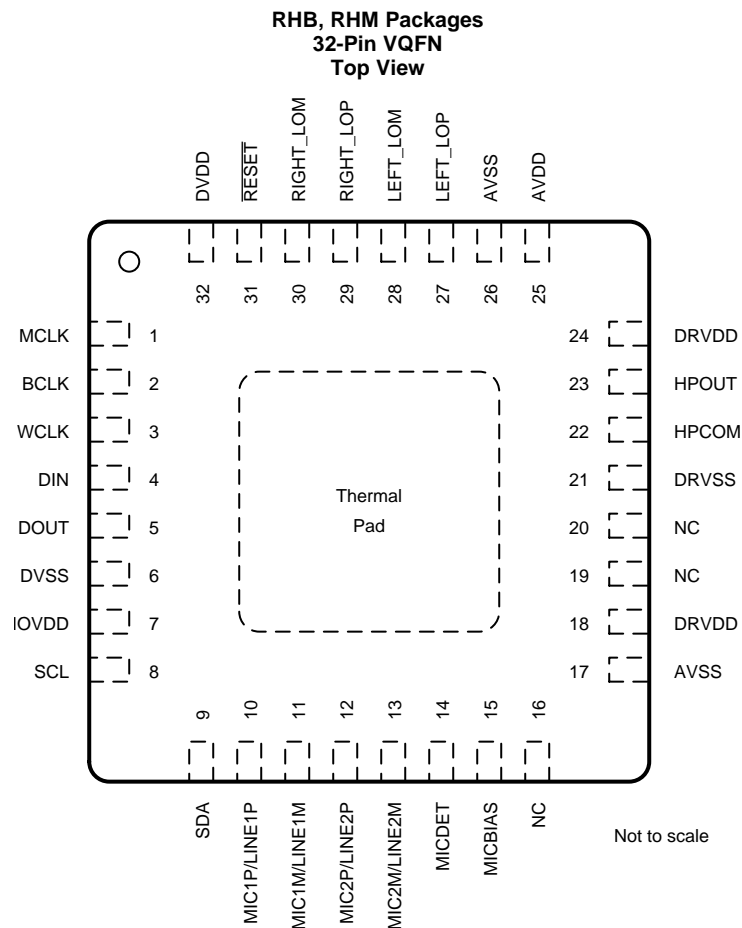

NOTE: Connect the device thermal pad to DRVSS.

Pin Functions

PIN		TYPE	DESCRIPTION
NAME	NO.		
AVDD	25	—	Analog DAC voltage supply; connect 1- μ F and 0.1- μ F decoupling capacitors in parallel to AVSS
AVSS	17, 26	—	Analog ground
BCLK	2	Digital I/O	Audio serial data bus bit clock input/output
DIN	4	Digital input	Audio serial data bus data input
DOUT	5	Digital output	Audio serial data bus data output
DRVDD	18, 24	—	Analog ADC and output driver voltage supply; connect 1- μ F and 0.1- μ F decoupling capacitors in parallel to DRVSS
DRVSS	21	—	Analog output driver ground supply
DVDD	32	—	Digital core voltage supply; connect 1- μ F and 0.1- μ F decoupling capacitors in parallel to DVSS
DVSS	6	—	Digital core and I/O ground supply
HPCOM	22	Analog output	High-power output driver (single-ended output, differential output (–), or VCM output)
HPOUT	23	Analog output	High-power output driver, single-ended output or differential output (+)
IOVDD	7	—	Digital I/O voltage supply
LEFT_LOM	28	Analog output	Left line output (–); leave floating when not used
LEFT_LOP	27	Analog output	Left line output (+); leave floating when not used

Pin Functions (continued)

PIN		TYPE	DESCRIPTION
NAME	NO.		
MCLK	1	Digital input	Master clock input
MIC1M/LINE1M	11	Analog input	Microphone or line input, differential only (-); connect a 0.47- μ F capacitor to AVSS when not used
MIC1P/LINE1P	10	Analog input	Microphone or line input, differential (+) or single-ended; connect a 0.47- μ F capacitor to AVSS when not used
MIC2M/LINE2M	13	Analog input	Microphone or line input, differential only (-); connect a 0.47- μ F capacitor to AVSS when not used
MIC2P/LINE2P	12	Analog input	Microphone or line input, differential (+) or single-ended; connect a 0.47- μ F capacitor to AVSS when not used
MICDET	14	Analog input	Microphone detection input; leave floating when not used
NC	16, 19, 20	—	Not connected; always leave floating
MICBIAS	15	Analog output	Microphone bias voltage output; leave floating when not used
RESET	31	Digital input	Reset
RIGHT_LOM	30	Analog output	Right line output (-); leave floating when not used
RIGHT_LOP	29	Analog output	Right line output (+); leave floating when not used
SCL	8	Digital I/O	I ² C serial clock input
SDA	9	Digital I/O	I ² C serial data input/output
WCLK	3	Digital I/O	Audio serial data bus word clock input/output

6 Specifications

6.1 Absolute Maximum Ratings

		MIN	MAX	UNIT
Power-supply voltage	AVDD to AVSS, DRVDD to DRVSS	-0.3	3.9	V
	AVDD to DRVSS	-0.3	3.9	
	IOVDD to DVSS	-0.3	3.9	
	DVDD to DVSS	-0.3	2.5	
	AVDD to DRVDD	-0.1	0.1	
Analog input voltage	Analog input voltage to AVSS	-0.3	AVDD + 0.3	V
Digital input voltage	Digital input voltage to DVSS	-0.3	IOVDD + 0.3	V
Temperature	Operating ambient, T _A	-40	105	°C
	Junction, T _J	-40	125	
	Storage, T _{stg}	-40	150	

- Stresses beyond those listed under *Absolute Maximum Ratings* may cause permanent damage to the device. These are stress ratings only, which do not imply functional operation of the device at these or any other conditions beyond those indicated under *Recommended Operating Conditions*. Exposure to absolute-maximum-rated conditions for extended periods may affect device reliability.
- ESD compliance tested to EIA/JESD22-A114-B and passed.

6.2 ESD Ratings

			VALUE	UNIT	
V _(ESD)	Electrostatic discharge	Human-body model (HBM), per AEC Q100-002 ⁽¹⁾	±2000	V	
		Charged-device model (CDM), per AEC Q100-011	Corner pins (1, 8, 9, 16, 17, 24, 25, 32)		±750
			All other pins		±500

- AEC Q100-002 indicates that HBM stressing shall be in accordance with the ANSI/ESDA/JEDEC JS-001 specification.

6.3 Recommended Operating Conditions

		MIN	NOM	MAX	UNIT
POWER SUPPLY					
	Analog supply voltage (AVDD to AVSS, DRVDD to DRVSS)	2.7	3.3	3.6	V
	Digital core supply voltage (DVDD to DVSS)	1.525	1.8	1.95	V
	Digital I/O supply voltage (IOVDD to DVSS)	1.1	1.8	3.6	V
ANALOG INPUTS					
V _I	Analog full-scale, 0-dB input voltage (DRVDD = 3.3 V)	0.707			V _{RMS}
DIGITAL INPUTS					
V _{DIG}	Digital input voltage	DVSS		IOVDD	V
TEMPERATURE					
T _A	Operating free-air temperature	-40		105	°C
OTHERS					
	Mono line output load resistance	10			kΩ
	Mono headphone output load resistance	16			Ω
	Digital output load capacitance		10		pF

6.4 Thermal Information

THERMAL METRIC ⁽¹⁾		TLV320AIC3109-Q1		UNIT
		RHB (VQFN)	RHM (VQFN)	
		32 PINS	32 PINS	
R _{θJA}	Junction-to-ambient thermal resistance	31.1	31.3	°C/W
R _{θJC(top)}	Junction-to-case (top) thermal resistance	19.5	18.9	°C/W
R _{θJB}	Junction-to-board thermal resistance	10.6	11.1	°C/W
ψ _{JT}	Junction-to-top characterization parameter	0.2	0.2	°C/W
ψ _{JB}	Junction-to-board characterization parameter	10.6	11.1	°C/W
R _{θJC(bot)}	Junction-to-case (bottom) thermal resistance	0.9	0.9	°C/W

- (1) For more information about traditional and new thermal metrics, see the [Semiconductor and IC Package Thermal Metrics](#) application report.

6.5 Electrical Characteristics

 at 25°C, AVDD = DRVDD = IOVDD = 3.3 V, DVDD = 1.8 V, $f_S = 48$ kHz, and 16-bit audio data (unless otherwise noted)

PARAMETER		TEST CONDITIONS	MIN	TYP	MAX	UNIT
AUDIO ADC						
	Input signal level	Single-ended configurations		0.707		V_{RMS}
SNR	Signal-to-noise ratio ⁽¹⁾⁽²⁾	A-weighted, $f_S = 48$ kSPS, 0-dB PGA gain, inputs ac-shortened to ground	80	92		dB
DR	Dynamic range ⁽¹⁾⁽²⁾	$f_S = 48$ kSPS; 0-dB PGA gain; 1-kHz, –60-dB, full-scale input signal		93		dB
THD	Total harmonic distortion	$f_S = 48$ kSPS; 0-dB PGA gain; 1-kHz, –2-dB, full-scale input signal		–89	–75	dB
PSRR	Power-supply rejection ratio	217-Hz signal applied to DRVDD		55		dB
		1-kHz signal applied to DRVDD		44		
	Input channel separation	1-kHz, –2-dB, full-scale signal, MIC1 to MIC2		–71		dB
	Gain error	$f_S = 48$ kSPS; 0-dB PGA gain; 1-kHz, –2-dB, full-scale input signal		0.82		dB
	ADC programmable-gain amplifier maximum gain	1-kHz input tone		59.5		dB
	ADC programmable-gain amplifier step size			0.5		dB
	Input resistance	MIC1/MIC2 inputs routed to single ADC input MIX attenuation = 0 dB		20		k Ω
		MIC1/MIC2 inputs routed to single ADC input MIX attenuation = 12 dB		80		
	Input resistance			80		k Ω
	Input capacitance	MIC1/LINE1 inputs		10		pF
	Input level control minimum attenuation setting			0		dB
	Input level control maximum attenuation setting			12		dB
	Input level control attenuation step size			1.5		dB
ANALOG PASSTHROUGH MODE						
$R_{DS(on)}$	Input-to-output switch resistance	MIC1/LINE1 to LINEOUT		330		Ω
INPUT SIGNAL LEVEL, DIFFERENTIAL						
SNR	Signal-to-noise ratio	A-weighted, $f_S = 48$ kSPS, 0-dB PGA gain, inputs ac-shortened to ground		92		dB
THD	Total harmonic distortion	$f_S = 48$ kHz; 0-dB PGA gain, 1-kHz, –2-dB, full-scale input signal		–94		dB
ADC DIGITAL DECIMATION FILTER ($f_S = 48$ kHz)						
	Filter gain	From 0 f_S to 0.39 f_S		± 0.1		dB
		At 0.4125 f_S		–0.25		
		At 0.45 f_S		–3		
		At 0.5 f_S		–17.5		
		From 0.55 f_S to 64 f_S		–75		
	Filter group delay			$17/f_S$		s

- (1) Ratio of output level with 1-kHz, full-scale, sine-wave input to the output level with the inputs short-circuited, measured A-weighted over a 20-Hz to 20-kHz bandwidth using an audio analyzer.
- (2) All performance measurements done with 20-kHz, low-pass filter and an A-weighted filter, where noted. Failure to use such a filter may result in higher THD+N and lower SNR and dynamic range readings than shown in the *Electrical Characteristics*. The low-pass filter removes out-of-band noise, which, although not audible, may affect dynamic specification values.

Electrical Characteristics (continued)

at 25°C, AVDD = DRVDD = IOVDD = 3.3 V, DVDD = 1.8 V, $f_S = 48$ kHz, and 16-bit audio data (unless otherwise noted)

PARAMETER		TEST CONDITIONS	MIN	TYP	MAX	UNIT	
MICROPHONE BIAS							
Bias voltage	Programmable setting = 2 V		2		V		
	Programmable setting = 2.5 V		2.3	2.455			2.7
	Programmable setting = AVDD		AVDD				
Current sourcing	Programmable setting = 2.5 V		4			mA	
AUDIO DAC, DIFFERENTIAL LINE OUTPUT ($R_{LOAD} = 10$ kΩ)							
Full-scale output voltage	0-dB input full-scale signal, output common-mode setting = 1.35 V, output volume control = 0 dB		1.414			V_{RMS}	
			4			V_{PP}	
SNR	Signal-to-noise ratio ⁽³⁾	A-weighted, $f_S = 48$ kHz, output volume control = 0 dB, no input signal, referenced to full-scale input level	88	102		dB	
DR	Dynamic range	A-weighted, $f_S = 48$ kHz, –60-dB input full-scale signal, output volume control = 0 dB, output common-mode setting = 1.35 V		97		dB	
THD	Total harmonic distortion	$f_S = 48$ kHz; 0-dB, 1-kHz input full-scale signal; output volume control = 0 dB; output common-mode setting = 1.35 V		–95	–75	dB	
PSRR	Power-supply rejection ratio	217-Hz signal applied to DRVDD, AVDD		78		dB	
		1-kHz signal applied to DRVDD, AVDD		80			
DAC gain error		0-dB, 1-kHz input full-scale signal; output volume control = 0 dB; output common-mode setting = 1.35 V; $f_S = 48$ kHz		–0.2		dB	
AUDIO DAC, SINGLE-ENDED LINE OUTPUT ($R_{LOAD} = 10$ kΩ)							
Full-scale output voltage		0-dB input full-scale signal, output common-mode setting = 1.35 V, output volume control = 0 dB		0.707		V_{RMS}	
SNR	Signal-to-noise ratio	A-weighted, $f_S = 48$ kHz, output volume control = 0 dB, no input signal, referenced to full-scale input level		96		dB	
		A-weighted, $f_S = 48$ kHz, output volume control = 0 dB, no input signal, referenced to full-scale input level, 50% DAC current-boost mode		97			
DR	Dynamic range	A-weighted, $f_S = 48$ kHz, –60-dB input full-scale signal, output volume control = 0 dB, output common-mode setting = 1.35 V		91		dB	
DAC gain error		0-dB, 1-kHz input full-scale signal; output volume control = 0 dB; output common-mode setting = 1.35 V; $f_S = 48$ kHz		–0.85		dB	

(3) Unless otherwise noted, all measurements use an output common-mode voltage setting of 1.35 V, a 0-dB output level control gain, and a 16- Ω single-ended load.

Electrical Characteristics (continued)

 at 25°C, AVDD = DRVDD = IOVDD = 3.3 V, DVDD = 1.8 V, $f_S = 48$ kHz, and 16-bit audio data (unless otherwise noted)

PARAMETER		TEST CONDITIONS	MIN	TYP	MAX	UNIT
AUDIO DAC, SINGLE-ENDED HEADPHONE OUTPUT ($R_{LOAD} = 16 \Omega$)						
	Full-scale output voltage	0-dB input full-scale signal, output common-mode setting = 1.35 V, output volume control = 0 dB		0.707		V_{RMS}
SNR	Signal-to-noise ratio	A-weighted, $f_S = 48$ kHz, output volume control = 0 dB, no input signal, referenced to full-scale input level		96		dB
		A-weighted, $f_S = 48$ kHz, output volume control = 0 dB, no input signal, referenced to full-scale input level, 50% DAC current-boost mode		97		
DR	Dynamic range	A-weighted, $f_S = 48$ kHz, –60-dB input full-scale signal, output volume control = 0 dB, output common-mode setting = 1.35 V		91		dB
THD	Total harmonic distortion	$f_S = 48$ kHz, 0-dB input full-scale signal, output volume control = 0 dB, output common-mode setting = 1.35 V		–71	–65	dB
PSRR	Power-supply rejection ratio	217-Hz signal applied to DRVDD, AVDD		43		dB
		1-kHz signal applied to DRVDD, AVDD		41		
	DAC gain error	0-dB, 1-kHz input full-scale signal; output volume control = 0 dB; output common-mode setting = 1.35 V; $f_S = 48$ kHz		–0.85		dB
DAC DIGITAL INTERPOLATION FILTER ($f_S = 48$ kHz)						
	Pass band		0		$0.45 f_S$	Hz
	Pass-band ripple			± 0.06		dB
	Transition band		$0.45 f_S$		$0.55 f_S$	Hz
	Stop band		$0.55 f_S$		$7.5 f_S$	Hz
	Stop-band attenuation			65		dB
	Group delay			$21 / f_S$		s
MONO HEADPHONE DRIVER (AC-Coupled Output Configuration⁽³⁾)						
	0-dB full-scale output voltage	0-dB gain to high-power outputs, output common-mode voltage setting = 1.35 V		0.707		V_{RMS}
	Programmable output common-mode voltage (applicable to line outputs also)	First option		1.35		V
		Second option		1.5		
		Third option		1.65		
		Fourth option		1.8		
	Maximum programmable output level control gain			9		dB
	Programmable output level control gain step size			1		dB
P_O	Maximum output power	$R_L = 32 \Omega$		15		mW
		$R_L = 16 \Omega$		30		
SNR	Signal-to-noise ratio ⁽⁴⁾	A-weighted		94		dB

(4) Ratio of output level with a 1-kHz, full-scale input to the output level playing an all-zero signal, measured A-weighted over a 20-Hz to 20-kHz bandwidth.

Electrical Characteristics (continued)

 at 25°C, AVDD = DRVDD = IOVDD = 3.3 V, DVDD = 1.8 V, f_S = 48 kHz, and 16-bit audio data (unless otherwise noted)

PARAMETER		TEST CONDITIONS	MIN	TYP	MAX	UNIT	
MONO HEADPHONE DRIVER (AC-Coupled Output Configuration, continued)							
THD	Total harmonic distortion	1-kHz output, P _O = 5 mW, R _L = 32 Ω		-77		dB	
				0.014%			
		1-kHz output, P _O = 10 mW, R _L = 32 Ω		-76		dB	
				0.016%			
		1-kHz output, P _O = 10 mW, R _L = 16 Ω		-73		dB	
				0.022%			
		1-kHz output, P _O = 20 mW, R _L = 16 Ω		-71		dB	
				0.028%			
	Channel separation	1-kHz, 0-dB input		90		dB	
PSRR	Power-supply rejection ratio	217 Hz, 100 mV _{PP} on AVDD, DRVDD		48		dB	
	Mute attenuation	1-kHz output		107		dB	
DIGITAL I/O							
V _{IL}	Input low level		-0.3	0.3 IOVDD		V	
V _{IH}	Input high level ⁽⁵⁾	IOVDD > 1.6 V	0.7 IOVDD			V	
		IOVDD ≤ 1.6 V	1.1				
V _{OL}	Output low level			0.1 IOVDD		V	
V _{OH}	Output high level		0.8 IOVDD			V	
CURRENT CONSUMPTION (DRVDD = AVDD = IOVDD = 3.3 V, DVDD = 1.8 V)							
I _{IN}	I _{DRVDD} + I _{AVDD}	RESET held low		0.1		μA	
	I _{DVDD}			0.2			
	I _{DRVDD} + I _{AVDD}	Mono ADC record, f _S = 8 kSPS, I ² S slave, AGC off, no signal		2.15		mA	
	I _{DVDD}			0.48			
	I _{DRVDD} + I _{AVDD}	Mono ADC record, f _S = 48 kSPS, I ² S slave, AGC off, no signal		4.31 ⁽⁶⁾			
	I _{DVDD}			2.45 ⁽⁶⁾			
	I _{DRVDD} + I _{AVDD}	Mono DAC playback to lineout, analog mixer bypassed, f _S = 48 kSPS, I ² S slave		3.5			
	I _{DVDD}			2.3			
	I _{DRVDD} + I _{AVDD}	Mono DAC playback to lineout, f _S = 48 kSPS, I ² S slave, no signal		4.9			
	I _{DVDD}			2.3			
	I _{DRVDD} + I _{AVDD}	Mono DAC playback to mono single-ended headphone, f _S = 48 kSPS, I ² S slave, no signal		6.7			
	I _{DVDD}			2.3			
	I _{DRVDD} + I _{AVDD}	Mono line in to mono line out, no signal		3.11			
	I _{DVDD}			0			
	I _{DRVDD} + I _{AVDD}	Extra power when PLL enabled		1.4			
	I _{DVDD}			0.9			
	I _{DRVDD} + I _{AVDD}	All blocks powered down, headset detection enabled, headset not inserted		28			μA
	I _{DVDD}			2			

 (5) When IOVDD < 1.6 V, minimum V_{IH} is 1.1 V.

(6) Additional power is consumed when the PLL is powered.

6.6 Audio Data Serial Interface Timing Requirements⁽¹⁾⁽²⁾

		IOVDD = 1.1 V		IOVDD = 3.3 V		UNIT
		MIN	MAX	MIN	MAX	
I²S, LEFT-JUSTIFIED AND RIGHT-JUSTIFIED TIMING IN MASTER MODE (See Figure 1)						
t _d (WS)	ADWS, WCLK delay time		50		15	ns
t _d (DO-WS)	ADWS, WCLK to DOUT delay time		50		20	ns
t _d (DO-BCLK)	BCLK to DOUT delay time		50		15	ns
t _s (DI)	DIN setup time	10		6		ns
t _h (DI)	DIN hold time	10		6		ns
t _r	Rise time		30		10	ns
t _f	Fall time		30		10	ns
DSP TIMING IN MASTER MODE (See Figure 2)						
t _d (WS)	ADWS, WCLK delay time		50		15	ns
t _d (DO-BCLK)	BCLK to DOUT delay time		50		15	ns
t _s (DI)	DIN setup time	10		6		ns
t _h (DI)	DIN hold time	10		6		ns
t _r	Rise time		30		10	ns
t _f	Fall time		30		10	ns
I²S, LEFT-JUSTIFIED AND RIGHT-JUSTIFIED TIMING IN SLAVE MODE (See Figure 3)						
t _H (BCLK)	BCLK high period	70		35		ns
t _L (BCLK)	BCLK low period	70		35		ns
t _s (WS)	ADWS, WCLK setup time	10		6		ns
t _h (WS)	ADWS, WCLK hold time	10		6		ns
t _d (DO-WS)	ADWS, WCLK to DOUT delay time (for left-justified mode only)		50		35	ns
t _d (DO-BCLK)	BCLK to DOUT delay time		50		20	ns
t _s (DI)	DIN setup time	10		6		ns
t _h (DI)	DIN hold time	10		6		ns
t _r	Rise time		8		4	ns
t _f	Fall time		8		4	ns
DSP TIMING IN SLAVE MODE (See Figure 4)						
t _H (BCLK)	BCLK high period	70		35		ns
t _L (BCLK)	BCLK low period	70		35		ns
t _s (WS)	ADWS, WCLK setup time	10		8		ns
t _h (WS)	ADWS, WCLK hold time	10		8		ns
t _d (DO-BCLK)	BCLK to DOUT delay time		50		20	ns
t _s (DI)	DIN setup time	10		6		ns
t _h (DI)	DIN hold time	10		6		ns
t _r	Rise time		8		4	ns
t _f	Fall time		8		4	ns

(1) All timing specifications are measured at characterization but not tested at final test.

(2) All specifications at 25°C, DVDD = 1.8 V.

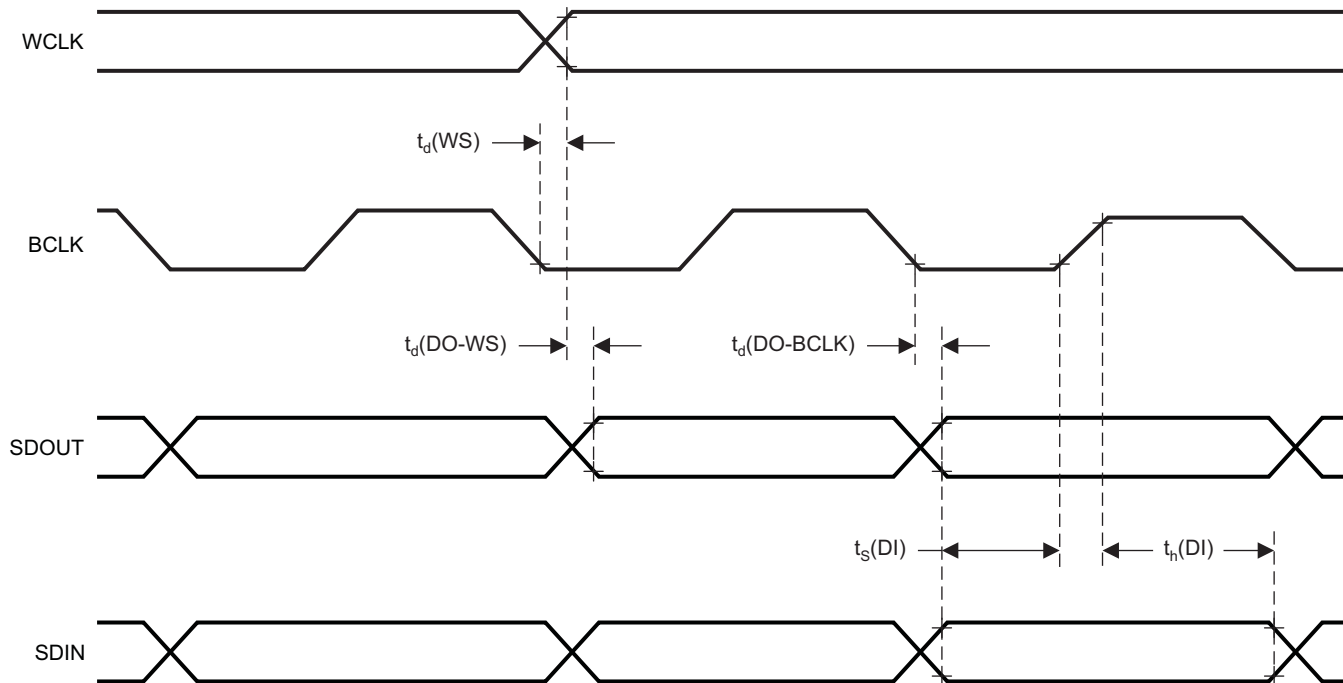

T0145-01

Figure 1. I²S, Left-Justified and Right-Justified Format Timing in Master Mode

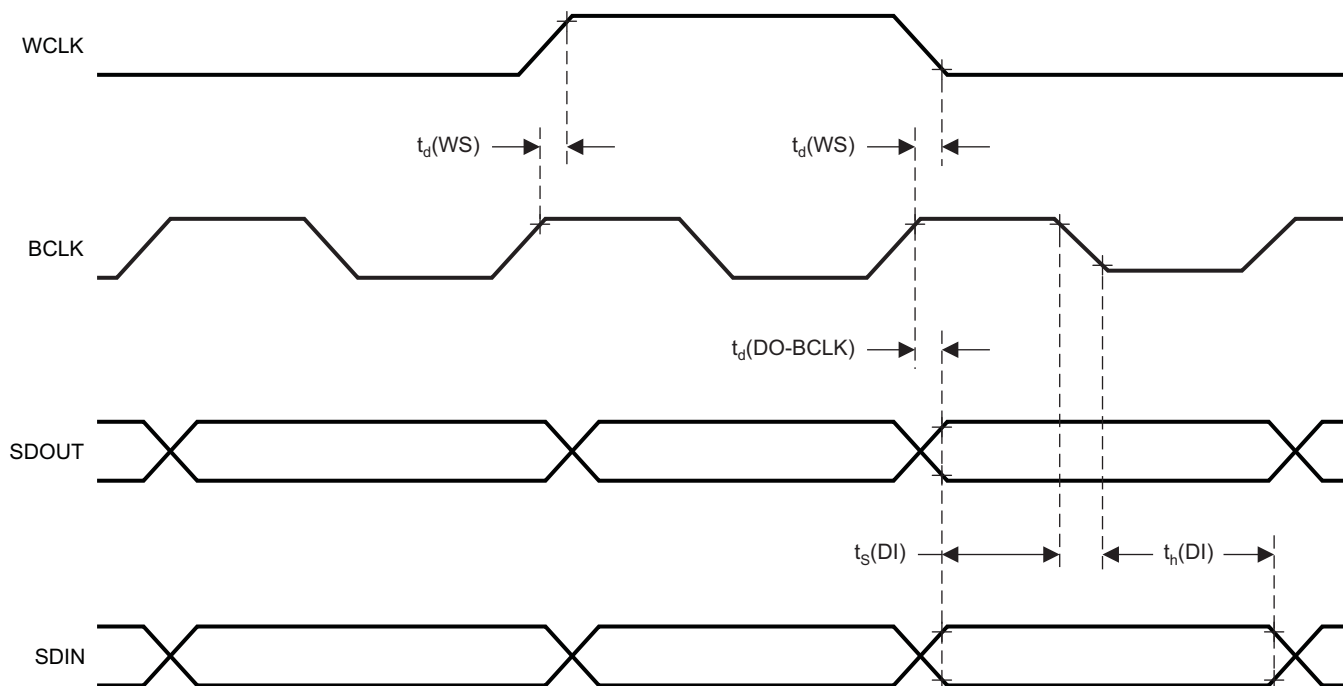

T0146-01

Figure 2. DSP Timing in Master Mode

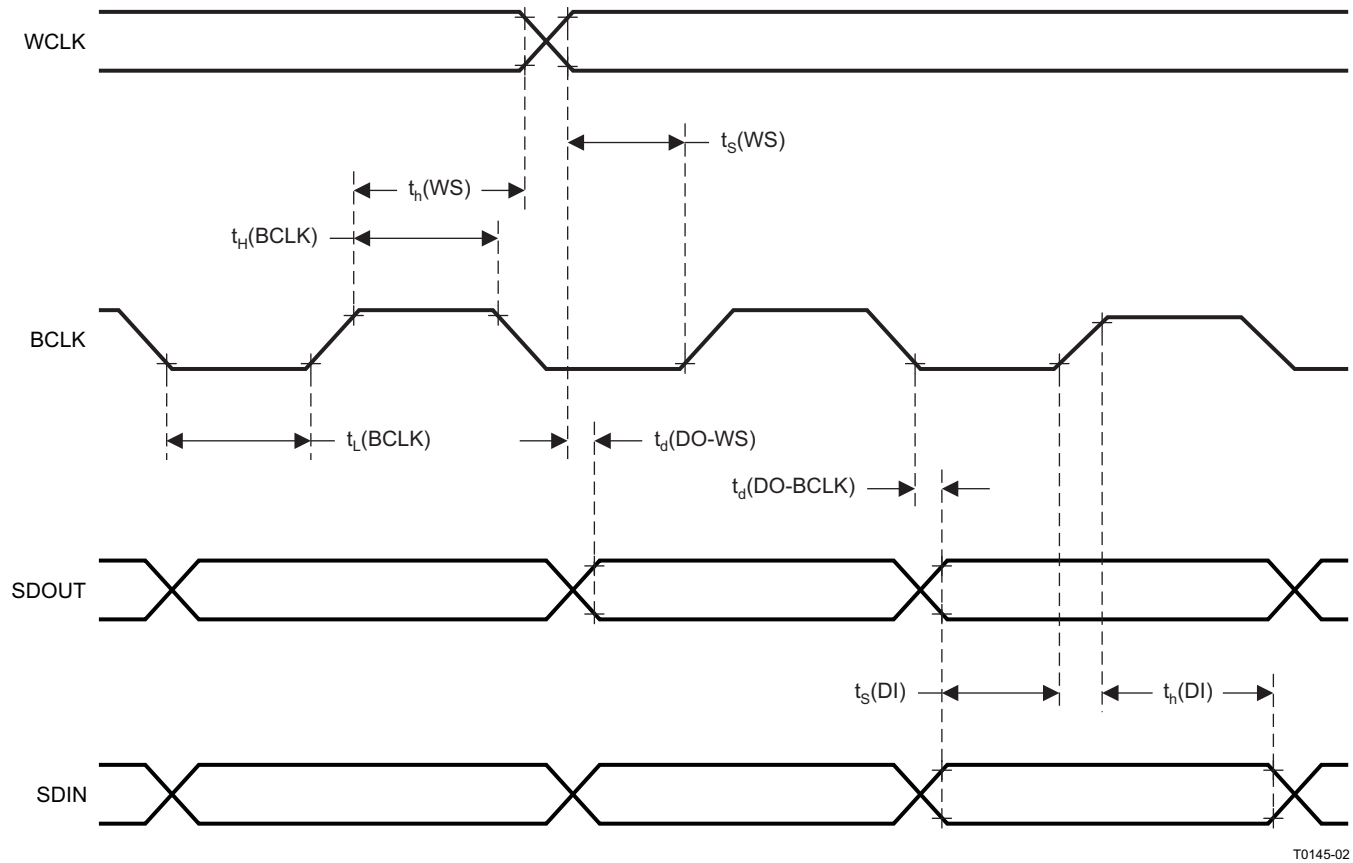
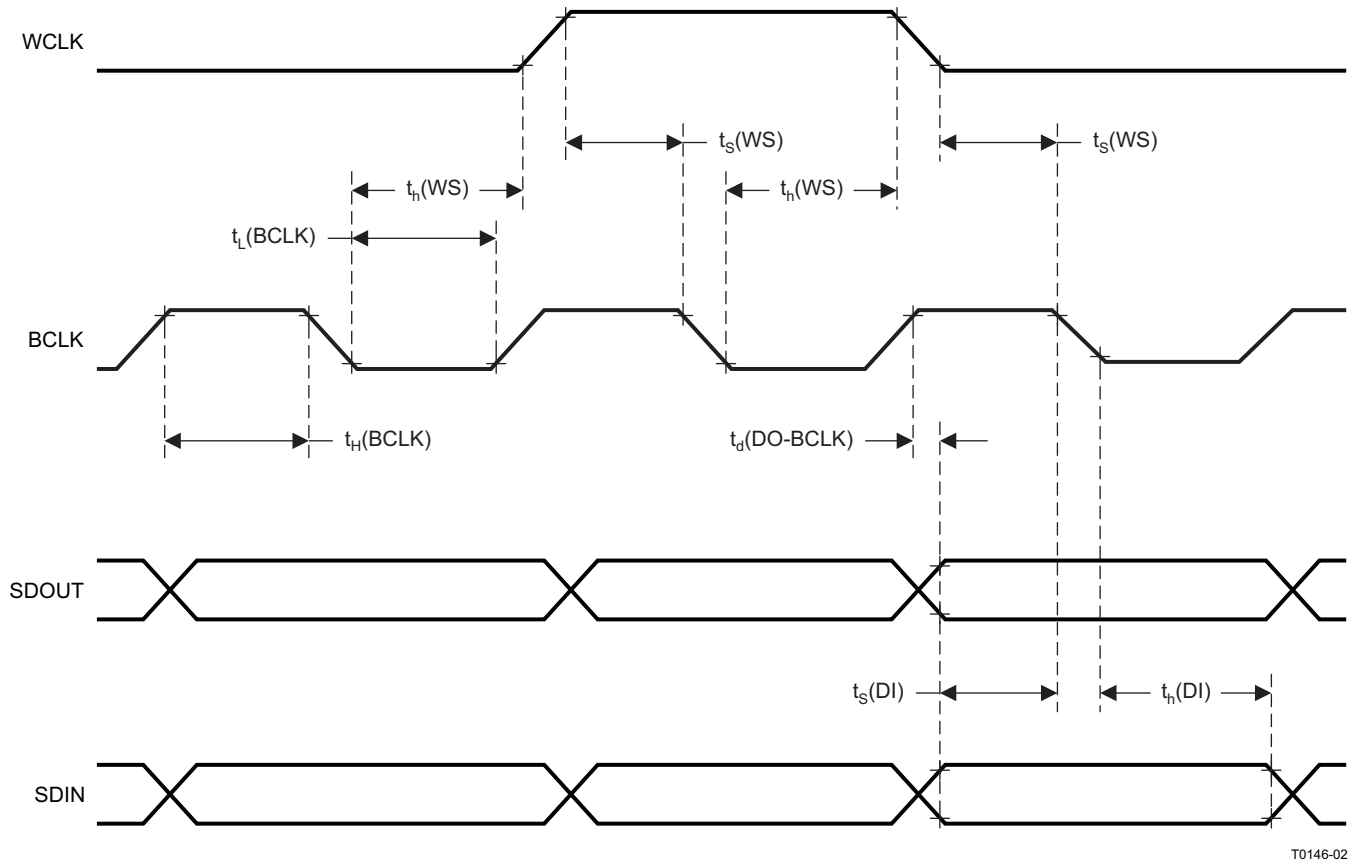

Figure 3. I²S, Left-Justified and Right-Justified Format Timing in Slave Mode



T0146-02

Figure 4. DSP Timing in Slave Mode

6.7 Typical Characteristics

at 25°C, AVDD = DRVDD = IOVDD = 3.3 V, DVDD = 1.8 V, $f_s = 48$ kHz, and 16-bit audio data (unless otherwise noted)

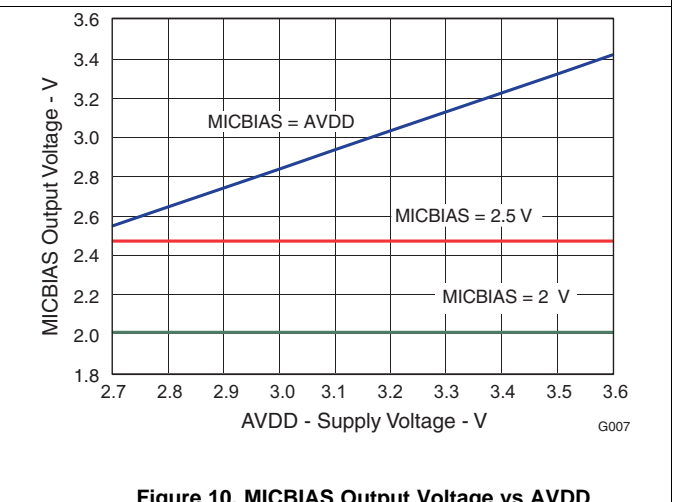
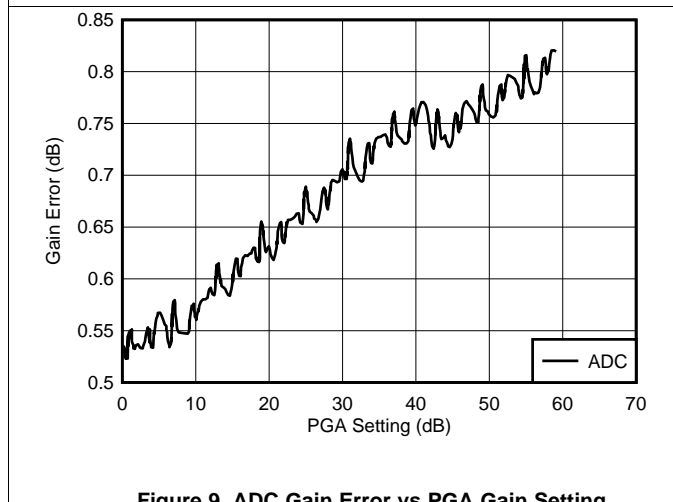
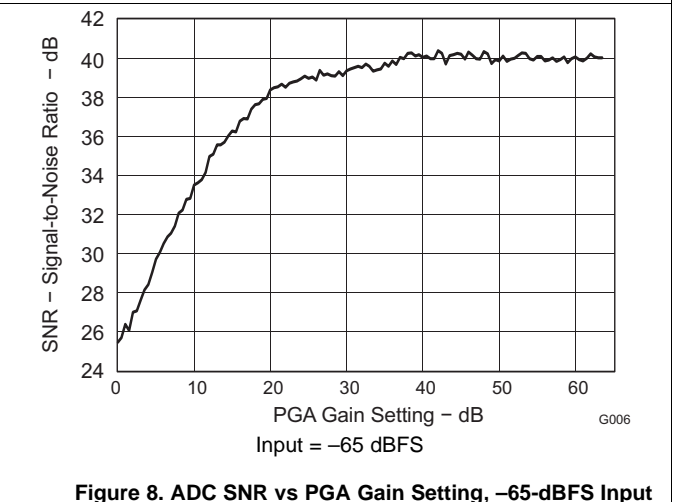
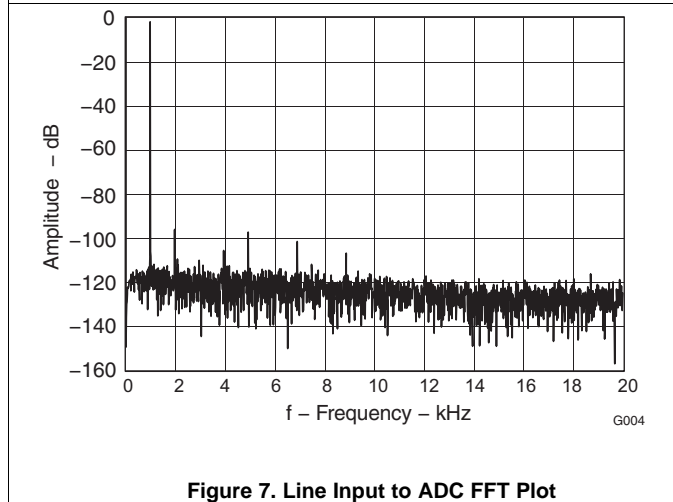
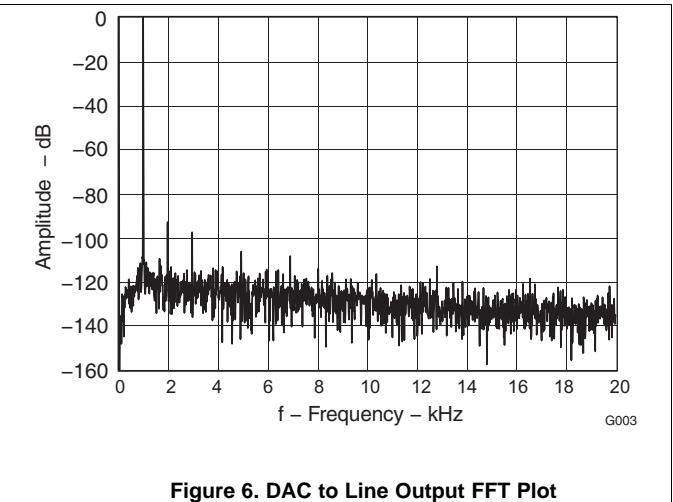
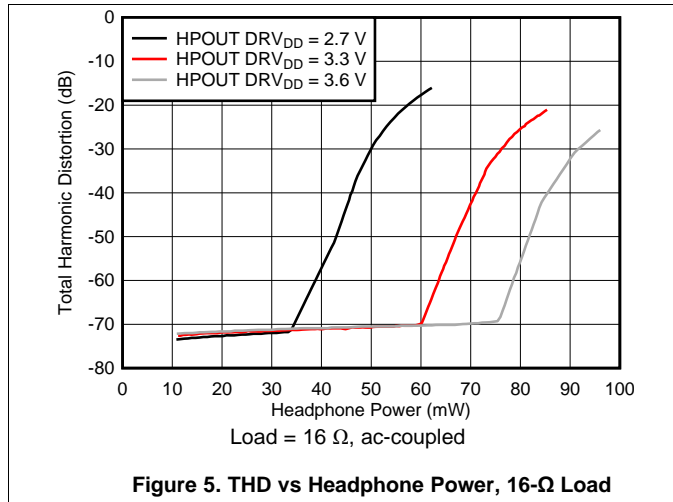

Typical Characteristics (continued)

at 25°C, AVDD = DRVDD = IOVDD = 3.3 V, DVDD = 1.8 V, f_s = 48 kHz, and 16-bit audio data (unless otherwise noted)

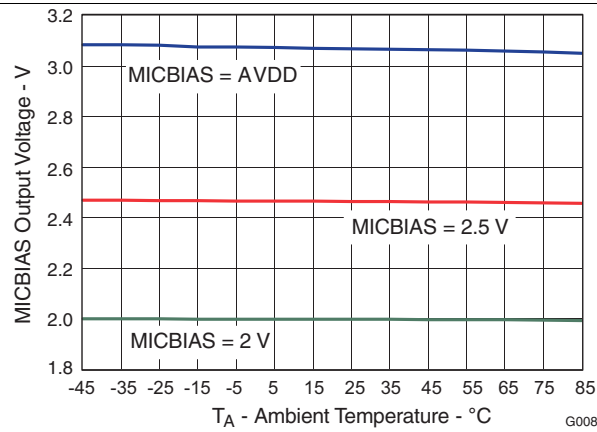

Figure 11. MICBIAS Output Voltage vs Ambient Temperature

7 Detailed Description

7.1 Overview

The TLV320AIC3109-Q1 is a highly flexible, low-power, mono audio codec with extensive feature integration intended for automotive applications. Available in a 5-mm x 5-mm, 32-lead VQFN, the device integrates a host of features to reduce cost, board space, and power consumption in space-constrained, battery-powered, portable applications.

The TLV320AIC3109-Q1 consists of the following blocks:

- Mono audio multi-bit, delta-sigma digital-to-analog converter (DAC): 8 kHz–96 kHz
- Mono audio multi-bit, delta-sigma analog-to-digital converter (ADC): 8 kHz–96 kHz
- Programmable gain amplifier (PGA): 0-dB to 59.5-dB gain
- Programmable digital audio effects processing (bass, treble, midrange, EQ, notch filter, de-emphasis)
- Two differential or two single-ended microphone or line inputs
- One differential or two single-ended headphone drivers
- Two fully differential line output drivers
- Fully programmable PLL
- Headphone, headset jack detection available as a register status bit

7.2 Functional Block Diagram

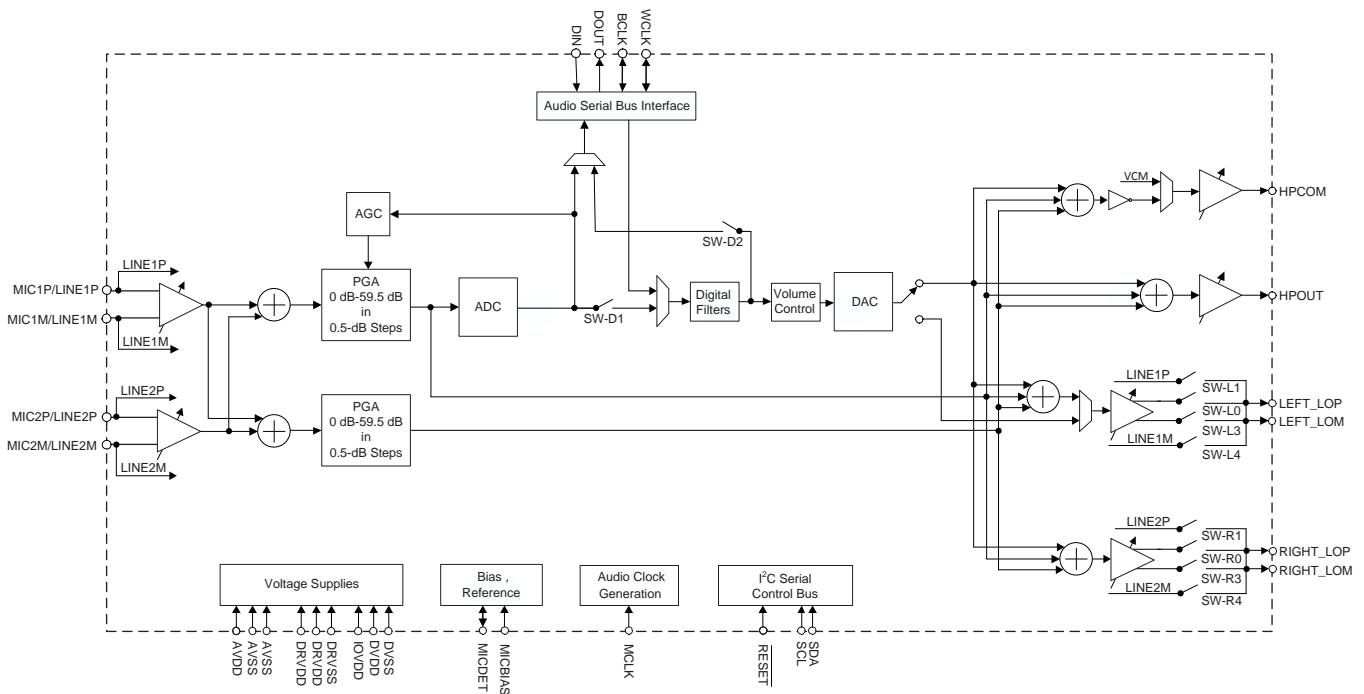

7.3 Feature Description

7.3.1 Hardware Reset

The TLV320AIC3109-Q1 requires a hardware reset after power-up for proper operation. After all power supplies are at their specified values, the RESET pin must be driven low for at least 10 ns. If this reset sequence is not performed, the TLV320AIC3109-Q1 may not respond properly to register reads or writes.

This device also offers a software reset (page 0, register 1) that can be used by the host to reset all registers on page 0 and page 1 to their reset values. In cases where changes are needed only for routing or volume-control registers, these changes can be accomplished by writing directly to the appropriate registers rather than using the software or hardware reset.

In cases where the ESD events generate a device reset, a minimum 1-nF capacitor is recommended to be connected between the RESET pin and DVSS. This capacitor avoids ESD events that can place the codec in default state.

7.3.2 Digital Audio Data Serial Interface

Audio data are transferred between the host processor and the TLV320AIC3109-Q1 via the digital audio data serial interface. The audio bus of the TLV320AIC3109-Q1 can be configured for left- or right-justified, I²S, DSP, or TDM modes of operation, where communication with standard PCM interfaces is supported within TDM mode. These modes are all MSB-first, with data width programmable as 16, 20, 24, or 32 bits. In addition, the word clock (WCLK) and bit clock (BCLK) can be independently configured in either master or slave mode for flexible connectivity to a wide variety of processors.

The word clock (WCLK) is used to define the beginning of a frame, and can be programmed as either a pulse or a square-wave signal. The frequency of this clock corresponds to the selected ADC and DAC sampling frequency.

The bit clock (BCLK) is used to clock in and out the digital audio data across the serial bus. When in master mode, this signal can be programmed in two further modes: continuous transfer mode, and 256-clock mode. In continuous transfer mode, only the minimal number of bit clocks required to transfer the audio data are generated, so in general the number of bit clocks per frame is two times the data width. For example, if the data width is chosen as 16 bits, then 32-bit clocks are generated per frame. If the bit clock signal in master mode is to be used by a PLL in another device, then the 16-bit or 32-bit data-width selections are recommended be used. These cases result in a low-jitter bit clock signal being generated, with frequencies of $32 f_s$ or $64 f_s$. For a 20-bit and 24-bit data width in master mode, the bit clocks generated in each frame are not all of equal period because the device does not have a clean $40 f_s$ or $48 f_s$ clock signal readily available. The average frequency of the bit clock signal is still accurate in these cases ($40 f_s$ or $48 f_s$), but the resulting clock signal has higher jitter than in the 16-bit and 32-bit cases.

In 256-clock mode, a constant 256 bit clocks per frame are generated, independent of the data width chosen. The TLV320AIC3109-Q1 further includes programmability to place the DOUT line in the high-impedance state during all bit clocks when valid data are not being sent. By combining this capability with the ability to program at what bit clock in a frame the audio data begins, time-division multiplexing (TDM) can be accomplished, resulting in multiple codecs able to use a single audio serial data bus.

When the digital audio data serial interface is powered down when configured in master mode, the pins associated with the interface are put into a high-impedance state.

The following subsections describe the supported data interface protocols. These protocols can be used for left- and right-channel applications. Only one of the two possible channels can be selected because the TLV320AIC3109-Q1 is a mono audio codec. Only the left channel is valid for DOUT (output data). For DIN (input data), valid data can be selected with bits 4 and 3 of register 7, page 0.

Feature Description (continued)

7.3.2.1 Right-Justified Mode

In right-justified mode, the LSB of the left channel is valid on the rising edge of the bit clock preceding the falling edge of the word clock. Similarly, the LSB of the right channel is valid on the rising edge of the bit clock preceding the rising edge of the word clock. [Figure 12](#) shows a timing diagram of this operation.

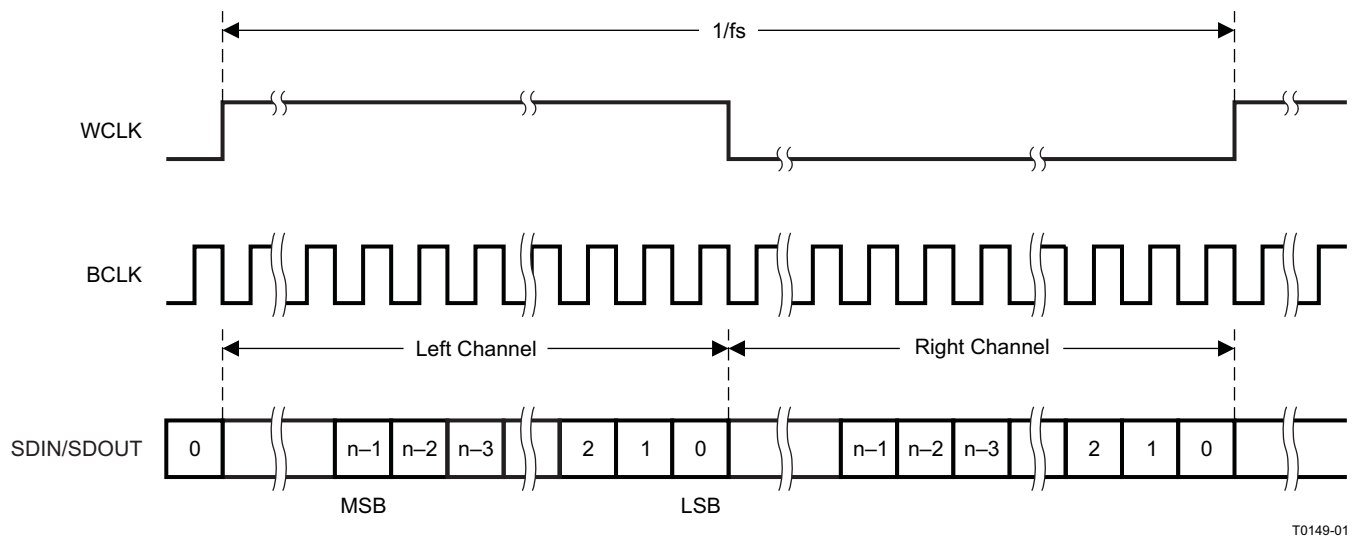

Figure 12. Right-Justified Serial Data Bus Mode Operation

7.3.2.2 Left-Justified Mode

In left-justified mode, the MSB of the right channel is valid on the rising edge of the bit clock following the falling edge of the word clock. Similarly, the MSB of the left channel is valid on the rising edge of the bit clock following the rising edge of the word clock. [Figure 13](#) shows a timing diagram of this operation.

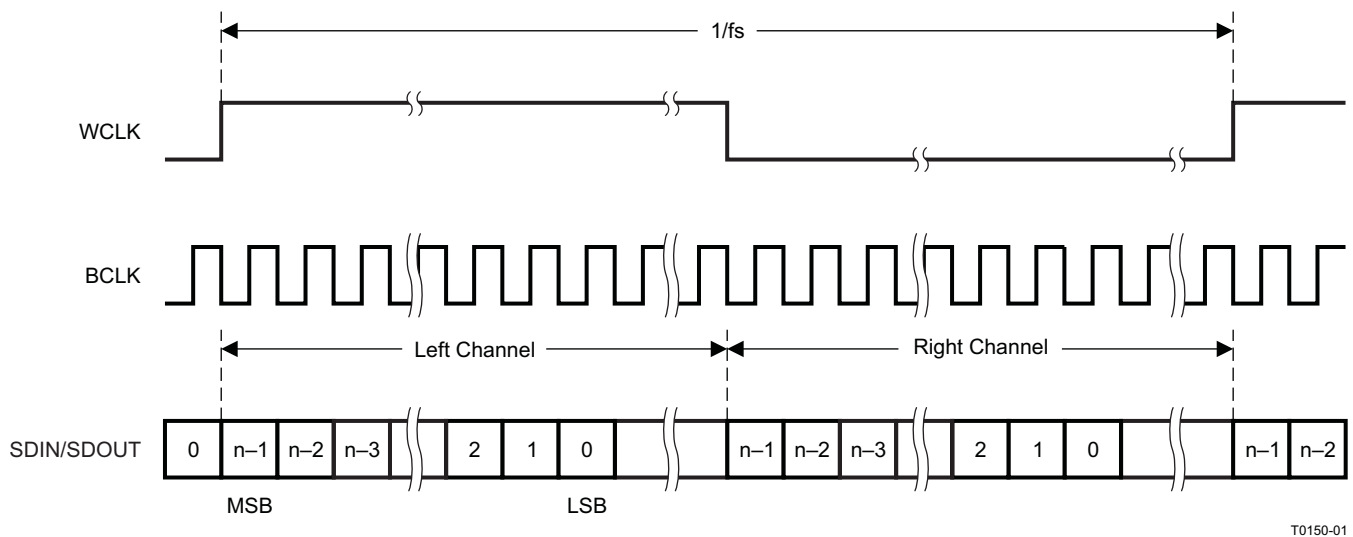

Figure 13. Left-Justified Serial Data Bus Mode Operation

Feature Description (continued)

7.3.2.3 I²S Mode

In I²S mode, the MSB of the left channel is valid on the second rising edge of the bit clock after the falling edge of the word clock. Similarly, the MSB of the right channel is valid on the second rising edge of the bit clock after the rising edge of the word clock. Figure 14 shows a timing diagram of this operation.

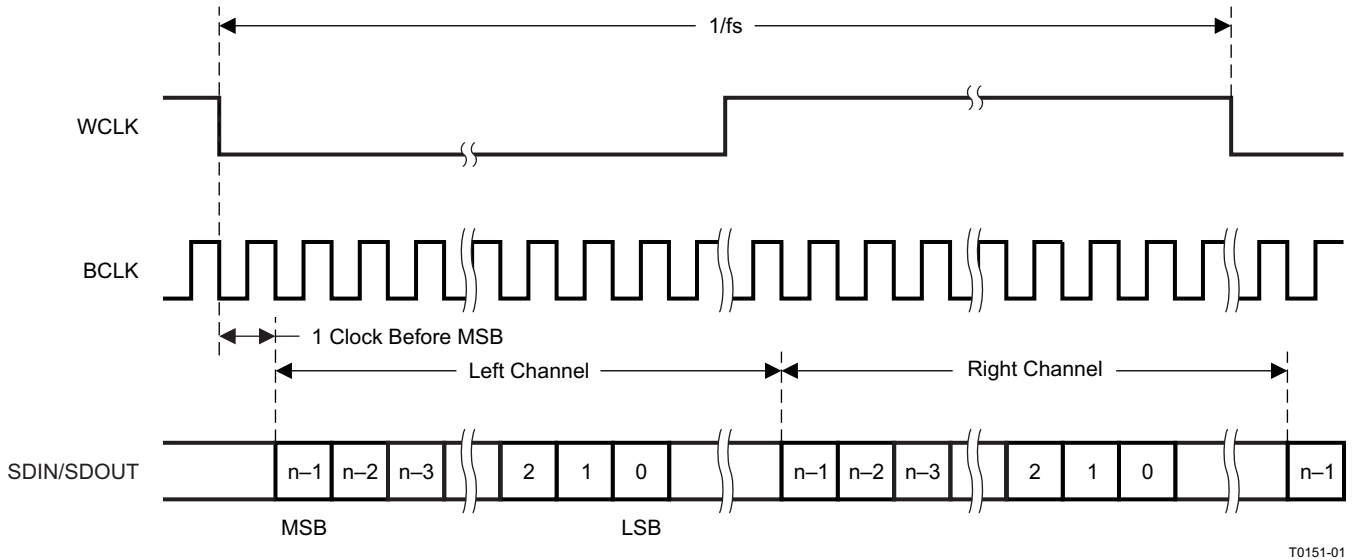

Figure 14. I²S Serial Data Bus Mode Operation

7.3.2.4 DSP Mode

In DSP mode, the rising edge of the word clock starts the data transfer with the left-channel data first, immediately followed by the right-channel data. Each data bit is valid on the falling edge of the bit clock. Figure 15 shows a timing diagram of this operation.

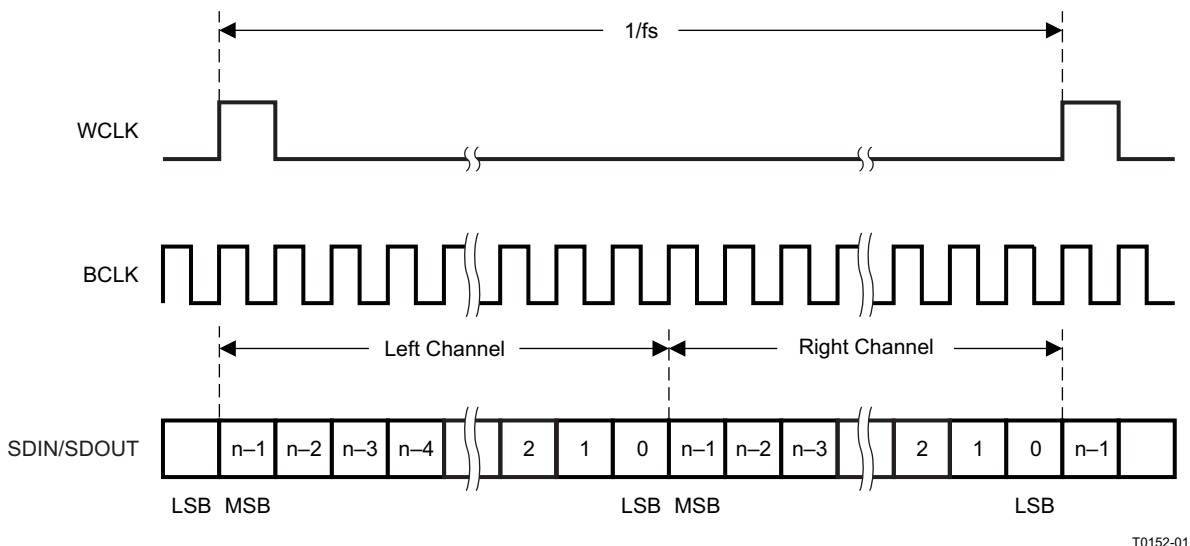

Figure 15. DSP Serial Data Bus Mode Operation

Feature Description (continued)

7.3.2.5 TDM Data Transfer

Time-division multiplexed data transfer can be realized in any of the left-justified transfer modes if the 256-clock bit-clock mode is selected, although it is recommended to be used in either left-justified mode or DSP mode. By changing the programmable offset, the bit clock in each frame where the data begins can be changed, and the serial data output driver (DOUT) can also be programmed to the high-impedance state during all bit clocks except when valid data is being put onto the bus. This format allows other codecs to be programmed with different offsets and to drive their data onto the same DOUT line, just in a different slot. For incoming data, the codec simply ignores data on the bus except when expected based on the programmed offset.

The location of the data when an offset is programmed is different depending on what transfer mode is selected. In DSP mode, both the left and right channels of data are transferred immediately adjacent to each other in the frame. This configuration differs from left-justified mode, where the left- and right-channel data are always a half-frame apart in each frame. In this case, when the offset is programmed from zero to some higher value, both the left- and right-channel data move across the frame, but still stay a full half-frame apart from each other. [Figure 16](#) shows the TDM transfer for DSP mode and left-justified mode.

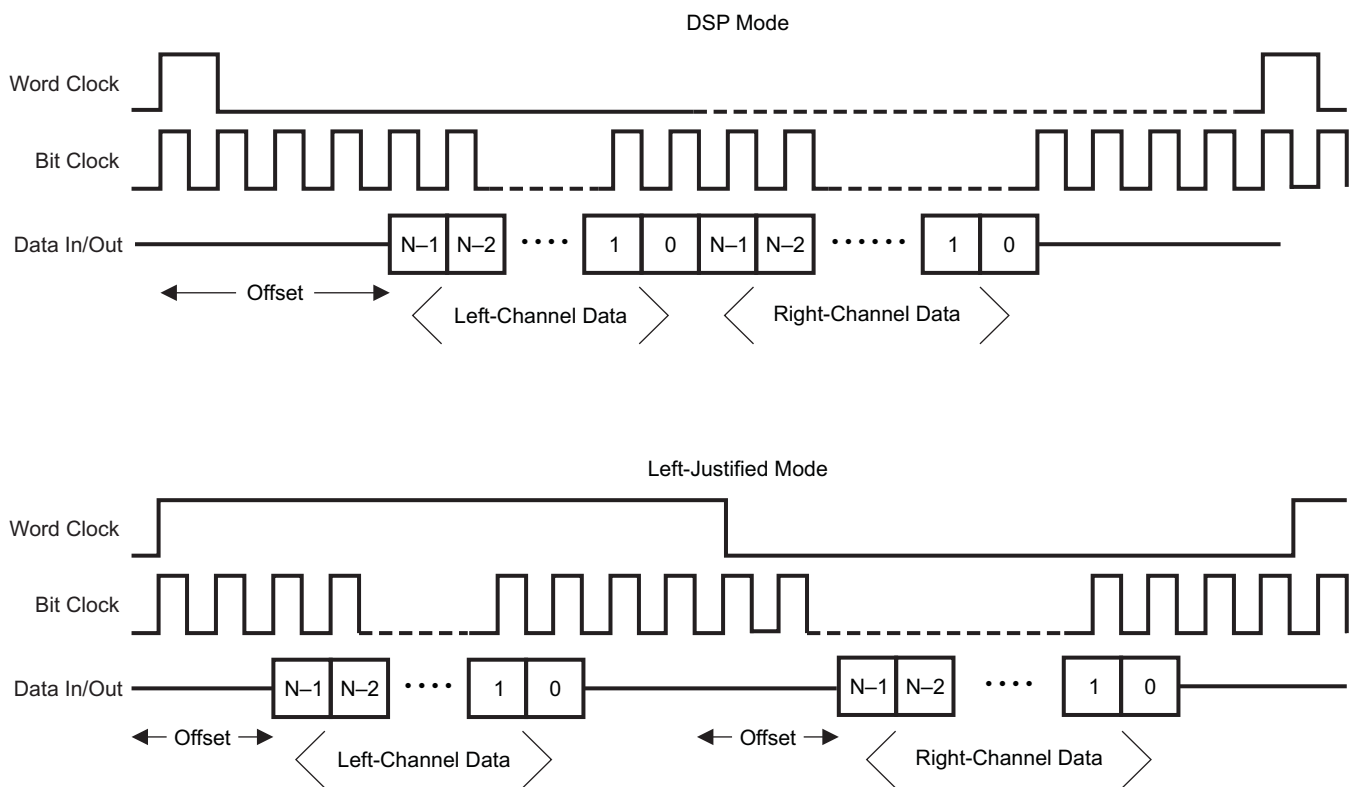

T0153-01

Figure 16. DSP Mode and Left-Justified Mode, Showing the Effect of a Programmed Data-Word Offset

7.3.3 Audio Data Converters

The TLV320AIC3109-Q1 supports the following standard audio sampling rates: 8 kHz, 11.025 kHz, 12 kHz, 16 kHz, 22.05 kHz, 24 kHz, 32 kHz, 44.1 kHz, 48 kHz, 88.2 kHz, and 96 kHz. The converters also can operate at different sampling rates in various combinations, as described in this section.

The data converters are based on the concept of an $f_{S(\text{ref})}$ rate that is used internal to the device, and is related to the actual sampling rates of the converters through a series of ratios. For typical sampling rates, $f_{S(\text{ref})}$ is either 44.1 kHz or 48 kHz, although $f_{S(\text{ref})}$ can realistically be set over a wider range of rates up to 53 kHz, with additional restrictions if the PLL is used. This concept is used to set the sampling rates of the ADC and DAC, and also to enable high-quality playback of low-sampling-rate data without high-frequency audible noise being generated.

Feature Description (continued)

The sampling rate of the ADC and DAC is determined by the clock divider (NCODEC). The sampling rate can be set to $f_{S(\text{ref})} / \text{NCODEC}$ or $2 \times f_{S(\text{ref})} / \text{NCODEC}$, with NCODEC being 1, 1.5, 2, 2.5, 3, 3.5, 4, 4.5, 5, 5.5, or 6 for both the NDAC and NADC settings. In the TLV320AIC3109-Q1, NDAC and NADC must be set to the same value because the device only supports a common sampling rate for the ADC and DAC channels. Therefore, NCODEC = NDAC = NADC and this value is programmed by setting the value of bits 7–4 equal to the value of bits 3–0 in register 2, page 0.

7.3.3.1 Audio Clock Generation

The audio converters in the TLV320AIC3109-Q1 need an internal audio master clock at a frequency of $256 f_{S(\text{ref})}$, which can be obtained in a variety of manners from an external clock signal applied to the device. Figure 17 shows a detailed diagram of the audio clock section of the TLV320AIC3109-Q1.

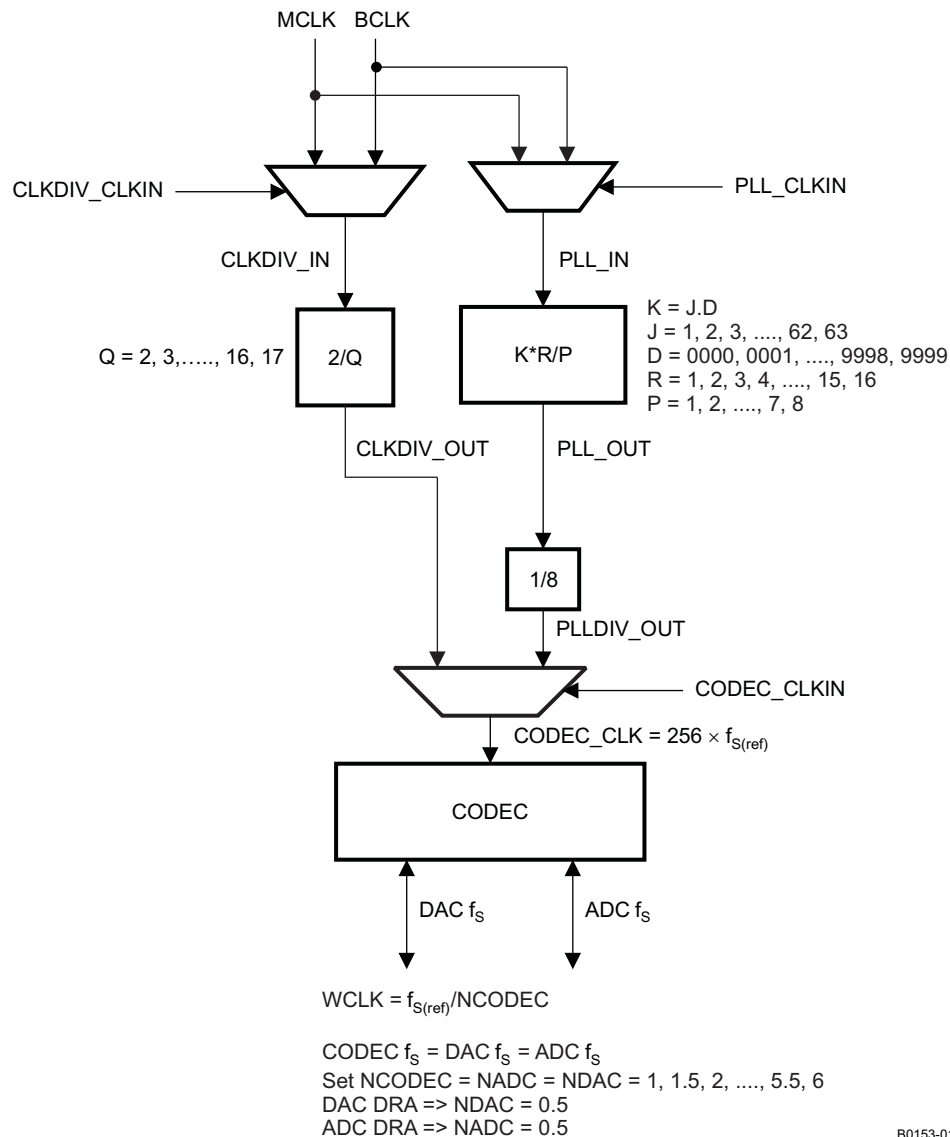

Figure 17. Audio Clock Generation Processing

The device can accept an MCLK input from 512 kHz to 50 MHz that can then be passed through either a programmable divider or a PLL to get the proper internal audio master clock required by the device. The BCLK input can also be used to generate the internal audio master clock.

Feature Description (continued)

A primary concern is proper operation of the codec at various sample rates with the limited MCLK frequencies available in the system. This device includes a highly programmable PLL to accommodate such situations easily. The integrated PLL can generate audio clocks from a wide variety of possible MCLK inputs, with particular focus paid to the standard MCLK rates already widely used.

When the PLL is disabled,

$$f_{S(\text{ref})} = \text{CLKDIV_IN} / (128 \times Q)$$

where

- $Q = 2, 3 \dots 17$; Q is register-programmable and can be set by bits 6–3 in register 3, page 0 (1)

CLKDIV_IN can be MCLK or BCLK, selected by register 102, bits 7–6.

NOTE

When NCODEC = 1.5, 2.5, 3.5, 4.5, or 5.5, odd values of Q are not allowed. In this mode, MCLK can be as high as 50 MHz, and $f_{S(\text{ref})}$ must fall within 39 kHz to 53 kHz, inclusively.

When the PLL is enabled,

$$f_{S(\text{ref})} = (\text{PLLCLK_IN} \times K \times R) / (2048 \times P)$$

where

- $P = 1, 2, 3 \dots 8$
- $R = 1, 2 \dots 16$
- $K = J.D$
- $J = 1, 2, 3 \dots 63$
- $D = 0000, 0001, 0002, 0003 \dots 9998, 9999$
- PLLCLK_IN can be MCLK or BCLK, selected by bits 5–4 in register 102, page 0 (2)

P, R, J, and D are register programmable. J is the integer portion of K (the numbers to the left of the decimal point), whereas D is the fractional portion of K (the numbers to the right of the decimal point, assuming four digits of precision). P can be set by bits 2–0 in register 3, page 0. R can be set by bits 3–0 in register 11, page 0. J can be set by bits 7–2 in register 4, page 0. The most-significant bits of D can be set by bits 7–0 in register 5, page 0, and the least-significant bits of D can be set by bits 7–2 in register 6, page 0.

Examples:

If $K = 8.5$, then $J = 8$, $D = 5000$

If $K = 7.12$, then $J = 7$, $D = 1200$

If $K = 14.03$, then $J = 14$, $D = 0300$

If $K = 6.0004$, then $J = 6$, $D = 0004$

When the PLL is enabled and $D = 0000$, the following conditions must be satisfied to meet specified performance:

$$2 \text{ MHz} \leq (\text{PLLCLK_IN} / P) \leq 20 \text{ MHz}$$

$$80 \text{ MHz} \leq (\text{PLLCLK_IN} \times K \times R / P) \leq 110 \text{ MHz}$$

$$4 \leq J \leq 55$$

When the PLL is enabled and $D \neq 0000$, the following conditions must be satisfied to meet specified performance:

$$10 \text{ MHz} \leq \text{PLLCLK_IN} / P \leq 20 \text{ MHz}$$

$$80 \text{ MHz} \leq \text{PLLCLK_IN} \times K \times R / P \leq 110 \text{ MHz}$$

$$4 \leq J \leq 11$$

$$R = 1$$

Example:

MCLK = 12 MHz and $f_{S(\text{ref})} = 44.1 \text{ kHz}$

Select $P = 1$, $R = 1$, $K = 7.5264$, which results in $J = 7$, $D = 5264$

Feature Description (continued)

Example:

MCLK = 12 MHz and $f_{S(\text{ref})} = 48$ kHz

Select $P = 1$, $R = 1$, $K = 8.192$, which results in $J = 8$, $D = 1920$

Table 1 lists several example cases of typical MCLK rates and how to program the PLL to achieve $f_{S(\text{ref})} = 44.1$ kHz or 48 kHz.

Table 1. Typical MCLK Rates

MCLK (MHz)	P	R	J	D	ACHIEVED $f_{S(\text{ref})}$	% ERROR
$f_{S(\text{ref})} = 44.1$ kHz						
2.8224	1	1	32	0	44,100	0
5.6448	1	1	16	0	44,100	0
12	1	1	7	5264	44,100	0
13	1	1	6	9474	44,099.71	-0.0007
16	1	1	5	6448	44,100	0
19.2	1	1	4	7040	44,100	0
19.68	1	1	4	5893	44,100.3	0.0007
48	4	1	7	5264	44,100	0
$f_{S(\text{ref})} = 48$ kHz						
2.048	1	1	48	0	48,000	0
3.072	1	1	32	0	48,000	0
4.096	1	1	24	0	48,000	0
6.144	1	1	16	0	48,000	0
8.192	1	1	12	0	48,000	0
12	1	1	8	1920	48,000	0
13	1	1	7	5618	47,999.71	-0.0006
16	1	1	6	1440	48,000	0
19.2	1	1	5	1200	48,000	0
19.68	1	1	4	9951	47,999.79	-0.0004
48	4	1	8	1920	48,000	0

7.3.3.2 Mono Audio ADC

The TLV320AIC3109-Q1 includes a mono audio ADC that uses a delta-sigma modulator with 128-times oversampling in single-rate mode, followed by a digital decimation filter. The ADC supports sampling rates from 8 kHz to 96 kHz. Whenever the ADC or DAC is in operation, the device requires that an audio master clock be provided and appropriate audio clock generation be set up within the device.

The integrated digital decimation filter removes high-frequency content and downsamples the audio data from an initial sampling rate of $128 f_S$ to the final output sampling rate of f_S . The decimation filter provides a linear phase output response with a group delay of $17 / f_S$. The -3-dB bandwidth of the decimation filter extends to $0.45 f_S$ and scales with the sample rate (f_S). The filter has minimum 75-dB attenuation over the stop band from $0.55 f_S$ to $64 f_S$. The device also provide options to select the corner frequency of the digital high-pass filter.

Requirements for analog antialiasing filtering are very relaxed because of the oversampling nature of the audio ADC and the integrated digital decimation filtering. The TLV320AIC3109-Q1 integrates a second-order analog antialiasing filter with 20-dB attenuation at 1 MHz. This filter, combined with the digital decimation filter, provides sufficient antialiasing filtering without requiring additional external components.

The ADC is preceded by a programmable gain amplifier (PGA) that allows analog gain control from 0 dB to 59.5 dB in steps of 0.5 dB. The PGA gain changes are implemented with an internal soft-stepping algorithm that only changes the actual volume level by one 0.5-dB step every one or two ADC output samples, depending on the register programming (see registers 19 and 22, page 0). This soft-stepping ensures that volume control changes occur smoothly with no audible artifacts. On reset, the PGA gain defaults to a mute condition, and on

power-down, the PGA soft-steps the volume to mute before shutting down. A read-only flag is set whenever the gain applied by PGA equals the desired value set by the register. The soft-stepping control can also be disabled by programming a register bit. When soft-stepping is enabled, the audio master clock must be applied to the device after the ADC power-down register is written to ensure the soft-stepping to mute has completed. When the ADC power-down flag is no longer set, the audio master clock can be shut down.

An additional auxiliary PGA is provided to allow the mixing of the DAC output signals with an input not routed through the ADC. This PGA has the same specifications as the ADC PGA.

7.3.3.2.1 Mono Audio ADC High-Pass Filter

Often in audio applications, the dc offset needs to be removed from the converted audio data stream. The TLV320AIC3109-Q1 has a programmable first-order, high-pass filter that can be used for this purpose. The digital filter coefficients are in 16-bit format and therefore use two 8-bit registers for each of the three coefficients, N0, N1, and D1. [Equation 3](#) shows the form of the digital high-pass filter transfer function:

$$H(z) = \frac{N0 + N1 \times z^{-1}}{32,768 - D1 \times z^{-1}} \quad (3)$$

Programming the channel is done by writing to registers 65–70, page 1. After the coefficients are loaded, these ADC high-pass filter coefficients can be selected by writing to bit 7 in register 107, page 0, and the high-pass filter can be enabled by writing to bit 7 in register 12, page 0.

7.3.3.2.2 Automatic Gain Control (AGC)

An automatic gain control (AGC) circuit is included with the ADC and can be used to maintain nominally constant output signal amplitude when recording speech signals (the AGC can be fully disabled if not needed). This circuitry automatically adjusts the PGA gain when the input signal becomes overly loud or very weak, such as when a person speaking into a microphone moves closer or farther from the microphone. The AGC algorithm has several programmable settings, including target level, attack and decay time constants, noise threshold, and maximum PGA gain applicable that allow the algorithm to be fine-tuned for any particular application. These AGC features are explained in this section, and [Figure 18](#) illustrates their operation. The algorithm uses the absolute average of the signal (which is the average of the absolute value of the signal) as a measure of the nominal amplitude of the output signal.

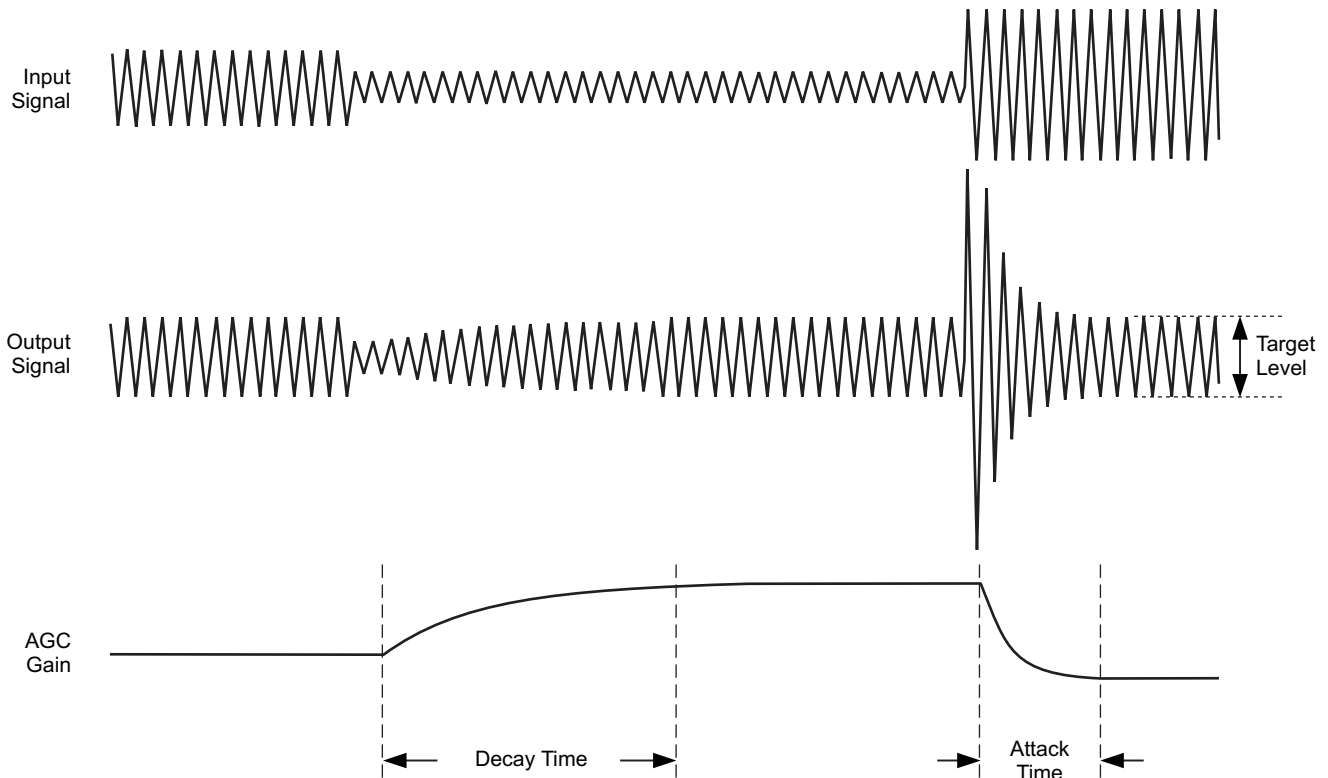

W0002-01

Figure 18. Typical Operation of the AGC Algorithm During Speech Recording

7.3.3.2.2.1 Target Level

Target value represents the nominal output level at which the AGC attempts to hold the ADC output signal level. The TLV320AIC3109-Q1 allows programming of eight different target levels, which can be programmed from -5.5 dB to -24 dB relative to a full-scale signal. The target level is recommended to be set with enough margin to avoid clipping at the occurrence of loud sounds because the device reacts to the signal absolute average and not to peak levels.

7.3.3.2.2.2 Attack Time

Attack time determines how quickly the AGC circuitry reduces the PGA gain when the input signal is too loud. It Attack time can be varied from 7 ms to 1,408 ms. The attack time can be programmed by writing to register 105, page 0.

7.3.3.2.2.3 Decay Time

Decay time determines how quickly the PGA gain is increased when the input signal is too low. It Decay time can be varied in the range from 0.05 s to 22.4 s. Decay time is programmed by writing to register 106, page 0.

The actual maximum AGC decay time is based on a counter length, so the maximum decay time scales with the clock setup that is used. Table 2 lists the relationship of the NCODEC ratio to the maximum time available for the AGC decay. In practice, these maximum times are extremely long for audio applications and must not limit any practical AGC decay time that is needed by the system.

Table 2. AGC Decay Time Restriction

NCODEC RATIO	MAXIMUM DECAY TIME (SECONDS)
1	4
1.5	5.6
2	8
2.5	9.6
3	11.2
3.5	11.2
4	16
4.5	16
5	19.2
5.5	22.4
6	22.4

7.3.3.2.4 Noise Gate Threshold

If the input speech average value falls below the level determined by this threshold, the AGC considers the speech input to be silent and brings down the gain to 0 dB in steps of 0.5 dB every sample period and sets the noise threshold flag. The gain stays at 0 dB unless the input speech signal average rises above the noise threshold setting. This threshold ensures that noise is not gained up during times of silence. The noise threshold level in the AGC algorithm is programmable from –30 dB to –90 dB relative to full-scale. A disable noise gate feature is also available. This operation includes programmable debounce and hysteresis functionality to avoid the AGC gain from cycling between high gain and 0 dB when signals are near the noise threshold level. When the noise threshold flag is set, ignore the status of gain applied by the AGC and the saturation flag.

7.3.3.2.5 Maximum PGA Gain Applicable

The maximum PGA gain that can be applied by the AGC algorithm can be restricted. This restriction can be used for limiting PGA gain in situations where environmental noise is greater than the programmed noise threshold. The PGA gain can be programmed from 0 dB to 59.5 dB in steps of 0.5 dB.

The time constants are correct when the ADC is not in double-rate audio mode. The time constants are achieved by using the $f_{S(\text{ref})}$ value programmed in the control registers. However, if the $f_{S(\text{ref})}$ is set in the registers (for example, to 48 kHz), but the actual audio clock or PLL programming results in a different $f_{S(\text{ref})}$ in practice, then the time constants are incorrect; see the [Decay Time](#) section for more information.

7.3.4 Mono Audio DAC

The TLV320AIC3109-Q1 includes a mono audio DAC supporting sampling rates from 8 kHz to 96 kHz. The DAC consists of a digital audio processing block, a digital interpolation filter, a multi-bit digital delta-sigma modulator, and an analog reconstruction filter. The DAC is designed to provide enhanced performance at low sampling rates through increased oversampling and image filtering, thereby keeping quantization noise generated within the delta-sigma modulator and signal images strongly suppressed within the audio band to beyond 20 kHz. This is realized by keeping the upsampled rate constant at $128 f_{S(\text{ref})}$ and changing the oversampling ratio when the input sample rate changes. For an $f_{S(\text{ref})}$ of 48 kHz, the digital delta-sigma modulator always operates at a rate of 6.144 MHz, which ensures that quantization noise generated within the delta-sigma modulator stays low within the frequency band below 20 kHz at all sample rates. Similarly, for an $f_{S(\text{ref})}$ rate of 44.1 kHz, the digital delta-sigma modulator always operates at a rate of 5.6448 MHz.

The following restrictions apply in the case when the PLL is powered down and double-rate audio mode is enabled in the DAC.

- Allowed Q values = 4, 8, 9, 12, 16
- Q values where equivalent $f_{S(\text{ref})}$ can be achieved by turning on the PLL
- Q = 5, 6, 7 (set P = 5, 6, or 7, K = 16, and PLL enabled)
- Q = 10, 14 (set P = 5 or 7, K = 8, and PLL enabled)

7.3.4.1 Digital Audio Processing for Playback

The DAC channel consists of optional filters for de-emphasis and bass, treble, midrange level adjustment, and speaker equalization. The de-emphasis function is implemented by a programmable digital filter block with fully programmable coefficients (see registers 21–26, page 1). If de-emphasis is not required in a particular application, this programmable filter block can be used for some other purpose. Equation 4 gives the de-emphasis filter transfer function:

$$H(z) = \frac{N0 + N1 \times z^{-1}}{32,768 - D1 \times z^{-1}}$$

where

- The N0, N1, and D1 coefficients are fully programmable individually (4)

Table 3 lists the coefficients that must be loaded to implement standard de-emphasis filters.

Table 3. De-Emphasis Coefficients for Common Audio Sampling Rates

SAMPLING FREQUENCY	N0	N1	D1
32 kHz	16,950	–1,220	17,037
44.1 kHz	15,091	–2,877	20,555
48 kHz ⁽¹⁾	14,677	–3,283	21,374

(1) The 48-kHz coefficients listed in Table 3 are used as defaults.

In addition to the de-emphasis filter block, the DAC digital effects processing includes a fourth-order digital IIR filter with programmable coefficients. This filter is implemented as a cascade of two biquad sections with the frequency response given by:

$$\left(\frac{N0 + 2 \times N1 \times z^{-1} + N2 \times z^{-2}}{32,768 - 2 \times D1 \times z^{-1} - D2 \times z^{-2}} \right) \left(\frac{N3 + 2 \times N4 \times z^{-1} + N5 \times z^{-2}}{32,768 - 2 \times D4 \times z^{-1} - D5 \times z^{-2}} \right) \quad (5)$$

The N and D coefficients are fully programmable and the entire filter can be enabled or bypassed. The structure of the filtering when configured for channel processing is illustrated in Figure 19, with LB1 corresponding to the first biquad filter using coefficients N0, N1, N2, D1, and D2. LB2 similarly corresponds to the second biquad filter using coefficients N3, N4, N5, D4, and D5.

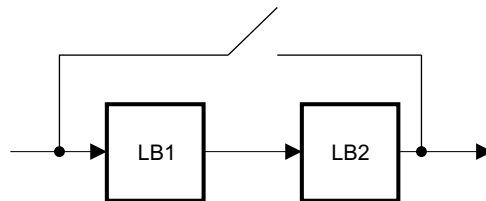

B0154-01

Figure 19. Structure of Digital Effects Processing for Channel Processing

The coefficients for this filter implement a variety of sound effects, with bass boost or treble boost being the most commonly used in portable audio applications. The default N and D coefficients in the device are given in Table 4 and implement a shelving filter with 0-dB gain from dc to approximately 150 Hz, at which point the filter rolls off to a 3-dB attenuation for higher frequency signals, thus giving a 3-dB boost to signals below 150 Hz. The N and D coefficients are represented by 16-bit, 2's-complement numbers with values ranging from –32,768 to 32,767.

Table 4. Default Digital Effects Processing Filter Coefficients, When in Independent Channel Processing Configuration

COEFFICIENTS				
N0 = N3	D1 = D4	N1 = N4	D2 = D5	N2 = N5
27,619	32,131	–27,034	–31,506	26,461

The digital effects filters are recommended to be disabled when the filter coefficients are being modified. When new coefficients are being written to the device over the control port, a filter using partially updated coefficients can possibly implement an unstable system and lead to oscillation or objectionable audio output. By disabling the filters, changing the coefficients, and then reenabling the filters, these types of effects can be entirely avoided.

7.3.4.2 Digital Interpolation Filter

The digital interpolation filter upsamples the output of the digital audio processing block by the required oversampling ratio before data are provided to the digital delta-sigma modulator and analog reconstruction filter stages. The filter provides a linear phase output with a group delay of $21 / f_S$. In addition, programmable digital interpolation filtering is included to provide enhanced image filtering and reduce signal images caused by the upsampling process that are below 20 kHz. For example, upsampling an 8-kHz signal produces signal images at multiples of 8-kHz (that is, 8 kHz, 16 kHz, 24 kHz, and so forth). The images at 8 kHz and 16 kHz are below 20 kHz and are still audible to the listener; therefore, these images must be filtered heavily to maintain a good quality output. The interpolation filter is designed to maintain at least 65-dB rejection of images that are below $7.455 f_S$. In order to use the programmable interpolation capability, program $f_{S(\text{ref})}$ to a higher rate (restricted to be in the range of 39 kHz to 53 kHz when the PLL is in use), and the actual f_S is set using the NCODEC divider, where $\text{NCODEC} = \text{NDAC} = \text{NADC}$. For example, if $f_S = 8$ kHz is required, then $f_{S(\text{ref})}$ can be set to 48 kHz and the DAC f_S set to $f_{S(\text{ref})} / 6$. This setting ensures that all images of the 8-kHz data are sufficiently attenuated well beyond a 20-kHz audible frequency range.

7.3.4.3 Delta-Sigma Audio DAC

The mono audio DAC incorporates a third-order, multi-bit, delta-sigma modulator followed by an analog reconstruction filter. The DAC provides high-resolution, low-noise performance, using oversampling and noise shaping techniques. The analog reconstruction filter design consists of a six-tap analog FIR filter followed by a continuous-time RC filter. The analog FIR operates at a rate of $128 f_{S(\text{ref})}$ (6.144 MHz when $f_{S(\text{ref})} = 48$ kHz, 5.6448 MHz when $f_{S(\text{ref})} = 44.1$ kHz). The DAC analog performance can be degraded by excessive clock jitter on the MCLK input. Therefore, care must be taken to keep jitter on this clock to a minimum.

7.3.4.4 Audio DAC Digital Volume Control

The audio DAC includes a digital volume control block that implements a programmable digital gain. The volume level can be varied from 0 dB to –63.5 dB in 0.5-dB steps, or set to mute, independently for each channel. The volume level can also be changed by the master volume control. Gain changes are implemented with a soft-stepping algorithm that only changes the actual volume by one step per input sample, either up or down, until the desired volume is reached. The rate of soft-stepping can be slowed to one step per two input samples through a register bit.

The host does not know when the DAC is muted because of the soft-stepping, which may be important if the host wishes to mute the DAC before making a significant change, such as changing sample rates. In order to help with this situation, the device provides a flag back to the host via a read-only register bit that alerts the host when the device completes the soft-stepping and the actual volume reaches the desired volume level. The soft-stepping feature can be disabled through register programming. If soft-stepping is enabled, keep the MCLK signal applied to the device until the DAC power-down flag is set. When this flag is set, the internal soft-stepping process and power-down sequence is complete, and the MCLK can then be stopped if desired.

The TLV320AIC3109-Q1 also includes functionality to detect when the selection of de-emphasis or digital audio processing functionality is changed. When the new selection is detected, the TLV320AIC3109-Q1 (1) soft-mutes the DAC volume control, (2) changes the operation of the digital effects processing to match the new selection, and (3) soft-unmutes the device. These steps avoid any possible pops or clicks in the audio output resulting from instantaneous changes in the filtering. A similar algorithm is used when first powering up or powering down the DAC. The circuit begins operation at power-up with the volume control muted, then soft-steps the volume up to the desired level. At power-down, the logic first soft-steps the volume down to a mute level, then powers down the circuitry.

7.3.4.5 Increasing DAC Dynamic Range

The TLV320AIC3109-Q1 allows trading off dynamic range with power consumption. The DAC dynamic range can be increased by writing to bits 7–6 in register 109, page 0. The lowest DAC current setting is the default, and the dynamic range is displayed in the *Audio DAC, Differential Line Output* section of the [Electrical Characteristics](#) table. Increasing the current can increase the DAC dynamic range by up to 1.5 dB.

7.3.4.6 Analog Output Common-mode Adjustment

The output common-mode voltage and output range of the analog output are determined by an internal band-gap reference, in contrast to other codecs that can use a scaled version of the analog supply. This scheme is used to reduce noise coupling that can be on the supply (such as 217-Hz noise in a GSM cell phone) into the audio signal path.

However, because of the possible wide variation in analog supply range (2.7 V–3.6 V), an output common-mode voltage setting of 1.35 V, which is used for a 2.7-V supply case, is overly conservative if the supply is much larger (such as 3.3 V or 3.6 V). In order to optimize device operation, the TLV320AIC3109-Q1 includes a programmable output common-mode level that can be set by register programming to a level most appropriate to the actual supply range used by a particular customer. The output common-mode level can be varied among four different values, ranging from 1.35 V (most appropriate for low supply ranges, near 2.7 V) to 1.8 V (most appropriate for high supply ranges, near 3.6 V). As described in [Table 5](#), the recommended DVDD voltage is dependent on the CM setting.

Table 5. Appropriate Settings

CM SETTING	RECOMMENDED AVDD, DRVDD	RECOMMENDED DVDD
1.35 V	2.7 V–3.6 V	1.525 V–1.95 V
1.5 V	3 V–3.6 V	1.65 V–1.95 V
1.65 V	3.3 V–3.6 V	1.8 V–1.95 V
1.8 V	3.6 V	1.95 V

7.3.5 Audio Analog Inputs

The TLV320AIC3109-Q1 includes two single-ended audio inputs. These pins connect through series resistors and switches to the virtual ground pins of two fully differential operational amplifiers. By selecting to turn on only one set of switches per operational amplifier at a time, the inputs can be multiplexed effectively to the PGA.

By selecting to turn on multiple sets of switches per operational amplifier at a time, mixing can also be achieved. Mixing of multiple inputs can easily lead to PGA outputs that exceed the range of the internal operational amplifiers, resulting in saturation and clipping of the mixed output signal. Whenever mixing is being implemented, take adequate precautions to avoid such saturation from occurring. In general, the mixed signal should not exceed $2 V_{PP}$ (single-ended).

In most mixing applications, there is also a general need to adjust the levels of the individual signals being mixed. For example, if a soft signal and a large signal are to be mixed and played together, the soft signal generally should be amplified to a level comparable to the large signal before mixing. In order to accommodate this need, the TLV320AIC3109-Q1 includes input level controls on each of the individual inputs before being mixed or multiplexed into the ADC PGA, with gain programmable from 0 dB to –12 dB in 1.5-dB steps. This input level control is not intended to be a volume control, but instead used occasionally for level setting. Soft-stepping of the input level control settings is implemented in this device, with the speed and functionality following the settings used by the ADC PGA for soft-stepping.

Figure 20 shows the single-ended mixing configuration for the PGA, which enables mixing of the signals LINE1L and LINE1R. The PGA MIX is similar, enabling mixing of the LINE1R and LINE1L signals.

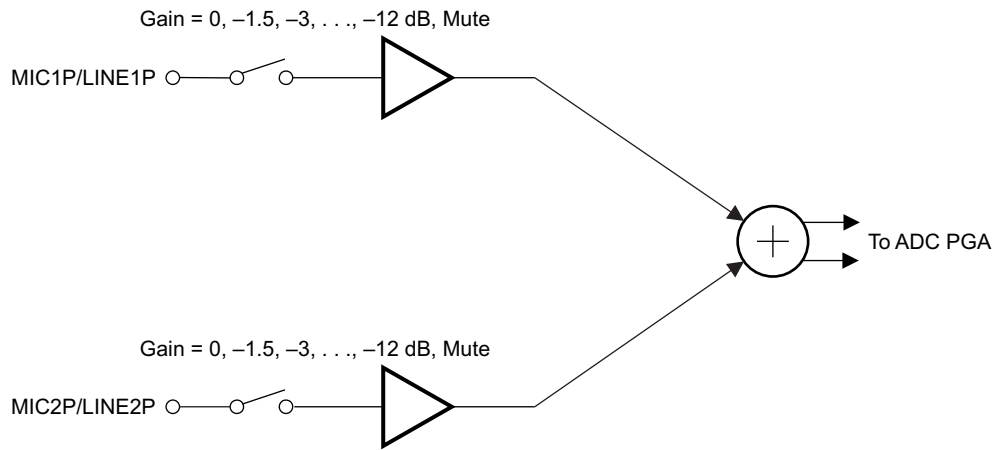

Figure 20. Single-Ended Analog Input Mixing Configuration

7.3.6 Analog Fully Differential Line Output Drivers

The TLV320AIC3109-Q1 has two fully differential line output drivers, each capable of driving a 10-kΩ differential load. Figure 21 and Figure 22 illustrate the output stage design leading to the fully differential line output drivers. This design includes extensive capability to adjust signal levels independently before any mixing occurs, beyond that already provided by the PGA gain and the DAC digital volume control.

The PGA signal refers to the output of the ADC PGA stage that is passed around the ADC to the output stage. PGA_AUX is the output of the auxiliary PGA. The DAC output can be sent to the output driver and mixed with the PGA or PGA_AUX signal. Undesired signals can also be disconnected from the MIX through register control.

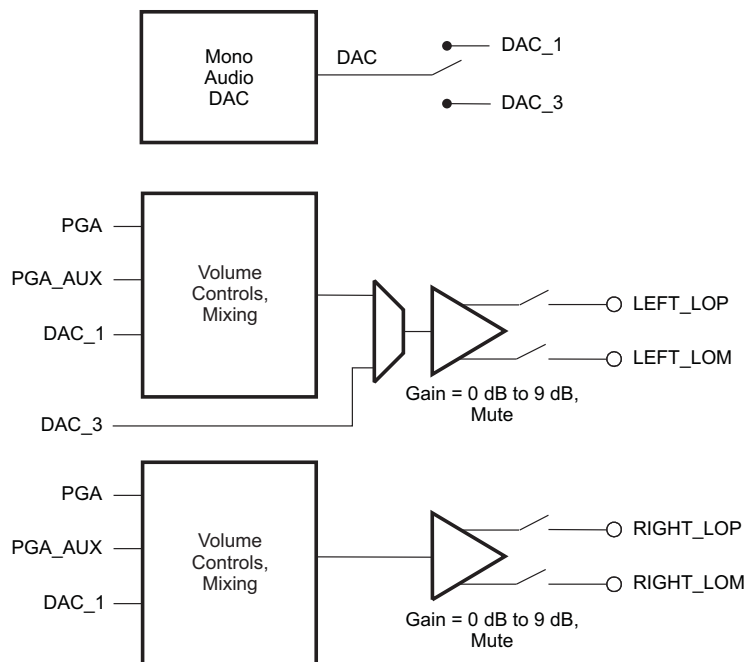

Figure 21. Architecture of the Output Stage Leading to the Fully Differential Line Output Drivers

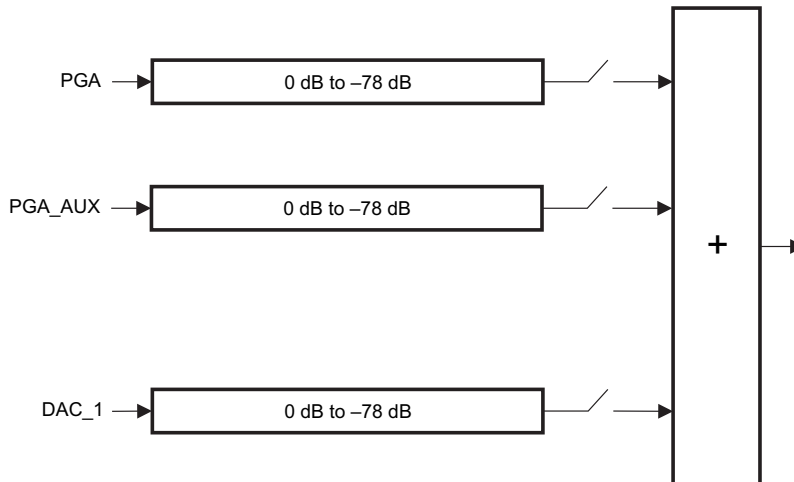

Figure 22. Detail of the Volume Control and Mixing Function in [Figure 19](#) and [Figure 29](#)

The DAC signal is the output of the mono audio DAC that can be steered by register control based on the requirements of the system. If mixing of the DAC audio with other signals is not required, and the DAC output is only needed at the mono line outputs, then use the routing through the DAC_3 path to the fully differential line outputs. This configuration results in lower-power operation because the analog volume controls and mixing blocks ahead of these drivers can be powered down.

If instead the DAC analog output must be routed to multiple output drivers simultaneously (such as to LEFT_LOP, LEFT_LOM and RIGHT_LOP, RIGHT_LOM) or must be mixed with other analog signals, then switch the DAC outputs through the DAC_1 path. This option provides the maximum flexibility for routing of the DAC analog signals to the output drivers.

The TLV320AIC3109-Q1 includes an output level control on each output driver with limited gain adjustment from 0 dB to 9 dB. The output driver circuitry in this device is designed to provide a low-distortion output when playing full-scale mono DAC signals at a 0-dB gain setting. However, a higher amplitude output can be obtained at the cost of increased signal distortion at the output. This output level control allows this tradeoff to be made based on the requirements of the end equipment. This output level control is not intended to be used as a standard output volume control, but is expected to be used only sparingly for level setting (that is, for adjustment of the full-scale output range of the device).

Each differential line output driver can be powered down independently of the others when not needed in the system. When placed into powerdown through register programming, the driver output pins are placed into a high-impedance state.

7.3.7 Analog High-Power Output Drivers

The TLV320AIC3109-Q1 includes two high-power output drivers with extensive flexibility in their usage. These output drivers are individually capable of driving 30 mW each into a 16-Ω load in single-ended configuration, and can be used in pairs connected in a bridge-terminated load (BTL) configuration between two driver outputs.

The high-power output drivers can be configured in a variety of ways, including:

1. Driving up to two single-ended output signals
2. Driving one single-ended output signal, with the remaining driver driving a fixed VCM level

The output stage architecture leading to the high-power output drivers is provided in [Figure 23](#), with the volume control and mixing blocks being effectively identical to those in [Figure 22](#). Each of these drivers has an output level control block like those included with the line output drivers, allowing gain adjustment up to 9 dB on the output signal. As in the previous case, this output level adjustment is not intended to be used as a standard volume control, but instead is included for additional full-scale output signal-level control.

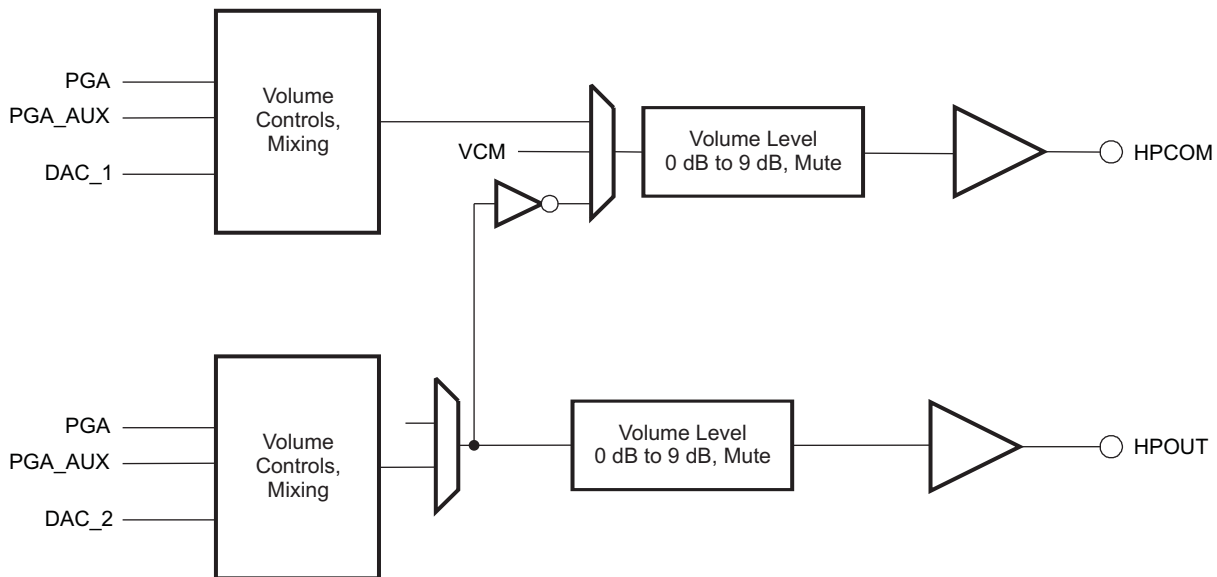

Figure 23. Architecture of the Output Stage Leading to the High-Power Output Drivers

The high-power output drivers include additional circuitry to avoid artifacts on the audio output during power-on and power-off transient conditions. First program the type of output configuration being used in register 14, page 0 to allow the device to select the optimal power-up scheme to avoid output artifacts. The power-up delay time for the high-power output drivers is also programmable over a wide range of time delays, from instantaneous up to 4 s, using register 42, page 0.

When powered down, place these output drivers into a variety of output conditions based on register programming. If lowest-power operation is desired, then the outputs can be placed into a high-impedance state and all power to the output stage is removed. However, this generally results in the output nodes drifting to rest near the upper or lower analog supply because of small leakage currents at the pins, which then results in a longer delay requirement to avoid output artifacts during driver power-on. In order to reduce this required power-on delay, the TLV320AIC3109-Q1 includes an option for the output pins of the drivers to be weakly driven to the VCM level that the pins normally rest at when powered with no signal applied. This output VCM level is determined by an internal band-gap voltage reference, and thus results in extra power dissipation when the drivers are in power down. However, this option provides the fastest method for transitioning the drivers from power-down to full-power operation without any output artifact introduced.

The device includes a further option that falls between the other two—although less power is required when the output drivers are in power down, a slightly longer delay is required to power up without artifacts than if the band-gap reference is kept alive. In this alternate mode, the powered-down output driver pin is weakly driven to a voltage of approximately half the DRVDD supply level using an internal voltage divider. This voltage does not match the actual VCM of a fully powered driver, but because of the output voltage being close to the final value, a much shorter power-up delay time setting can be used and still avoid any audible output artifacts. These output voltage options are controlled in page 0, register 42.

The high-power output drivers can also be programmed to power up first with the output level (gain) control in a highly attenuated state; then the output driver automatically reduces the output attenuation slowly to reach the programmed output gain. This capability is enabled by default but can be enabled in register 40, page 0.

7.3.8 Output Stage Volume Controls

A basic analog volume control with a range from 0 dB to -78 dB and mute is replicated multiple times in the output stage network, connected to each of the analog signals that route to the output stage. In addition, to enable completely independent mixing operations to be performed for each output driver, each analog signal coming into the output stage can have up to seven separate volume controls. These volume controls all have approximately 0.5-dB step programmability over most of the gain range, with steps increasing slightly at the lowest attenuations. [Table 6](#) lists the detailed gain versus programmed setting for this basic volume control.

Table 6. Output Stage Volume Control Settings and Gains

GAIN SETTING	ANALOG GAIN (dB)	GAIN SETTING	ANALOG GAIN (dB)	GAIN SETTING	ANALOG GAIN (dB)	GAIN SETTING	ANALOG GAIN (dB)
0	0	30	-15	60	-30.1	90	-45.2
1	-0.5	31	-15.5	61	-30.6	91	-45.8
2	-1	32	-16	62	-31.1	92	-46.2
3	-1.5	33	-16.5	63	-31.6	93	-46.7
4	-2	34	-17	64	-32.1	94	-47.4
5	-2.5	35	-17.5	65	-32.6	95	-47.9
6	-3	36	-18	66	-33.1	96	-48.2
7	-3.5	37	-18.6	67	-33.6	97	-48.7
8	-4	38	-19.1	68	-34.1	98	-49.3
9	-4.5	39	-19.6	69	-34.6	99	-50
10	-5	40	-20.1	70	-35.1	100	-50.3
11	-5.5	41	-20.6	71	-35.7	101	-51
12	-6	42	-21.1	72	-36.1	102	-51.4
13	-6.5	43	-21.6	73	-36.7	103	-51.8
14	-7	44	-22.1	74	-37.1	104	-52.2
15	-7.5	45	-22.6	75	-37.7	105	-52.7
16	-8	46	-23.1	76	-38.2	106	-53.7
17	-8.5	47	-23.6	77	-38.7	107	-54.2
18	-9	48	-24.1	78	-39.2	108	-55.3
19	-9.5	49	-24.6	79	-39.7	109	-56.7
20	-10	50	-25.1	80	-40.2	110	-58.3
21	-10.5	51	-25.6	81	-40.7	111	-60.2
22	-11	52	-26.1	82	-41.2	112	-62.7
23	-11.5	53	-26.6	83	-41.7	113	-64.3
24	-12	54	-27.1	84	-42.2	114	-66.2
25	-12.5	55	-27.6	85	-42.7	115	-68.7
26	-13	56	-28.1	86	-43.2	116	-72.2
27	-13.5	57	-28.6	87	-43.8	117	-78.3
28	-14	58	-29.1	88	-44.3	118-127	Mute
29	-14.5	59	-29.6	89	-44.8	—	—

7.3.9 Input Impedance and VCM Control

The TLV320AIC3109-Q1 includes several programmable settings to control analog input pins, particularly when these inputs are not selected for connection to a PGA. The default option allows unselected inputs to be put into a high-impedance state such that the input impedance of the device is extremely high. However, the pins on the device do include protection diode circuits connected to AVDD and AVSS. Thus, if any voltage is driven onto a pin approximately one diode drop (~0.6 V) above AVDD or one diode drop below AVSS, these protection diodes begin conducting current, resulting in an effective impedance that no longer appears as a high-impedance state.

In most cases, ac-couple the analog input pins on the TLV320AIC3109-Q1 to the analog input sources, except if an ADC is used for dc voltage measurement. The ac-coupling capacitor causes a high-pass filter pole to be inserted into the analog signal path, so the size of the capacitor must be chosen to move that filter pole sufficiently low in frequency to cause minimal effect on the processed analog signal. The input impedance of the analog inputs when selected for connection to a PGA varies with the setting of the input level control, starting at approximately 20 kΩ with an input level control setting of 0 dB, and increasing to approximately 80 kΩ when the input level control is set at -12 dB. For example, using a 0.1-μF ac-coupling capacitor at an analog input results in a high-pass filter pole of 80 Hz when the 0-dB input level control setting is selected.

7.3.10 MICBIAS Generation

The TLV320AIC3109-Q1 includes a programmable microphone bias output voltage (MICBIAS), capable of providing output voltages of 2 V or 2.5 V (both derived from the on-chip, band-gap voltage) with a 4-mA output current drive. In addition, the MICBIAS can be programmed to be connected to AVDD directly through an on-chip switch, or powered down completely when not needed for power savings. This function is controlled by register programming in register 25, page 0.

7.3.11 Short-Circuit Output Protection

The TLV320AIC3109-Q1 includes programmable short-circuit protection for the high-power output drivers for maximum flexibility in a given application. By default, if shorted, these output drivers automatically limit the maximum amount of current that can be sourced to or sunk from a load, thereby protecting the device from an overcurrent condition. In this mode, register 95, page 0 can be read to determine whether the device is in short-circuit protection or not, and then the device can be programmed to power-down the output drivers if needed. However, the device includes further capability to power-down an output driver automatically whenever the driver goes into short-circuit protection without requiring user intervention. In this case, the output driver remains in a power-down condition until specifically programmed to power down and then power back up again to clear the short-circuit flag.

7.3.12 Jack and Headset Detection

The TLV320AIC3109-Q1 includes extensive capability to monitor a headphone, microphone, or headset jack, determine if a plug has been inserted into the jack, and then determine what type of headset or headphone is wired to the plug. [Figure 24](#) shows one configuration of the device that enables detection and determination of headset type when a pseudo-differential (capacitor free) mono headphone output configuration is used. The registers used for this function are registers 14, 96, 97, and 13, page 0. The type of headset detected can be read back from register 13, page 0. For best results, select a MICBIAS value as high as possible and program the output driver common-mode level at a 1.35-V or 1.5-V level.

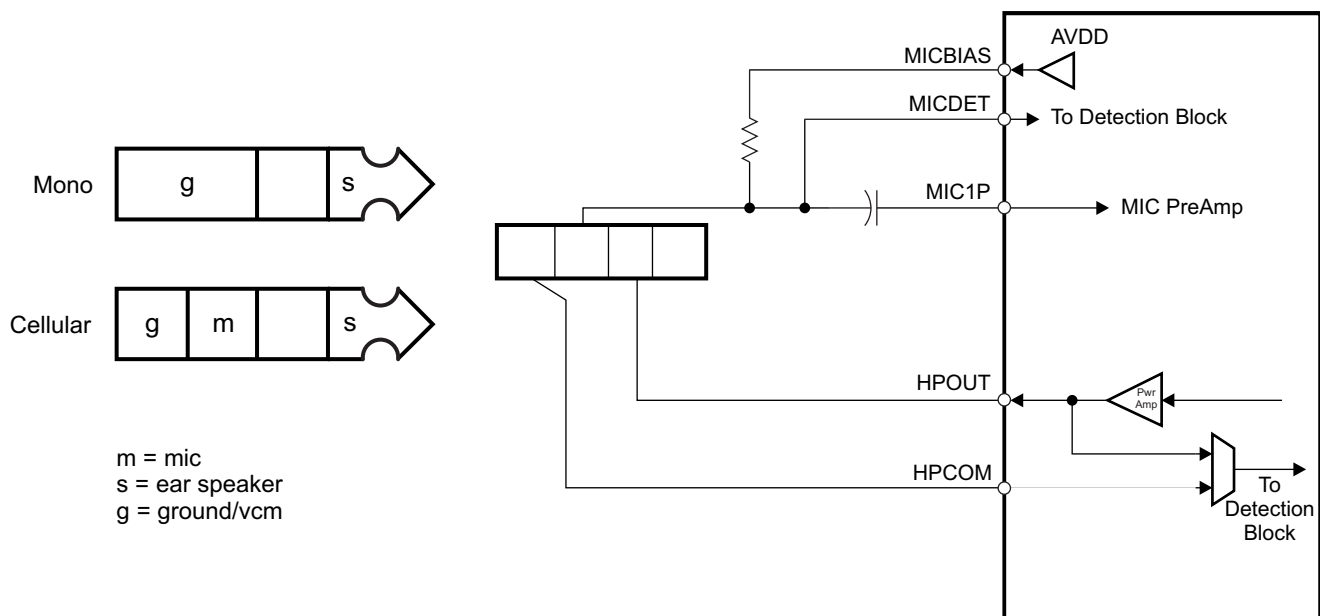

Figure 24. Configuration of Device for Jack Detection Using a Pseudo-Differential (Capacitor Free) Headphone Output Connection

Figure 25 shows a modified output configuration used when the output drivers are ac-coupled.

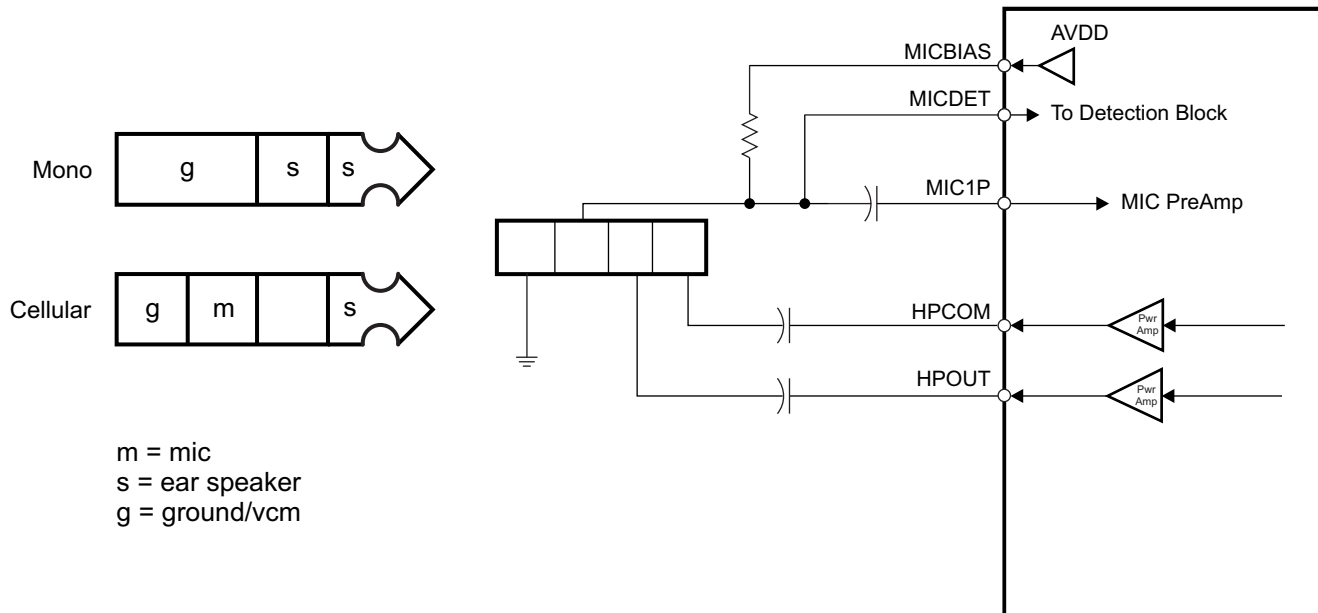

Figure 25. Configuration of Device for Jack Detection Using an AC-Coupled Mono Headphone Output Connection

7.4 Device Functional Modes

7.4.1 Bypass Path Mode

The TLV320AIC3109-Q1 is a versatile device designed for low-power applications. In some cases, only a few features of the device are required. For these applications, the unused stages of the device must be powered down to save power and use an alternate route. This path is called a bypass path. The bypass path modes let the device save power by turning off unused stages (such as the ADC, DAC, and PGA).

7.4.1.1 ADC PGA Signal Bypass Path Functionality

In addition to the input bypass path described previously, the TLV320AIC3109-Q1 also includes the ability to route the ADC PGA output signals past the ADC for mixing with other analog signals and then for direct connection to the output drivers. These bypass functions are described in more detail in the [Analog Fully Differential Line Output Drivers](#) and [Analog High-Power Output Drivers](#) sections.

Device Functional Modes (continued)

7.4.1.2 Passive Analog Bypass During Power Down

Programming the TLV320AIC3109-Q1 to passive analog bypass occurs by configuring the output stage switches for passthrough. [Figure 26](#) shows that this process is done by opening switches SW-L0, SW-L3, SW-R0, and SW-R3 and closing either SW-L1 and SW-R1. Programming this mode is done by writing to register 108, page 0.

Connecting the MIC1P/LINE1P input signal to the LEFT_LOP pin is done by closing SW-L1 and opening SW-L0; this action is done by writing a 1 to bit 0 in register 108, page 0. Connecting the MIC1M/LINE1M input signal to the LEFT_LOM pin is done by closing SW-L4 and opening SW-L3; this action is done by writing a 1 to bit 1 in register 108, page 0.

Connecting the MIC2P/LINE2P input signal to the RIGHT_LOP pin is done by closing SW-R1 and opening SW-R0; this action is done by writing a 1 to bit 4 in register 108, page 0. [Figure 26](#) shows a diagram of the passive analog bypass mode configuration.

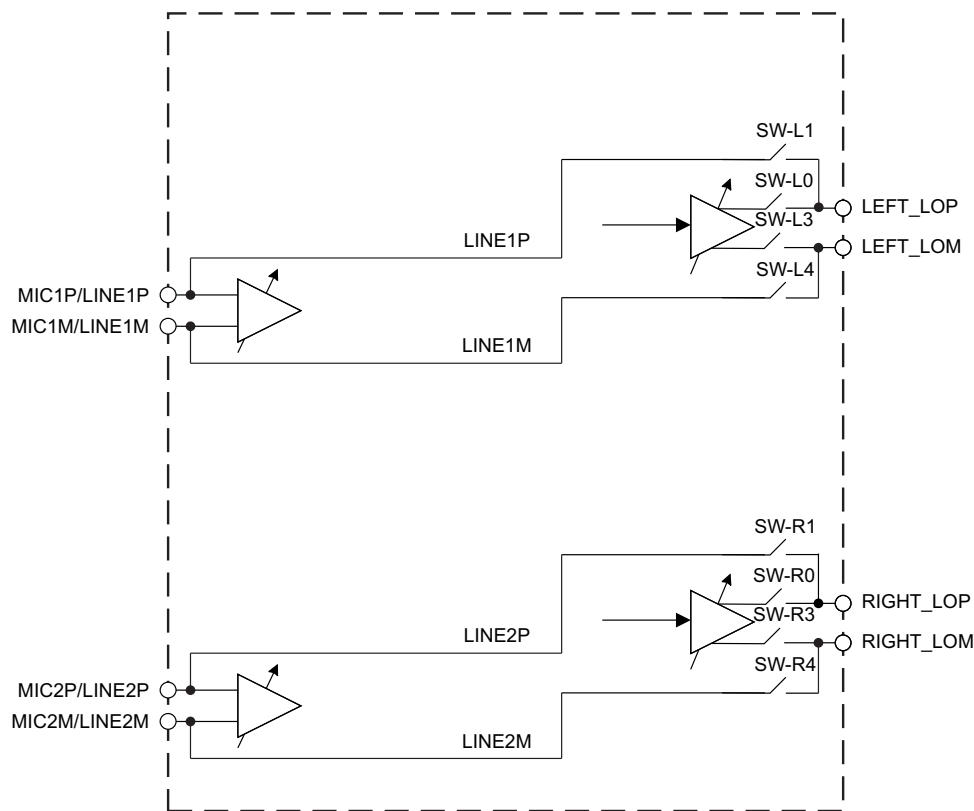

B0174-01

Figure 26. Passive Analog Bypass Mode Configuration

Device Functional Modes (continued)

7.4.2 Digital Audio Processing for Record Path

In applications where record-only is selected and the DAC is powered down, the playback path signal processing blocks can be used in the ADC record path. These filtering blocks can support high-pass, low-pass, band-pass, or notch filtering. In this mode, the record-only path has switches SW-D1 and SW-D2 closed, and reroutes the ADC output data through the digital signal processing blocks. Because the DAC digital signal processing blocks are being re-used, naturally the addresses of these digital filter coefficients are the same as for the DAC digital processing and are located in registers 1–26, page 1. This record-only mode is enabled by powering down the DAC by writing to bit 7 in register 37, page 0 (where bit 7 = 0). Next, enable the digital filter pathway for the ADC by writing a 1 to bit 3 in register 107, page 0. (This pathway is only enabled if the DAC is powered down.) Figure 27 shows the record-only path.

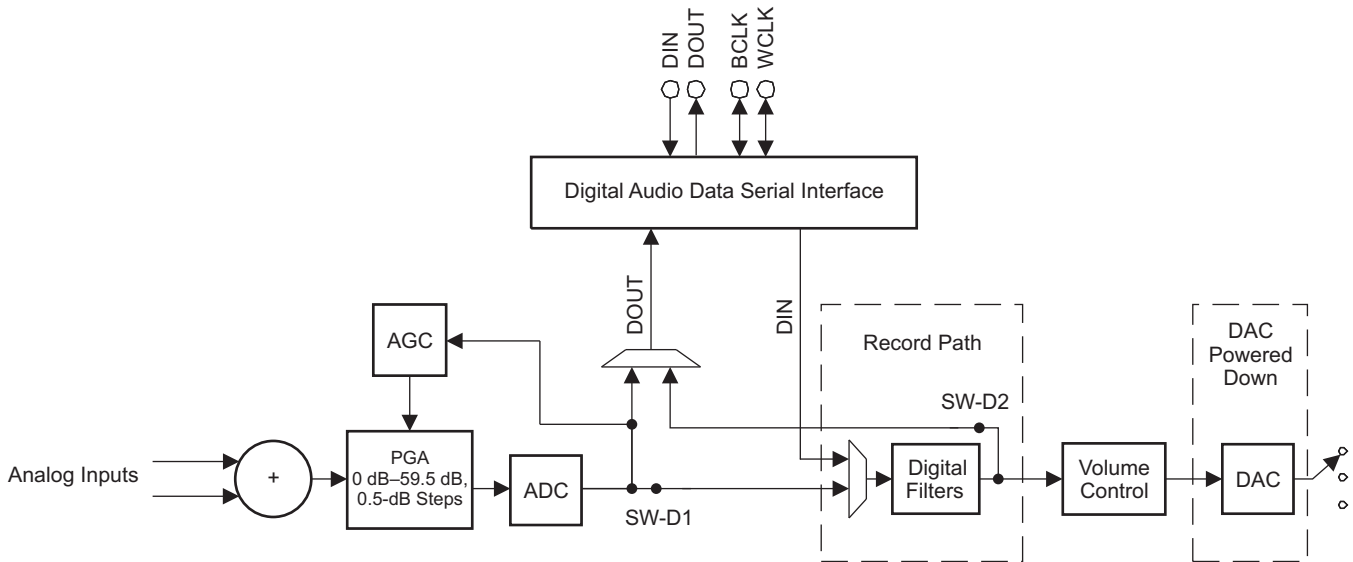

B0173-01

Figure 27. Record-Only Mode With Digital Processing Path Enabled

7.5 Programming

7.5.1 I²C Control Interface

The TLV320AIC3109-Q1 supports the I²C control protocol using 7-bit addressing and is capable of both standard and fast modes. As illustrated in Figure 28, the minimum timing for each t_{HD-STA} , t_{SU-STA} , and t_{SU-STO} is 0.9 μ s for I²C fast mode. The TLV320AIC3109-Q1 responds to the I²C address of 001 1000. I²C is a two-wire, open-drain interface supporting multiple devices and masters on a single bus. Devices on the I²C bus only drive the bus lines low by connecting the lines to ground; the devices never drive the bus lines high. Instead, the bus wires are pulled high by pullup resistors so the bus wires are high when not being driven low by a device. This way two devices cannot conflict; if two devices drive the bus simultaneously, there is no driver contention.

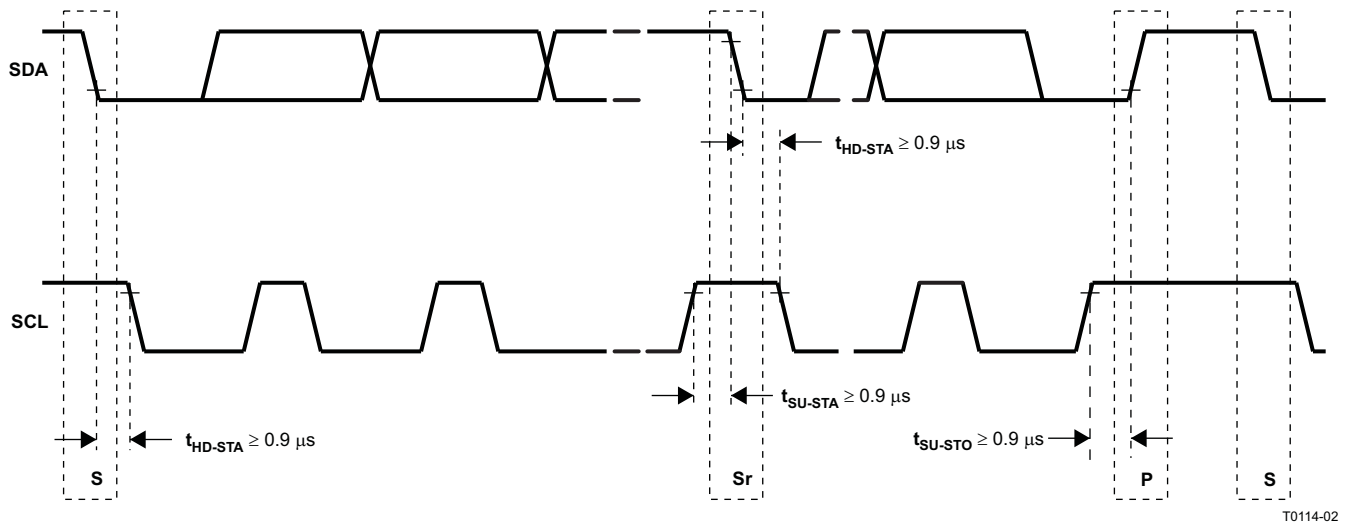

Figure 28. I²C Interface Timing

Communication on the I²C bus always takes place between two devices, one acting as the master and the other acting as the slave. Both masters and slaves can read and write, but slaves can only do so under the direction of the master. Some I²C devices can act as masters or slaves, but the TLV320AIC3109-Q1 can only act as a slave device.

An I²C bus consists of two lines, SDA and SCL. SDA carries data; SCL provides the clock. All data are transmitted across the I²C bus in groups of eight bits. To send a bit on the I²C bus, the SDA line is driven to the appropriate level when SCL is low (a low on SDA indicates the bit is zero; a high indicates the bit is one). When the SDA line settles, the SCL line is brought high then low. This pulse on SCL clocks the SDA bit into the receiver shift register.

The I²C bus is bidirectional: the SDA line is used both for transmitting and receiving data. When a master reads from a slave, the slave drives the data line; when a master sends to a slave, the master drives the data line. Under normal circumstances the master drives the clock line.

Most of the time the bus is idle, no communication is taking place, and both lines are high. When communication is taking place, the bus is active. Only master devices can start a communication by causing a START condition on the bus. Normally, the data line is only allowed to change state when the clock line is low. If the data line changes state when the clock line is high, then the data line state is either a START condition or a STOP condition. A START condition is when the clock line is high and the data line goes from high to low. A STOP condition is when the clock line is high and the data line goes from low to high.

After the master issues a START condition, the master sends a byte that indicates which slave device to communicate with. This byte is called the *address* byte. Each device on an I²C bus has a unique 7-bit address. (Slaves can also have 10-bit addresses; see the I²C specification for details.) The master sends an address in the address byte with a bit indicating whether to read from or write to the slave device.

Programming (continued)

Every byte transmitted on the I²C bus, address or data, is acknowledged with an acknowledge bit. When a master finishes sending a byte (eight data bits) to a slave, the master stops driving SDA and waits for the slave to acknowledge the byte. The slave acknowledges the byte by pulling SDA low. The master then sends a clock pulse to clock the acknowledge bit. Similarly, when a master finishes reading a byte, the master pulls SDA low to acknowledge this operation to the slave. The master then sends a clock pulse to clock the bit.

A not-acknowledge is performed by simply leaving SDA high during an acknowledge cycle. If a device is not present on the bus and the master attempts to address the device, the master receives a not-acknowledge because no device is present at that address to pull the line low.

When a master finishes communicating with a slave, the master can issue a STOP condition. When a STOP condition is issued, the bus becomes idle again. A master can also issue another START condition. When a START condition is issued when the bus is active, this condition is called a *repeated START* condition.

The TLV320AIC3109-Q1 also responds to and acknowledges a general call, which consists of the master issuing a command with a slave-address byte of 00h. [Figure 29](#) and [Figure 30](#) show timing diagrams for I²C write and read operations, respectively.

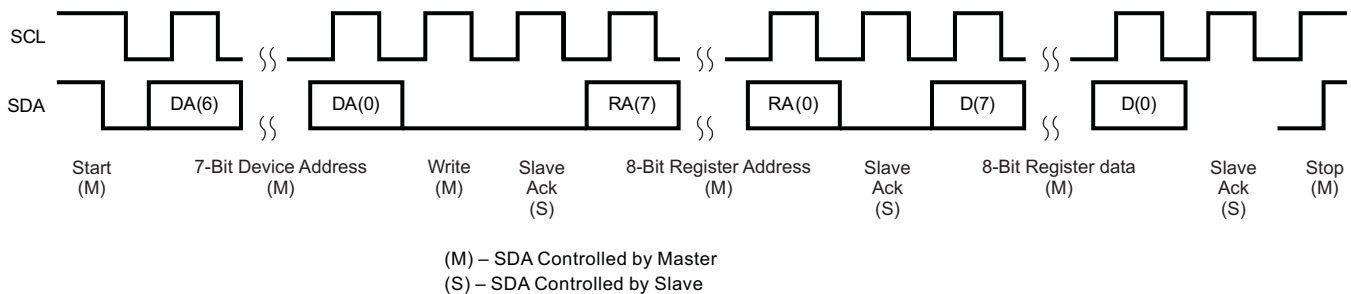

T0147-01

Figure 29. I²C Write

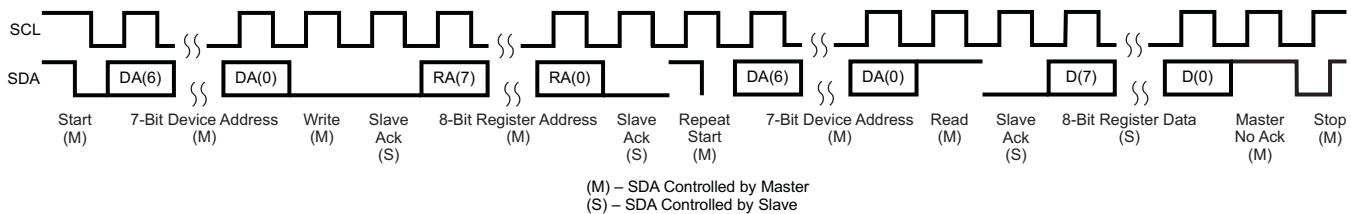

T0148-01

Figure 30. I²C Read

In the case of an I²C register write, if the master does not issue a STOP condition, then the device enters auto-increment mode. So in the next eight clocks, the data on SDA are treated as data for the next incremental register.

Similarly, in the case of an I²C register read, after the device has sent out the 8-bit data from the addressed register, if the master issues an acknowledge, the slave takes over control of the SDA bus and transmits for the next 8 clocks the data of the next incremental register.

7.5.1.1 I²C Bus Debug in a Glitched System

Occasionally, some systems can encounter noise or glitches on the I²C bus. In the unlikely event that this noise affects bus performance, use the I²C debug register. This feature terminates the I²C bus error allowing the I²C device and system to resume communications. The I²C bus error detector is enabled by default. The TLV320AIC3109-Q1 I²C error detector status can be read from bit 0 in register 107, page 0. If desired, the detector can be disabled by writing to bit 2 in register 107, page 0.

7.6 Register Maps

7.6.1 Register Map Structure

The register map of the TLV320AIC3109-Q1 consists of two pages of registers, with each page containing 128 registers. The register at address zero on each page is used as a page-control register and writing to this register determines the active page for the device. All subsequent read/write operations access the page that is active at the time unless a register write is performed to change the active page. The active page defaults to page 0 on device reset.

[Table 7](#) lists the different access codes used in the TLV320AIC3109-Q1 registers.

Table 7. TLV320AIC3109-Q1 Access Type Codes

Access Type	Code	Description
R	R	Read
R-W	R/W	Read or write
W	W	Write
-n		Value after reset or the default value

The control registers for the TLV320AIC3109-Q1 are described in this section. All registers are 8 bits in width, with bit 7 referring to the most-significant bit of each register and bit 0 referring to the least-significant bit. [Table 8](#) lists the registers for page 0 and page 1.

Table 8. TLV320AIC3109-Q1 Register Map

REGISTER	REGISTER DATA							
	7	6	5	4	3	2	1	0
PAGE 0 REGISTERS								
Register 0	0	0	0	0	0	0	Page Select	
Register 1	Software Reset	0	0	0	0	0	0	0
Register 2	ADC Sample Rate Select				DAC Sample Rate Select			
Register 3	PLL Q	PLL Q			PLL P			
Register 4	PLL J						0	0
Register 5	PLL D							
Register 6	PLL D						0	0
Register 7	$f_{S(ref)}$ Setting	DAC Dual-Rate Control	DAC Data Path Control	DAC Data Path Control		0	0	0
Register 8	Word Clock Directional Control	Serial Output Data Driver	Bit, Word Clock Drive Control	Bit, Word Clock Drive Control	0	0	0	0
Register 9	Audio Serial Data Interface Transfer Mode		Bit Clock Rate Control		Bit Clock Rate Control	ADC Re-Sync	Re-Sync Mute Behavior	Re-Sync Mute Behavior
Register 10	Audio Serial Data Word Offset Control							
Register 11	ADC Overflow Flag	0	DAC Overflow Flag	0	PLL R			
Register 12	ADC High-Pass Filter Control		0	0	DAC De-Emphasis Filter Control	DAC De-Emphasis Filter Control	0	0
Register 13	Headset Detection Control	Headset Type Detection Results		Headset Glitch Suppression Debounce Control for Button Press			Headset Glitch Suppression Debounce Control for Button Press	
Register 14	Driver Capacitive Coupling	0	0	Headset Detection Flag	0	0	0	0
Register 15	ADC PGA Mute	ADC PGA Gain Setting						
Register 16	PGA_AUX Mute	PGA_AUX Gain Setting						
Register 19	MIC1P/LINE1P Input Level Control for ADC PGA Mix	MIC1P/LINE1P Input Level Control for ADC PGA Mix				ADC PGA Soft-Stepping Control	ADC PGA Soft-Stepping Control	
Register 21	MIC2P/LINE2P Input Level Control for ADC PGA Mix	MIC2P/LINE2P Input Level Control for ADC PGA Mix				0	0	0
Register 25	MICBIAS Level Control		0	0	0	0	0	0
Register 26	AGC Enable	AGC Attack Time			AGC Decay Time		AGC Decay Time	
Register 27	AGC Maximum Gain Allowed							0
Register 28	Noise Gate Hysteresis Level Control		AGC Clip Stepping Control					AGC Clip Stepping Control
Register 32	Channel Gain Applied by AGC Algorithm							
Register 34	AGC Noise Detection Debounce Control				AGC Signal Detection Debounce Control			
Register 36	ADC PGA Status	ADC Power Status	AGC Signal Detection Status	AGC Saturation Flag	0	0	0	0
Register 37	DAC Power Control	0	0	0	0	0	0	0

Table 8. TLV320AIC3109-Q1 Register Map (continued)

REGISTER	REGISTER DATA							
	7	6	5	4	3	2	1	0
Register 38	0	0	HPCOM Output Driver Configuration Control			Short-Circuit Protection Control	Short-Circuit Protection Mode Control	0
Register 40	Output Common-Mode Voltage Control		0	0	0	0	Output Volume Control Soft-Stepping	
Register 41	DAC Output Switching Control		0	0	0	0	0	0
Register 42	Output Driver Power-On Delay Control				Driver Ramp-Up Step Timing Control		Weak Output Common-Mode Voltage Control	0
Register 43	DAC Digital Mute	DAC Digital Volume Control Setting						
Register 60	PGA Output Routing Control	PGA to HPOUT Analog Volume Control						
Register 61	DAC_1 Output Routing Control	DAC_1 to HPOUT Analog Volume Control						
Register 63	PGA_AUX Output Routing Control	PGA_AUX to HPOUT Analog Volume Control						
Register 65	HPOUT Output Level Control				HPOUT Mute	HPOUT Power-Down Drive Control	HPOUT Volume Control Status	HPOUT Power Control
Register 67	PGA Output Routing Control	PGA to HPCOM Analog Volume Control						
Register 68	DAC_1 Output Routing Control	DAC_1 to HPCOM Analog Volume Control						
Register 70	PGA_AUX Output Routing Control	PGA_AUX to HPCOM Analog Volume Control						
Register 72	HPCOM Output Level Control				HPCOM Mute	HPCOM Volume Control Status	HPCOM Volume Control Status	HPCOM Power Control
Register 81	PGA Output Routing Control	PGA to LEFT_LOP/M Analog Volume Control						
Register 82	DAC_1 Output Routing Control	DAC_1 to LEFT_LOP/M Analog Volume Control						
Register 84	PGA_AUX Output Routing Control	PGA_AUX to LEFT_LOP/M Analog Volume Control						
Register 86	LEFT_LOP/M Output Level Control				LEFT_LOP/M Mute	0	LEFT_LOP/M Volume Control Status	LEFT_LOP/M Power Status
Register 88	PGA Output Routing Control	DAC_1 Output Routing Control						
Register 89	DAC_1 Output Routing Control	DAC_1 to RIGHT_LOP/M Analog Volume Control						
Register 91	PGA_AUX Output Routing Control	PGA_AUX to RIGHT_LOP/M Analog Volume Control						
Register 93	RIGHT_LOP/M Output Level Control				RIGHT_LOP/M Mute	0	RIGHT_LOP/M Volume Control Status	RIGHT_LOP/M Power Status

Table 8. TLV320AIC3109-Q1 Register Map (continued)

REGISTER	REGISTER DATA							
	7	6	5	4	3	2	1	0
Register 94	DAC Power Status	0	0	LEFT_LOP/M Power Status	RIGHT_LOP/M Power Status	0	HPOUT Driver Power Status	0
Register 95	0	HPOUT Short- Circuit Detection Status	0	HPCOM Short- Circuit Detection Status	0	HPCOM Power Status	0	0
Register 96	0	HPOUT Short- Circuit Detection Status	0	HPCOM Short- Circuit Detection Status	0	Headset Detection Status	ADC AGC Noise Gate Status	0
Register 97	0	HPOUT Short- Circuit Detection Status	0	HPCOM Short- Circuit Detection Status	0	Headset Detection Status	ADC AGC Noise Gate Status	0
Register 101	0	0	0	0	0	0	0	CODEC_CLKIN Source Selection
Register 102	CLKDIV_IN Source Selection		PLLCLK_IN Source Selection		0	0	1	0
Register 103	Attack Time Register Selection	Baseline AGC Attack Time		Multiplication Factor for Baseline AGC			0	0
Register 104	Decay Time Register Selection	Baseline AGC Decay Time		Multiplication Factor for Baseline AGC			0	0
Register 107	Channel High- Pass Filter Coefficient Selection	0	0	0	ADC Digital Output to Programmable Filter Path Selection	I ² C Bus Condition Detector	0	I ² C Bus Error Detection Status
Register 108	0	0	LINE1RM Path Selection	LINE1RP Path Selection	0	0	LINE1LM Path Selection	LINE1LP Path Selection
Register 109	DAC Current Adjustment		0	0	0	0	0	0
PAGE 1 REGISTERS								
Register 0	0	0	0	0	0	0	0	Page Select Bit
Register 1	Audio Effects Filter N0 Coefficient MSB							
Register 2	Audio Effects Filter N0 Coefficient LSB							
Register 3	Audio Effects Filter N1 Coefficient MSB							
Register 4	Audio Effects Filter N1 Coefficient LSB							
Register 5	Audio Effects Filter N2 Coefficient MSB							
Register 6	Audio Effects Filter N2 Coefficient LSB							
Register 7	Audio Effects Filter N3 Coefficient MSB							
Register 8	Audio Effects Filter N3 Coefficient LSB							
Register 9	Audio Effects Filter N4 Coefficient MSB							
Register 10	Audio Effects Filter N4 Coefficient LSB							
Register 11	Audio Effects Filter N5 Coefficient MSB							
Register 12	Audio Effects Filter N5 Coefficient LSB							
Register 13	Audio Effects Filter D1 Coefficient MSB							
Register 14	Audio Effects Filter D1 Coefficient LSB							
Register 15	Audio Effects Filter D2 Coefficient MSB							
Register 16	Audio Effects Filter D2 Coefficient LSB							

Table 8. TLV320AIC3109-Q1 Register Map (continued)

REGISTER	REGISTER DATA							
	7	6	5	4	3	2	1	0
Register 17	Audio Effects Filter D4 Coefficient MSB							
Register 18	Audio Effects Filter D4 Coefficient LSB							
Register 19	Audio Effects Filter D5 Coefficient MSB							
Register 20	Audio Effects Filter D5 Coefficient LSB							
Register 21	De-Emphasis Filter N0 Coefficient MSB							
Register 22	De-Emphasis Filter N0 Coefficient LSB							
Register 23	De-Emphasis Filter N1 Coefficient MSB							
Register 24	De-Emphasis Filter N1 Coefficient LSB							
Register 25	De-Emphasis Filter D1 Coefficient MSB							
Register 26	De-Emphasis Filter D1 Coefficient LSB							
Register 65	ADC High-Pass Filter N0 Coefficient MSB							
Register 66	Channel ADC High-Pass Filter N0 Coefficient LSB							
Register 67	Channel ADC High-Pass Filter N1 Coefficient MSB							
Register 68	Channel ADC High-Pass Filter N1 Coefficient LSB							
Register 69	Channel ADC High-Pass Filter D1 Coefficient MSB							
Register 70	Channel ADC High-Pass Filter D1 Coefficient LSB							

7.6.2 Page 0 Registers

These registers are held within page 0.

7.6.2.1 Register 0: Page Select (address = 0h) [reset = 0000 0000], Page 0

Figure 31. Register 0

7	6	5	4	3	2	1	0
0	0	0	0	0	0	0	Page Select
R-0h	R-0h	R-0h	R-0h	R-0h	R-0h	R-0h	R/W-0h

Table 9. Register 0 Field Descriptions

Bit	Field	Type	Reset	Description
7:1	Reserved	R	0h	Reserved. Always write zeros to these bits.
0	Page Select	R/W	0h	Page select bit. Writing a 0 to this bit sets page 0 as the active page for the following register accesses. Writing a 1 to this bit sets page 1 as the active page for the following register accesses. This register bit is recommended to be read back after each write to ensure that the proper page is being accessed for future register reads or writes.

7.6.2.2 Register 1: Software Reset Register (address = 1h) [reset = 0000 0000], Page 0

Figure 32. Register 1

7	6	5	4	3	2	1	0
Software Reset	0	0	0	0	0	0	0
W-0h	W-0h	W-0h	W-0h	W-0h	W-0h	W-0h	W-0h

Table 10. Register 1 Field Descriptions

Bit	Field	Type	Reset	Description
7	Software Reset	W	0h	Software reset bit. 0 : Don't care 1 : Self-clearing software reset
6:0	Reserved	W	0h	Reserved. Always write zeros to these bits.

7.6.2.3 Register 2: Codec Sample Rate Select Register (address = 2h) [reset = 0000 0000], Page 0
Figure 33. Register 2

7	6	5	4	3	2	1	0
ADC Sample Rate Select				DAC Sample Rate Select			
R/W-0h				R/W-0h			

Table 11. Register 2 Field Descriptions

Bit	Field	Type	Reset	Description
7:4	ADC Sample Rate Select ⁽¹⁾	R/W	0h	0000: ADC $f_S = f_{S(\text{ref})} / 1$ 0001: ADC $f_S = f_{S(\text{ref})} / 1.5$ 0010: ADC $f_S = f_{S(\text{ref})} / 2$ 0011: ADC $f_S = f_{S(\text{ref})} / 2.5$ 0100: ADC $f_S = f_{S(\text{ref})} / 3$ 0101: ADC $f_S = f_{S(\text{ref})} / 3.5$ 0110: ADC $f_S = f_{S(\text{ref})} / 4$ 0111: ADC $f_S = f_{S(\text{ref})} / 4.5$ 1000: ADC $f_S = f_{S(\text{ref})} / 5$ 1001: ADC $f_S = f_{S(\text{ref})} / 5.5$ 1010: ADC $f_S = f_{S(\text{ref})} / 6$ 1011–1111: Reserved. Do not write these sequences.
3:0	DAC Sample Rate Select ⁽¹⁾	R/W	0h	0000: DAC $f_S = f_{S(\text{ref})} / 1$ 0001: DAC $f_S = f_{S(\text{ref})} / 1.5$ 0010: DAC $f_S = f_{S(\text{ref})} / 2$ 0011: DAC $f_S = f_{S(\text{ref})} / 2.5$ 0100: DAC $f_S = f_{S(\text{ref})} / 3$ 0101: DAC $f_S = f_{S(\text{ref})} / 3.5$ 0110: DAC $f_S = f_{S(\text{ref})} / 4$ 0111: DAC $f_S = f_{S(\text{ref})} / 4.5$ 1000: DAC $f_S = f_{S(\text{ref})} / 5$ 1001: DAC $f_S = f_{S(\text{ref})} / 5.5$ 1010: DAC $f_S = f_{S(\text{ref})} / 6$ 1011–1111 : Reserved, do not write these sequences.

(1) In the TLV320AIC3109-Q1, the ADC f_S must be set equal to the DAC f_S , which is done by setting the value of bits 7–4 equal to the value of bits 3–0.

7.6.2.4 Register 3: PLL Programming Register A (address = 3h) [reset = 0001 0000], Page 0
Figure 34. Register 3

7	6	5	4	3	2	1	0
PLL	PLL Q				PLL P		
R/W-0h	R/W-0h	R/W-0h	R/W-1h	R/W-0h	R/W-0h		

Table 12. Register 3 Field Descriptions

Bit	Field	Type	Reset	Description
7	PLL		0h	PLL control bit. 0: PLL is disabled 1: PLL is enabled
6:3	PLL Q		0010h	These bits control the PLL Q value. 0000: Q = 16 0001: Q = 17 0010: Q = 2 0011: Q = 3 0100: Q = 4 ... 1110: Q = 14 1111: Q = 15
	PLL P		0h	These bits control the PLL P value. 000: P = 8 001: P = 1 010: P = 2 011: P = 3 100: P = 4 101: P = 5 110: P = 6 111: P = 7

7.6.2.5 Register 4: PLL Programming Register B (address = 4h) [reset = 0000 0100]
Figure 35. Register 4

7	6	5	4	3	2	1	0
PLL J						0	0
R/W-0h	R/W-0h	R/W-0h	R/W-0h	R/W-0h	R/W-1h	R/W-0h	R/W-0h

Table 13. Register 4 Field Descriptions

Bit	Field	Type	Reset	Description
7:2	PLL J	R/W	0000 01h	These bits control the PLL J value. 0000 00: Reserved, do not write this sequence 0000 01: J = 1 0000 10: J = 2 0000 11: J = 3 ... 1111 10: J = 62 1111 11: J = 63
1:0	Reserved	R/W	0h	Reserved. Always write zeros to these bits.

7.6.2.6 Register 5: PLL Programming Register C (address = 5h) [reset = 0000 0000], Page 0
Figure 36. Register 5

7	6	5	4	3	2	1	0
PLL D							
R/W-0h							

Table 14. Register 5 Field Descriptions

Bit	Field	Type	Reset	Description
7:0	PLL D ⁽¹⁾	R/W	0h	These bits control the PLL D value. The eight most-significant bits of a 14-bit unsigned integer valid values for D are from 0 to 9999, represented by a 14-bit integer located in registers 5–6, page 0. Do not write values into these registers that result in a D value outside the valid range.

- (1) Whenever the D value is changed, write register 5 immediately followed by register 6. Even if only the MSB or LSB of the value changes, both registers must be written.

7.6.2.7 Register 6: PLL Programming Register D (address = 6h) [reset = 0000 0000]
Figure 37. Register 6

7	6	5	4	3	2	1	0
PLL D						0	0
R/W-0h						R/W-0h	R/W-0h

Table 15. Register 6 Field Descriptions

Bit	Field	Type	Reset	Description
7:2	PLL D ⁽¹⁾	R/W	0h	These bits control the PLL D value. The six least-significant bits of a 14-bit unsigned integer valid values for D are from 0 to 9999, represented by a 14-bit integer located in registers 5–6, page 0. Do not write values into these registers that result in a D value outside the valid range.
1:0	Reserved	R/W	0h	Reserved. Always write zeros to these bits.

- (1) Whenever the D value is changed, write register 5 immediately followed by register 6. Even if only the MSB or LSB of the value changes, both registers must be written.

7.6.2.8 Register 7: Codec Data-Path Setup Register (address = 7h) [reset = 0000 0000], Page 0
Figure 38. Register 7

7	6	5	4	3	2	1	0
$f_{S(\text{ref})}$ Setting	ADC Dual-Rate Control	DAC Dual-Rate Control	DAC Data Path Control	0	0	0	0
R/W-0h	R/W-0h	R/W-0h	R/W-0h	R/W-0h	R/W-0h	R/W-0h	R/W-0h

Table 16. Register 7 Field Descriptions

Bit	Field	Type	Reset	Description
7	$f_{S(\text{ref})}$ Setting	R/W	0h	This bit controls the $f_{S(\text{ref})}$ setting. This register setting controls timers related to the AGC time constants. 0: $f_{S(\text{ref})} = 48$ kHz 1: $f_{S(\text{ref})} = 44.1$ kHz
6	ADC Dual-Rate Control	R/W	0h	0: ADC dual-rate mode is disabled 1: ADC dual-rate mode is enabled The ADC dual-rate mode must match the DAC dual-rate mode.
5	DAC Dual-Rate Control	R/W	0h	0: DAC dual-rate mode is disabled 1: DAC dual-rate mode is enabled
4:3	DAC Data Path Control	R/W	0h	00: DAC data path is off (muted) 01: DAC data path plays left-channel input data 10: DAC data path plays right-channel input data 11: DAC data path plays mono mix of left- and right-channel input data
2:0	Reserved	R/W	0h	Reserved. Always write zeros to these bits.

7.6.2.9 Register 8: Audio Serial Data Interface Control Register A (address = 8h) [reset = 0000 0000], Page 0
Figure 39. Register 8

7	6	5	4	3	2	1	0
Bit Clock Directional Control	Word Clock Directional Control	Serial Output Data Driver	Bit, Word Clock Drive Control	0	0	0	0
R/W-0h	R/W-0h	R/W-0h	R/W-0h	R-0h	R/W-0h	R/W-0h	R/W-0h

Table 17. Register 8 Field Descriptions

Bit	Field	Type	Reset	Description
7	Bit Clock Directional Control	R/W	0h	Bit clock directional control. 0: BCLK is an input (slave mode) 1: BCLK is an output (master mode)
6	Word Clock Directional Control	R/W	0h	Word clock directional control. 0: WCLK is an input (slave mode) 1: WCLK is an output (master mode)
5	Serial Output Data Driver	R/W	0h	Serial output data driver (DOUT) 3-state control. 0: Do not place DOUT in a high-impedance state when valid data are not being sent 1: Place DOUT in high-impedance state when valid data are not being sent
4	Bit, Word Clock Drive Control	R/W	0h	Bit, word clock drive control. 0: BCLK, WCLK do not continue to be transmitted when running in master mode if the codec is powered down 1: BCLK, WCLK continue to be transmitted when running in master mode, even if the codec is powered down
3	Reserved	R	0h	Reserved. Always write zeros to these bits.
2:0	Reserved	R/W	0h	Reserved. Always write zeros to these bits.

**7.6.2.10 Register 9: Audio Serial Data Interface Control Register B (address = 9h) [reset = 0000 0000],
Page 0**
Figure 40. Register 9

7	6	5	4	3	2	1	0
Audio Serial Data Interface Transfer Mode		Audio Serial Data Word Length Control		Bit Clock Rate Control	DAC Re-Sync	ADC Re-Sync	Re-Sync Mute Behavior
R/W-0h		R/W-0h		R/W-0h	R/W-0h	R/W-0h	R/W-0h

Table 18. Register 9 Field Descriptions

Bit	Field	Type	Reset	Description
7:6	Audio Serial Data Interface Transfer Mode	R/W	0h	Audio serial data interface transfer mode. 00: Serial data bus uses I ² S mode 01: Serial data bus uses DSP mode 10: Serial data bus uses right-justified mode 11: Serial data bus uses left-justified mode
5:4	Audio Serial Data Word Length Control	R/W	0h	Audio serial data word length control. 00: Audio data word length = 16 bits 01: Audio data word length = 20 bits 10: Audio data word length = 24 bits 11: Audio data word length = 32 bits
3	Bit Clock Rate Control	R/W	0h	Bit clock rate control. This register only has effect when the bit clock is programmed as an output. 0: Continuous-transfer mode used to determine master mode bit clock rate 1: 256-clock transfer mode used, resulting in 256 bit clocks per frame
2	DAC Re-Sync	R/W	0h	DAC re-sync. 0: Don't care 1: Re-sync mono DAC with codec interface if the group delay changes by more than \pm DAC ($f_s / 4$)
1	ADC Re-Sync	R/W	0h	ADC re-sync. 0: Don't care 1: Re-sync mono ADC with codec interface if the group delay changes by more than \pm ADC ($f_s / 4$)
0	Re-Sync Mute Behavior	R/W	0h	Re-sync mute behavior. 0: Re-sync is done without soft-muting the channel (ADC or DAC) 1: Re-sync is done by internally soft-muting the channel (ADC or DAC)

7.6.2.11 Register 10: Audio Serial Data Interface Control Register C (address = Ah) [reset = 0000 0000], Page 0
Figure 41. Register 10

7	6	5	4	3	2	1	0
Audio Serial Data Word Offset Control							
R/W-0h							

Table 19. Register 10 Field Descriptions

Bit	Field	Type	Reset	Description
7:0	Audio Serial Data Word Offset Control	R/W	0h	<p>Audio serial data word offset control. This register determines where valid data are placed or expected in each frame by controlling the offset from beginning of the frame where valid data begins. The offset is measured from the rising edge of the word clock when in DSP mode.</p> <p>0000 0000: Data offset = 0 bit clocks 0000 0001: Data offset = 1 bit clock 0000 0010: Data offset = 2 bit clocks ...</p> <p>Note: In continuous transfer mode the maximum offset is 17 for the I²S, left-justified format, and right-justified format modes and 16 for DSP mode. In 256-clock mode, the maximum offset is 242 for the I²S, left-justified format, and right-justified format modes and 241 for DSP modes.</p> <p>1111 1110: Data offset = 254 bit clocks 1111 1111: Data offset = 255 bit clocks</p>

7.6.2.12 Register 11: Audio Codec Overflow Flag Register (address = Bh) [reset = 0000 0001], Page 0
Figure 42. Register 11

7	6	5	4	3	2	1	0
ADC Overflow Flag	0	DAC Overflow Flag	0	PLL R			
R-0h	R-0h	R-0h	R-0h	R/W-0001h			

Table 20. Register 11 Field Descriptions

Bit	Field	Type	Reset	Description
7	ADC Overflow Flag	R	0h	<p>ADC overflow flag. This bit is a sticky bit, which stays set if an overflow occurs, even if the overflow condition is removed. The register bit is reset to 0 after being read.</p> <p>0: No overflow has occurred 1: An overflow has occurred</p>
6	Reserved	R	0h	Reserved. Always write zero to this bit.
5	DAC Overflow Flag	R	0h	<p>DAC overflow flag. This bit is a sticky bit, which stays set if an overflow occurs, even if the overflow condition is removed. The register bit is reset to 0 after being read.</p> <p>0: No overflow has occurred 1: An overflow has occurred</p>
4	Reserved	R	0h	Reserved. Always write zero to this bit.
3:0	PLL R	R/W	0001h	<p>PLL R value.</p> <p>0000: R = 16 0001: R = 1 0010: R = 2 0011: R = 3 0100: R = 4 ...</p> <p>1110: R = 14 1111: R = 15</p>

7.6.2.13 Register 12: Audio Codec Digital Filter Control Register (address = Ch) [reset = 0000 0000], Page 0

Figure 43. Register 12

7	6	5	4	3	2	1	0
ADC High-Pass Filter Control		0	0	DAC Digital Effects Filter Control	DAC De-Emphasis Filter Control	0	0
R/W-0h	R/W-0h	R/W-0h	R/W-0h	R/W-0h	R/W-0h	R/W-0h	R/W-0h

Table 21. Register 12 Field Descriptions

Bit	Field	Type	Reset	Description
7:6	ADC High-Pass Filter Control	R/W	0h	ADC high-pass filter control. 00: ADC high-pass filter disabled 01: ADC high-pass filter –3-dB frequency = 0.0045 × ADC f _S 10: ADC high-pass filter –3-dB frequency = 0.0125 × ADC f _S 11: ADC high-pass filter –3-dB frequency = 0.025 × ADC f _S
5:4	Reserved	R/W	0h	Reserved. Always write zeros to these bits.
3	DAC Digital Effects Filter Control	R/W	0h	DAC digital effects filter control. 0: DAC digital effects filter disabled (bypassed) 1: DAC digital effects filter enabled
2	DAC De-Emphasis Filter Control	R/W	0h	DAC de-emphasis filter control. 0: DAC de-emphasis filter disabled (bypassed) 1: DAC de-emphasis filter enabled
1:0	Reserved	R/W	0h	Reserved. Always write zeros to these bits.

7.6.2.14 Register 13: Headset/Button Press Detection Register A (address = Dh) [reset = 0000 0000], Page 0

Figure 44. Register 13

7	6	5	4	3	2	1	0
Headset Detection Control	Headset Type Detection Results		Headset Glitch Suppression Debounce Control for Jack Detection			Headset Glitch Suppression Debounce Control for Button Press	
R/W-0h	R-0h		R/W-0h			R/W-0h	

Table 22. Register 13 Field Descriptions

Bit	Field	Type	Reset	Description
7	Headset Detection Control	R/W	0h	Headset detection control. 0: Headset detection disabled 1: Headset detection enabled
6:5	Headset Type Detection Results	R	0h	Headset type detection results. 00: No headset detected 01: Headset without microphone detected 10: Ignore (reserved) 11: Headset with microphone detected
4:2	Headset Glitch Suppression Debounce Control for Jack Detection	R/W	0h	Headset glitch suppression debounce control for jack detection. 000: Debounce = 16 ms (sampled with 2-ms clock) 001: Debounce = 32 ms (sampled with 4-ms clock) 010: Debounce = 64 ms (sampled with 8-ms clock) 011: Debounce = 128 ms (sampled with 16-ms clock) 100: Debounce = 256 ms (sampled with 32-ms clock) 101: Debounce = 512 ms (sampled with 64-ms clock) 110, 111: Reserved, do not write this bit sequence to these register bits
1:0	Headset Glitch Suppression Debounce Control for Button Press	R/W	0h	Headset glitch suppression debounce control for button press. 00: Debounce = 0 ms 01: Debounce = 8 ms (sampled with 1-ms clock) 10: Debounce = 16 ms (sampled with 2-ms clock) 11: Debounce = 32 ms (sampled with 4-ms clock)

7.6.2.15 Register 14: Headset/Button Press Detection Register B (address = Eh) [reset = 0000 0000], Page 0
Figure 45. Register 14

7	6	5	4	3	2	1	0
Driver Capacitive Coupling	0	0	Headset Detection Flag	0	0	0	0
R/W-0h	R/W-0h	R-0h	R-0h	R-0h	R-0h	R-0h	R-0h

Table 23. Register 14 Field Descriptions

Bit	Field	Type	Reset	Description
7	Driver Capacitive Coupling	R/W	0h	Driver capacitive coupling. 0: Programs high-power outputs for capacitor-free driver configuration 1: Programs high-power outputs for ac-coupled driver configuration
6	Reserved	R/W	0h	Reserved. Always write zero to this bit.
5	Reserved	R	0h	Reserved. Always write zero to this bit.
4	Headset Detection Flag	R	0h	Headset detection flag. 0: A headset is not detected 1: A headset is detected
3:0	Reserved	R	0h	Reserved. Always write zeros to these bits

7.6.2.16 Register 15: ADC PGA Gain Control Register (address = Fh) [reset = 1000 0000], Page 0
Figure 46. Register 15

7	6	5	4	3	2	1	0
ADC PGA Mute	ADC PGA Gain Setting						
R/W-1h	R/W-0h						

Table 24. Register 15 Field Descriptions

Bit	Field	Type	Reset	Description
7	ADC PGA Mute	R/W	1h	ADC PGA mute. 0: The ADC PGA is not muted 1: The ADC PGA is muted
6:0	ADC PGA Gain Setting	R/W	0h	ADC PGA gain setting. 000 0000: Gain = 0 dB 000 0001: Gain = 0.5 dB 000 0010: Gain = 1 dB ... 111 0110: Gain = 59 dB 111 0111: Gain = 59.5 dB 111 1000: Gain = 59.5 dB ... 111 1111: Gain = 59.5 dB

7.6.2.17 Register 16: Auxiliary PGA Gain Control Register (address = Fh) [reset = 1000 0000], Page 0
Figure 47. Register 16

7	6	5	4	3	2	1	0
PGA_AUX Mute		PGA_AUX Gain Setting					
R/W-1h		R/W-0h					

Table 25. Register 16 Field Descriptions

Bit	Field	Type	Reset	Description
7	PGA_AUX Mute	R/W	1h	PGA_AUX mute. 0: The auxiliary PGA is not muted 1: The auxiliary PGA is muted
6:0	PGA_AUX Gain Setting	R/W	0h	PGA_AUX gain setting. 000 0000: Gain = 0 dB 000 0001: Gain = 0.5 dB 000 0010: Gain = 1 dB ... 111 0110: Gain = 59 dB 111 0111: Gain = 59.5 dB 111 1000: Gain = 59.5 dB ... 111 1111: Gain = 59.5 dB

7.6.2.18 Register 17–18: Reserved (address = 11h–12h) [reset = 1111 1111], Page 0
Figure 48. Register 17

7	6	5	4	3	2	1	0
1	1	1	1	1	1	1	1
R/W-1h	R/W-1h	R/W-1h	R/W-1h	R/W-1h	R/W-1h	R/W-1h	R/W-1h

Table 26. Register 17 Field Descriptions

Bit	Field	Type	Reset	Description
7:0	Reserved	R/W	1h	Reserved. Always write ones to these bits.

7.6.2.19 Register 19: MIC1P/LINE1P to ADC Control Register (address = 13h) [reset = 0111 1000], Page 0
Figure 49. Register 19

7	6	5	4	3	2	1	0
MIC1P/LINE1P Single-Ended vs Fully Differential Control	MIC1P/LINE1P Input Level Control for ADC PGA Mix			ADC Channel Power Control		ADC PGA Soft-Stepping Control	
R/W-0h	R/W-1h			R/W-0h		R/W-0h	

Table 27. Register 19 Field Descriptions

Bit	Field	Type	Reset	Description
7	MIC1P/LINE1P Single-Ended vs Fully Differential Control	R/W	0h	MIC1P/LINE1P single-ended vs fully differential control. 0: MIC1P/LINE1P is configured in single-ended mode 1: MIC1P/LINE1P and MIC1M/LINE1M are configured in fully differential mode
6:3	MIC1P/LINE1P Input Level Control for ADC PGA Mix	R/W	1h	MIC1P/LINE1P input level control for ADC PGA mix. Setting the input level control to one of the following gains automatically connects LINE1L to the ADC PGA mix. 0000: Input level control gain = 0 dB 0001: Input level control gain = -1.5 dB 0010: Input level control gain = -3 dB 0011: Input level control gain = -4.5 dB 0100: Input level control gain = -6 dB 0101: Input level control gain = -7.5 dB 0110: Input level control gain = -9 dB 0111: Input level control gain = -10.5 dB 1000: Input level control gain = -12 dB 1001–1110: Reserved; do not write these sequences to these register bits 1111: LINE1L is not connected to the ADC PGA
2	ADC Channel Power Control	R/W	0h	ADC channel power control. 0: ADC channel is powered down 1: ADC channel is powered up
1:0	ADC PGA Soft-Stepping Control	R/W	0h	ADC PGA soft-stepping control. 00: ADC PGA soft-stepping at one time per sample period 01: ADC PGA soft-stepping at one time per two sample periods 10–11: ADC PGA soft-stepping is disabled

7.6.2.20 Register 20: Reserved (address = 14h) [reset = 0111 1000], Page 0
Figure 50. Register 20

7	6	5	4	3	2	1	0
0	1	1	1	1	0	0	0
R-0h	R-1h	R-1h	R-1h	R-1h	R-0h	R-0h	R-0h

Table 28. Register 20 Field Descriptions

Bit	Field	Type	Reset	Description
7:0	Reserved.	R	0111 1000h	Reserved. Always write 0111 1000 to these bits

7.6.2.21 Register 21: MIC2P/LINE2P to ADC Control Register (address = 15h) [reset = 0111 1000], Page 0

Figure 51. Register 21

7	6	5	4	3	2	1	0
MIC2P/LINE2P Single-Ended vs Fully Differential Control	MIC2P/LINE2P Input Level Control for ADC PGA Mix			0	0	0	
R/W-0h	R/W-1h			R-0h	R-0h	R-0h	

Table 29. Register 21 Field Descriptions

Bit	Field	Type	Reset	Description
7	MIC2P/LINE2P Single-Ended vs Fully Differential Control	R/W	0h	MIC2P/LINE2P single-ended vs fully differential control. 0: MIC2P/LINE2P is configured in single-ended mode 1: MIC2P/LINE2P and MIC2M/LINE2M are configured in fully differential mode
6:3	MIC2P/LINE2P Input Level Control for ADC PGA Mix	R/W	1h	MIC2P/LINE2P input level control for ADC PGA mix. Setting the input level control to one of the following gains automatically connects LINE1R to the ADC PGA mix. 0000: Input level control gain = 0 dB 0001: Input level control gain = -1.5 dB 0010: Input level control gain = -3 dB 0011: Input level control gain = -4.5 dB 0100: Input level control gain = -6 dB 0101: Input level control gain = -7.5 dB 0110: Input level control gain = -9 dB 0111: Input level control gain = -10.5 dB 1000: Input level control gain = -12 dB 1001–1110: Reserved; do not write these sequences to these register bits 1111: LINE1R is not connected to the ADC PGA
2:0	Reserved	R	0h	Reserved. Always write zeros to these bits.

7.6.2.22 Registers 22–24: Reserved (address = 16h–18h) [reset = 0111 1000], Page 0

Figure 52. Register 22

7	6	5	4	3	2	1	0
0	1	1	1	1	0	0	0
R/W-0h	R/W-1h	R/W-1h	R/W-1h	R/W-1h	R/W-0h	R/W-0h	R/W-0h

Table 30. Register 22 Field Descriptions

Bit	Field	Type	Reset	Description
7:0	Reserved	R/W	0111 1000h	Reserved. Always write 0111 1000 to these bits.

7.6.2.23 Register 25: MICBIAS Control Register (address = 25h) [reset = 0000 0110], Page 0
Figure 53. Register 25

7	6	5	4	3	2	1	0
MICBIAS Level Control	0	0	0	0	0	0	0
R/W-0h	R-0h	R-0h	R-0h	R-0h	R-Xh	R-Xh	R-Xh

Table 31. Register 25 Field Descriptions

Bit	Field	Type	Reset	Description
7:6	MICBIAS Level Control	R/W	0h	MICBIAS level control. 00: MICBIAS output is powered down 01: MICBIAS output is powered to 2 V 10: MICBIAS output is powered to 2.5 V 11: MICBIAS output is connected to AVDD
5:3	Reserved	R	0h	Reserved. Always write zeros to these bits
2:1	Reserved	R	1h	Reserved. Always write ones to these bits.
0	Reserved	R	0h	Reserved. Always write zero to this bit.

7.6.2.24 Register 26: AGC Control Register A (address = 1Ah) [reset = 0000 0000], Page 0
Figure 54. Register 26

7	6	5	4	3	2	1	0
AGC Enable	AGC Target Level		AGC Attack Time		AGC Decay Time		
R/W-0h	R/W-0h		R/W-0h		R/W-0h		

Table 32. Register 26 Field Descriptions

Bit	Field	Type	Reset	Description
7	AGC Enable	R/W	0h	AGC enable. 0: AGC is disabled 1: AGC is enabled
6:4	AGC Target Level	R/W	0h	AGC target level. 000: AGC target level = -5.5 dB 001: AGC target level = -8 dB 010: AGC target level = -10 dB 011: AGC target level = -12 dB 100: AGC target level = -14 dB 101: AGC target level = -17 dB 110: AGC target level = -20 dB 111: AGC target level = -24 dB
3:2	AGC Attack Time	R/W	0h	AGC attack time. These time constants ⁽¹⁾ are not accurate when double-rate audio mode is enabled. 00: AGC attack time = 8 ms 01: AGC attack time = 11 ms 10: AGC attack time = 16 ms 11: AGC attack time = 20 ms
1:0	AGC Decay Time	R/W	0h	AGC decay time. These time constants ⁽¹⁾ are not accurate when double-rate audio mode is enabled. 00: AGC decay time = 100 ms 01: AGC decay time = 200 ms 10: AGC decay time = 400 ms 11: AGC decay time = 500 ms

(1) Time constants are valid when DRA is not enabled. The values change if DRA is enabled.

7.6.2.25 Register 27: AGC Control Register B (address = 1Bh) [reset = 1111 1110], Page 0
Figure 55. Register 27

7	6	5	4	3	2	1	0
AGC Maximum Gain Allowed							0
R/W-1h							R/W-0h

Table 33. Register 27 Field Descriptions

Bit	Field	Type	Reset	Description
7:1	AGC Maximum Gain Allowed	R/W	1h	AGC maximum gain allowed. 0000 000: Maximum gain = 0 dB 0000 001: Maximum gain = 0.5 dB 0000 010: Maximum gain = 1 dB ... 1110 110: Maximum gain = 59 dB 1110 111–111 111: Maximum gain = 59.5 dB
0	Reserved	R/W	0h	Reserved. Always write zero to this bit.

7.6.2.26 Register 28: AGC Control Register C (address = 1Ch) [reset = 0000 0000], Page 0
Figure 56. Register 28

7	6	5	4	3	2	1	0
Noise Gate Hysteresis Level Control		AGC Noise Threshold Control				AGC Clip Stepping Control	
R/W-0h		R/W-0h				R/W-0h	

Table 34. Register 28 Field Descriptions

Bit	Field	Type	Reset	Description
7:6	Noise Gate Hysteresis Level Control	R/W	0h	Noise gate hysteresis level control. 00: Hysteresis = 1 dB 01: Hysteresis = 2 dB 10: Hysteresis = 3 dB 11: Hysteresis is disabled
5:1	AGC Noise Threshold Control	R/W	0h	AGC noise threshold control. 00000: AGC noise/silence detection disabled 00001: AGC noise threshold = –30 dB 00010: AGC noise threshold = –32 dB 00011: AGC noise threshold = –34 dB ... 11101: AGC noise threshold = –86 dB 11110: AGC noise threshold = –88 dB 11111: AGC noise threshold = –90 dB
0	AGC Clip Stepping Control	R/W	0h	AGC clip stepping control. 0: AGC clip stepping disabled 1: AGC clip stepping enabled

7.6.2.27 Register 29: Reserved (address = 1Dh) [reset = 0000 0000], Page 0
Figure 57. Register 29

7	6	5	4	3	2	1	0
0	0	0	0	0	0	0	0
R/W-0h	R/W-0h	R/W-0h	R/W-0h	R/W-0h	R/W-0h	R/W-0h	R/W-0h

Table 35. Register 29 Field Descriptions

Bit	Field	Type	Reset	Description
7:0	Reserved	R/W	0h	Reserved. Always write zeros to these bits.

7.6.2.28 Register 30: Reserved (address = 1Eh) [reset = 1111 1110], Page 0
Figure 58. Register 30

7	6	5	4	3	2	1	0
1	1	1	1	1	1	1	0
R/W-1h	R/W-1h	R/W-1h	R/W-1h	R/W-1h	R/W-1h	R/W-1h	R/W-0h

Table 36. Register 30 Field Descriptions

Bit	Field	Type	Reset	Description
7:0	Reserved	R/W	1111 1110h	Reserved. Always write 1111 1110 to these bits.

7.6.2.29 Register 31: Reserved (address = 1Fh) [reset = 0000 0000], Page 0
Figure 59. Register 31

7	6	5	4	3	2	1	0
0	0	0	0	0	0	0	0
R/W-0h	R/W-0h	R/W-0h	R/W-0h	R/W-0h	R/W-0h	R/W-0h	R/W-0h

Table 37. Register 31 Field Descriptions

Bit	Field	Type	Reset	Description
7:0	Reserved	R/W	0h	Reserved. Always write zeros to these bits.

7.6.2.30 Register 32: AGC Gain Register (address = 20h) [reset = 1000 0000], Page 0
Figure 60. Register 32

7	6	5	4	3	2	1	0
Channel Gain Applied by AGC Algorithm							
R-0h							

Table 38. Register 32 Field Descriptions

Bit	Field	Type	Reset	Description
7:0	Channel Gain Applied by AGC Algorithm	R	80h	Channel gain applied by AGC algorithm. 1110 1000: Gain = -12 dB 1110 1001: Gain = -11.5 dB 1110 1010: Gain = -11 dB ... 0000 0000: Gain = 0.0 dB 0000 0001: Gain = 0.5 dB ... 0111 0110: Gain = 59 dB 0111 0111: Gain = 59.5 dB

7.6.2.31 Register 33: Reserved (address = 21h) [reset = 0000 0000], Page 0
Figure 61. Register 33

7	6	5	4	3	2	1	0
0	0	0	0	0	0	0	0
R/W-0h	R/W-0h	R/W-0h	R/W-0h	R/W-0h	R/W-0h	R/W-0h	R/W-0h

Table 39. Register 33 Field Descriptions

Bit	Field	Type	Reset	Description
7:0	Reserved	R/W	0h	Reserved. Always write zeros to these bits.

7.6.2.32 Register 34: AGC Noise Gate Debounce Register (address = 22h) [reset = 0000 0000], Page 0
Figure 62. Register 34

7	6	5	4	3	2	1	0
AGC Noise Detection Debounce Control					AGC Signal Detection Debounce Control		
R/W-0h					R/W-0h		

Table 40. Register 34 Field Descriptions

Bit	Field	Type	Reset	Description
7:3	AGC Noise Detection Debounce Control	R/W	0h	AGC noise detection debounce control. These times ⁽¹⁾ are not accurate when double-rate audio mode is enabled. 0000 0: Debounce = 0 ms 0000 1: Debounce = 0.5 ms 0001 0: Debounce = 1 ms 0001 1: Debounce = 2 ms 0010 0: Debounce = 4 ms 0010 1: Debounce = 8 ms 0011 0: Debounce = 16 ms 0011 1: Debounce = 32 ms 0100 0: Debounce = 64 × 1 = 64 ms 0100 1: Debounce = 64 × 2 = 128 ms 0101 0: Debounce = 64 × 3 = 192 ms ... 1111 0: Debounce = 64 × 23 = 1,472 ms 1111 1: Debounce = 64 × 24 = 1,536 ms
2:0	AGC Signal Detection Debounce Control	R/W	0h	AGC signal detection debounce control. These times ⁽¹⁾ are not accurate when double-rate audio mode is enabled. 000: Debounce = 0 ms 001: Debounce = 0.5 ms 010: Debounce = 1 ms 011: Debounce = 2 ms 100: Debounce = 4 ms 101: Debounce = 8 ms 110: Debounce = 16 ms 111: Debounce = 32 ms

(1) Time constants are valid when DRA is not enabled. The values change when DRA is enabled.

7.6.2.33 Register 35: Reserved (address = 23h) [reset = 0000 0000], Page 0
Figure 63. Register 35

7	6	5	4	3	2	1	0
0	0	0	0	0	0	0	0
R/W-0h	R/W-0h	R/W-0h	R/W-0h	R/W-0h	R/W-0h	R/W-0h	R/W-0h

Table 41. Register 35 Field Descriptions

Bit	Field	Type	Reset	Description
7:0	Reserved	R/W	0h	Reserved. Always write zeros to these bits.

7.6.2.34 Register 36: ADC Flag Register (address = 24h) [reset = 0000 0000], Page 0
Figure 64. Register 36

7	6	5	4	3	2	1	0
ADC PGA Status	ADC Power Status	AGC Signal Detection Status	AGC Saturation Flag	0	0	0	0
R-0h	R-0h	R-0h	R-0h	R-0h	R-0h	R-0h	R-0h

Table 42. Register 36 Field Descriptions

Bit	Field	Type	Reset	Description
7	ADC PGA Status	R	0h	ADC PGA status. 0: Applied gain and programmed gain are not the same 1: Applied gain = programmed gain
6	ADC Power Status	R	0h	ADC power status. 0: ADC is in a power-down state 1: ADC is in a power-up state
5	AGC Signal Detection Status	R	0h	AGC signal detection status. 0: Signal power is greater than or equal to noise threshold 1: Signal power is less than noise threshold
4	AGC Saturation Flag	R	0h	AGC saturation flag. 0: AGC is not saturated 1: AGC gain applied = maximum allowed gain for AGC
3:0	Reserved	R	0h	Reserved. Always write zeros to these bits.

7.6.2.35 Register 37: DAC Power and Output Driver Control Register (address = 25h) [reset = 0000 0000], Page 0
Figure 65. Register 37

7	6	5	4	3	2	1	0
DAC Power Control	0	0	0	0	0	0	0
R/W-0h	R/W-0h	R/W-0h	R/W-0h	R-0h	R-0h	R-0h	R-0h

Table 43. Register 37 Field Descriptions

Bit	Field	Type	Reset	Description
7	DAC Power Control	R/W	0h	DAC power control. 0: DAC is not powered up 1: DAC is powered up
6:4	Reserved	R/W	0h	Reserved. Always write zeros to these bits.
3:0	Reserved	R	0h	Reserved. Always write zeros to these bits.

7.6.2.36 Register 38: High-Power Output Driver Control Register (address = 26h) [reset = 0000 0000], Page 0
Figure 66. Register 38

7	6	5	4	3	2	1	0
0	0	HPCOM Output Driver Configuration Control		Short-Circuit Protection Control		Short-Circuit Protection Mode Control	
R-0h	R-0h	R/W-0h		R/W-0h		R/W-0h	

Table 44. Register 38 Field Descriptions

Bit	Field	Type	Reset	Description
7:6	Reserved	R	0h	Reserved. Always write zeros to these register bits.
5:3	HPCOM Output Driver Configuration Control	R/W	0h	HPCOM output driver configuration control. 000: HPCOM is configured as a differential of HPOUT 001: HPCOM is configured as a constant VCM output 010: HPCOM is configured as independent single-ended output 011-111: Reserved
2	Short-Circuit Protection Control	R/W	0h	Short-circuit protection control. 0: Short-circuit protection on all high-power output drivers is disabled 1: Short-circuit protection on all high-power output drivers is enabled
1	Short-Circuit Protection Mode Control	R/W	0h	Short-circuit protection mode control. 0: If short-circuit protection is enabled, the maximum current is limited to the load 1: If short-circuit protection is enabled, the output driver is automatically powered down when a short is detected
0	Reserved	R	0h	Reserved. Always write a zero to this bit.

7.6.2.37 Register 39: Reserved (address = 27h) [reset = 0000 0000], Page 0
Figure 67. Register 39

7	6	5	4	3	2	1	0
0	0	0	0	0	0	0	0
R-0h	R-0h	R-0h	R-0h	R-0h	R-0h	R-0h	R-0h

Table 45. Register 39 Field Descriptions

Bit	Field	Type	Reset	Description
7:0	Reserved	R	0h	Reserved. Always write zeros to these bits.

7.6.2.38 Register 40: High-Power Output Stage Control Register (address = 28h) [reset = 0000 0000], Page 0
Figure 68. Register 40

7	6	5	4	3	2	1	0
Output Common-Mode Voltage Control		0	0	0	0		Output Volume Control Soft-Stepping
R/W-0h		R/W-0h	R/W-0h	R/W-0h	R/W-0h		R/W-0h

Table 46. Register 40 Field Descriptions

Bit	Field	Type	Reset	Description
7:6	Output Common-Mode Voltage Control	R/W	0h	Output common-mode voltage control. 00: Output common-mode voltage = 1.35 V 01: Output common-mode voltage = 1.5 V 10: Output common-mode voltage = 1.65 V 11: Output common-mode voltage = 1.8 V
5:2	Reserved	R/W	0h	Reserved. Always write zeros to these bits.
1:0	Output Volume Control Soft-Stepping	R/W	0h	Output volume control soft-stepping. 00: Output soft-stepping = one step per sample period 01: Output soft-stepping = one step per two sample periods 10: Output soft-stepping disabled 11: Reserved; do not write this sequence to these bits

7.6.2.39 Register 41: DAC Output Switching Control Register (address = 29h) [reset = 0000 0000], Page 0
Figure 69. Register 41

7	6	5	4	3	2	1	0
DAC Output Switching Control		0	0	0	0	0	0
R/W-0h		R/W-0h	R/W-0h	R/W-0h	R/W-0h	R/W-0h	R/W-0h

Table 47. Register 41 Field Descriptions

Bit	Field	Type	Reset	Description
7:6	DAC Output Switching Control	R/W	0h	DAC output switching control. 00: DAC output selects DAC_1 path 01: DAC output selects DAC_3 path to left line output driver 10, 11: Reserved. Do not write this sequence to these register bits
5:0	Reserved	R/W	0h	Reserved. Always write zeros to these bits.

7.6.2.40 Register 42: Output Driver Pop Reduction Register (address = 2Ah) [reset = 0000 0000], Page 0

Figure 70. Register 42

7	6	5	4	3	2	1	0
Output Driver Power-On Delay Control			Driver Ramp-Up Step Timing Control		Weak Output Common-Mode Voltage Control		0
R/W-0h			R/W-0h		R/W-0h		R/W-0h

Table 48. Register 42 Field Descriptions

Bit	Field	Type	Reset	Description
7:4	Output Driver Power-On Delay Control	R/W	0h	Output driver power-on delay control. 0000: Driver power-on time = 0 μs 0001: Driver power-on time = 10 μs 0010: Driver power-on time = 100 μs 0011: Driver power-on time = 1 ms 0100: Driver power-on time = 10 ms 0101: Driver power-on time = 50 ms 0110: Driver power-on time = 100 ms 0111: Driver power-on time = 200 ms 1000: Driver power-on time = 400 ms 1001: Driver power-on time = 800 ms 1010: Driver power-on time = 2 s 1011: Driver power-on time = 4 s 1100–1111: Reserved; do not write these sequences to these register bits
3:2	Driver Ramp-Up Step Timing Control	R/W	0h	Driver ramp-up step timing control. 00: Driver ramp-up step time = 0 ms 01: Driver ramp-up step time = 1 ms 10: Driver ramp-up step time = 2 ms 11: Driver ramp-up step time = 4 ms
1	Weak Output Common-Mode Voltage Control	R/W	0h	Weak output common-mode voltage control. 0: Weakly driven output common-mode voltage is generated from resistor divider off the AVDD supply 1: Weakly driven output common-mode voltage is generated from band-gap reference
0	Reserved	R/W	0h	Reserved. Always write zero to this bit.

7.6.2.41 Register 43: DAC Digital Volume Control Register (address = 2Bh) [reset = 1000 0000], Page 0

Figure 71. Register 43

7	6	5	4	3	2	1	0
DAC Digital Mute		DAC Digital Volume Control Setting					
R/W-1h		R/W-0h					

Table 49. Register 43 Field Descriptions

Bit	Field	Type	Reset	Description
7	DAC Digital Mute	R/W	1h	DAC digital mute. 0: The DAC channel is not muted 1: The DAC channel is muted
6:0	DAC Digital Volume Control Setting	R/W	0h	DAC digital volume control setting. 000 0000: Gain = 0 dB 000 0001: Gain = –0.5 dB 000 0010: Gain = –1 dB ... 111 1101: Gain = –62.5 dB 111 1110: Gain = –63 dB 111 1111: Gain = –63.5 dB

7.6.2.42 Register 44: Reserved (address = 2Ch) [reset = 1000 0000], Page 0
Figure 72. Register 44

7	6	5	4	3	2	1	0
1	0	0	0	0	0	0	0
R/W-1h	R/W-0h	R/W-0h	R/W-0h	R/W-0h	R/W-0h	R/W-0h	R/W-0h

Table 50. Register 44 Field Descriptions

Bit	Field	Type	Reset	Description
7:0	Reserved	R/W	1000 0000h	Reserved. Always write 1000 0000 to these bits.

7.6.2.43 Registers 45–50: Reserved (address = 2Dh–32h) [reset = 0000 0000], Page 0
Figure 73. Register 45

7	6	5	4	3	2	1	0
0	0	0	0	0	0	0	0
R/W-0h	R/W-0h	R/W-0h	R/W-0h	R/W-0h	R/W-0h	R/W-0h	R/W-0h

Table 51. Register 45 Field Descriptions

Bit	Field	Type	Reset	Description
7:0	Reserved	R/W	0h	Reserved. Always write zeros to these bits.

7.6.2.44 Register 51: Reserved (address = 33h) [reset = 0000 0100], Page 0
Figure 74. Register 51

7	6	5	4	3	2	1	0
0	0	0	0	0	1	1	0
R/W-0h	R/W-0h	R/W-0h	R/W-0h	R/W-0h	R/W-1h	R/W-1h	R/W-0h

Table 52. Register 51 Field Descriptions

Bit	Field	Type	Reset	Description
7:0	Reserved	R/W	0000 0100h	Reserved. Always write 0000 0100 to these bits.

7.6.2.45 Registers 52–57: Reserved (address = 34h–39h) [reset = 0000 0000], Page 0
Figure 75. Register 52

7	6	5	4	3	2	1	0
0	0	0	0	0	0	0	0
R/W-0h	R/W-0h	R/W-0h	R/W-0h	R/W-0h	R/W-0h	R/W-0h	R/W-0h

Table 53. Register 52 Field Descriptions

Bit	Field	Type	Reset	Description
7:0	Reserved	R/W	0h	Reserved. Always write zeros to these bits.

7.6.2.46 Register 58: Reserved (address = 3Ah) [reset = 0000 0100], Page 0

Figure 76. Register 58

7	6	5	4	3	2	1	0
0	0	0	0	0	1	1	0
R/W-0h	R/W-0h	R/W-0h	R/W-0h	R/W-0h	R/W-1h	R/W-1h	R/W-0h

Table 54. Register 58 Field Descriptions

Bit	Field	Type	Reset	Description
7:0	Reserved	R/W	0000 0100h	Reserved. Always write 0000 0100 to these bits.

7.6.2.47 Register 59: Reserved (address = 3Bh) [reset = 0000 0000], Page 0

Figure 77. Register 59

7	6	5	4	3	2	1	0
0	0	0	0	0	0	0	0
R/W-0h	R/W-0h	R/W-0h	R/W-0h	R/W-0h	R/W-0h	R/W-0h	R/W-0h

Table 55. Register 59 Field Descriptions

Bit	Field	Type	Reset	Description
7:0	Reserved	R/W	0h	Reserved. Always write zeros to these bits.

7.6.2.48 Register 60: PGA to HPOUT Volume Control Register (address = 3Ch) [reset = 0000 0000], Page 0

Figure 78. Register 60

7	6	5	4	3	2	1	0
PGA Output Routing Control		PGA to HPOUT Analog Volume Control					
R/W-0h		R/W-0h					

Table 56. Register 60 Field Descriptions

Bit	Field	Type	Reset	Description
7	PGA Output Routing Control	R/W	0h	PGA output routing control. 0: PGA is not routed to HPOUT 1: PGA is routed to HPOUT
6:0	PGA to HPOUT Analog Volume Control	R/W	0h	PGA to HPOUT analog volume control. For 7-bit register settings versus analog gain values, see Table 6 .

7.6.2.49 Register 61: DAC_1 to HPOUT Volume Control Register (address = 3Dh) [reset = 0000 0000], Page 0
Figure 79. Register 61

7	6	5	4	3	2	1	0
DAC_1 Output Routing Control		DAC_1 to HPOUT Analog Volume Control					
R/W-0h		R/W-0h					

Table 57. Register 61 Field Descriptions

Bit	Field	Type	Reset	Description
7	DAC_1 Output Routing Control	R/W	0h	DAC_1 output routing control. 0: DAC_1 is not routed to HPOUT 1: DAC_1 is routed to HPOUT
6:0	DAC_1 to HPOUT Analog Volume Control	R/W	0h	DAC_1 to HPOUT analog volume control. For 7-bit register settings versus analog gain values, see Table 6 .

7.6.2.50 Register 62: Reserved Register (address = 3Eh) [reset = 0000 0000], Page 0
Figure 80. Register 62

7	6	5	4	3	2	1	0
0	0	0	0	0	0	0	0
R/W-0h	R/W-0h	R/W-0h	R/W-0h	R/W-0h	R/W-0h	R/W-0h	R/W-0h

Table 58. Register 62 Field Descriptions

Bit	Field	Type	Reset	Description
7:0	Reserved	R/W	0h	Reserved. Always write zeros to these bits.

7.6.2.51 Register 63: PGA_AUX to HPOUT Volume Control Register (address = 3Fh) [reset = 0000 0000], Page 0
Figure 81. Register 63

7	6	5	4	3	2	1	0
PGA_AUX Output Routing Control		PGA_AUX to HPOUT Analog Volume Control					
R/W-0h		R/W-0h					

Table 59. Register 63 Field Descriptions

Bit	Field	Type	Reset	Description
7	PGA_AUX Output Routing Control	R/W	0h	PGA_AUX output routing control. 0: PGA_AUX is not routed to HPOUT 1: PGA_AUX is routed to HPOUT
6:0	PGA_AUX to HPOUT Analog Volume Control	R/W	0h	PGA_AUX to HPOUT analog volume control. For 7-bit register settings versus analog gain values, see Table 6 .

7.6.2.52 Register 64: Reserved (address = 40h) [reset = 0000 0000], Page 0
Figure 82. Register 64

7	6	5	4	3	2	1	0
0	0	0	0	0	0	0	0
R/W-0h	R/W-0h	R/W-0h	R/W-0h	R/W-0h	R/W-0h	R/W-0h	R/W-0h

Table 60. Register 64 Field Descriptions

Bit	Field	Type	Reset	Description
7:0	Reserved	RW	0h	Reserved. Always write zeros to these bits.

7.6.2.53 Register 65: HPOUT Output Level Control Register (address = 41h) [reset = 0000 0100], Page 0
Figure 83. Register 65

7	6	5	4	3	2	1	0
HPOUT Output Level Control			HPOUT Mute		HPOUT Power-Down Drive Control	HPOUT Volume Control Status	HPOUT Power Control
R/W-0h			R/W-0h		R/W-1h	R-0h	R/W-0h

Table 61. Register 65 Field Descriptions

Bit	Field	Type	Reset	Description
7:4	HPOUT Output Level Control	R/W	0h	HPOUT output level control. 0000: Output level control = 0 dB 0001: Output level control = 1 dB 0010: Output level control = 2 dB ... 1000: Output level control = 8 dB 1001: Output level control = 9 dB 1010–1111: Reserved; do not write these sequences to these register bits
3	HPOUT Mute	R/W	0h	HPOUT mute. 0: HPOUT is muted 1: HPOUT is not muted.
2	HPOUT Power-Down Drive Control	R/W	1h	HPOUT power-down drive control. 0: HPOUT is weakly driven to a common mode when powered down 1: HPOUT is high-impedance when powered down
1	HPOUT Volume Control Status	R	0h	HPOUT volume control status. 0: All programmed gains to HPOUT are applied 1: Not all programmed gains to HPOUT are applied yet
0	HPOUT Power Control	R/W	0h	HPOUT power control. 0: HPOUT is not fully powered up 1: HPOUT is fully powered up

7.6.2.54 Register 66: Reserved (address = 42h) [reset = 0000 0000], Page 0
Figure 84. Register 66

7	6	5	4	3	2	1	0
0	0	0	0	0	0	0	0
R/W-0h	R/W-0h	R/W-0h	R/W-0h	R/W-0h	R/W-0h	R/W-0h	R/W-0h

Table 62. Register 66 Field Descriptions

Bit	Field	Type	Reset	Description
7:0	Reserved	R/W	0h	Reserved. Always write zeros to these bits.

7.6.2.55 Register 67: PGA to HPCOM Volume Control Register (address = 43h) [reset = 0000 0000], Page 0
Figure 85. Register 67

7	6	5	4	3	2	1	0
PGA Output Routing Control		PGA to HPCOM Analog Volume Control					
R/W-0h		R/W-0h					

Table 63. Register 67 Field Descriptions

Bit	Field	Type	Reset	Description
7	PGA Output Routing Control	R/W	0h	PGA output routing control. 0: PGA is not routed to HPCOM 1: PGA is routed to HPCOM
6:0	PGA to HPCOM Analog Volume Control	R/W	0h	PGA to HPCOM analog volume control. For 7-bit register settings versus analog gain values, see Table 6 .

7.6.2.56 Register 68: DAC_1 to HPCOM Volume Control Register (address = 44h) [reset = 0000 0000], Page 0
Figure 86. Register 68

7	6	5	4	3	2	1	0
DAC_1 Output Routing Control		DAC_1 to HPCOM Analog Volume Control					
R/W-0h		R/W-0h					

Table 64. Register 68 Field Descriptions

Bit	Field	Type	Reset	Description
7	DAC_1 Output Routing Control	R/W	0h	DAC_1 output routing control. 0: DAC_1 is not routed to HPCOM 1: DAC_1 is routed to HPCOM
6:0	DAC_1 to HPCOM Analog Volume Control	R/W	0h	DAC_1 to HPCOM analog volume control. For 7-bit register settings versus analog gain values, see Table 6 .

7.6.2.57 Register 69: Reserved (address = 45h) [reset = 0000 0000], Page 0
Figure 87. Register 69

7	6	5	4	3	2	1	0
0	0	0	0	0	0	0	0
R/W-0h	R/W-0h	R/W-0h	R/W-0h	R/W-0h	R/W-0h	R/W-0h	R/W-0h

Table 65. Register 69 Field Descriptions

Bit	Field	Type	Reset	Description
7:0	Reserved	R/W	0h	Reserved. Always write zeros to these bits.

7.6.2.58 Register 70: PGA_AUX to HPCOM Volume Control Register (address = 46h) [reset = 0000 0000], Page 0
Figure 88. Register 70

7	6	5	4	3	2	1	0
PGA_AUX Output Routing Control	PGA_AUX to HPCOM Analog Volume Control						
R/W-0h	R/W-0h						

Table 66. Register 70 Field Descriptions

Bit	Field	Type	Reset	Description
7	PGA_AUX Output Routing Control	R/W	0h	PGA_AUX output routing control. 0: PGA_AUX is not routed to HPCOM 1: PGA_AUX is routed to HPCOM
6:0	PGA_AUX to HPCOM Analog Volume Control	R/W	0h	PGA_AUX to HPCOM analog volume control. For 7-bit register settings versus analog gain values, see Table 6 .

7.6.2.59 Register 71: Reserved (address = 47h) [reset = 0000 0000], Page 0
Figure 89. Register 71

7	6	5	4	3	2	1	0
0	0	0	0	0	0	0	0
R/W-0h	R/W-0h	R/W-0h	R/W-0h	R/W-0h	R/W-0h	R/W-0h	R/W-0h

Table 67. Register 71 Field Descriptions

Bit	Field	Type	Reset	Description
7:0	Reserved	R/W	0h	Reserved. Always write zeros to these bits.

7.6.2.60 Register 72: HPCOM Output Level Control Register (address = 48h) [reset = 0000 0100], Page 0
Figure 90. Register 72

7	6	5	4	3	2	1	0
HPCOM Output Level Control			HPCOM Mute		HPCOM Power-Down Drive Control	HPCOM Volume Control Status	HPCOM Power Control
R/W-0h			R/W-0h		R/W-1h	R/0h	R/W-0h

Table 68. Register 72 Field Descriptions

Bit	Field	Type	Reset	Description
7:4	HPCOM Output Level Control	R/W	0h	HPCOM output level control. 0000: Output level control = 0 dB 0001: Output level control = 1 dB 0010: Output level control = 2 dB ... 1000: Output level control = 8 dB 1001: Output level control = 9 dB 1010–1111: Reserved; do not write these sequences to these register bits
3	HPCOM Mute	R/W	0h	HPCOM mute. 0: HPCOM is muted 1: HPCOM is not muted
2	HPCOM Power-Down Drive Control	R/W	1h	HPCOM power-down drive control. 0: HPCOM is weakly driven to a common mode when powered down 1: HPCOM is high-impedance when powered down
1	HPCOM Volume Control Status	R	0h	HPCOM volume control status. 0: All programmed gains to HPCOM are applied 1: Not all programmed gains to HPCOM are applied yet
0	HPCOM Power Control	R/W	0h	HPCOM power control. 0: HPCOM is not fully powered up 1: HPCOM is fully powered up

7.6.2.61 Registers 73–80: Reserved (address = 49h–50h) [reset = 0000 0000], Page 0
Figure 91. Registers 73–80

7	6	5	4	3	2	1	0
0	0	0	0	0	0	0	0
R/W-0h	R/W-0h	R/W-0h	R/W-0h	R/W-0h	R/W-0h	R/W-0h	R/W-0h

Table 69. Registers 73–80 Field Descriptions

Bit	Field	Type	Reset	Description
7:0	Reserved	R/W	0h	Reserved. Always write zeros to these bits.

7.6.2.62 Register 81: PGA to LEFT_LOP/M Volume Control Register (address = 51h) [reset = 0000 0000], Page 0
Figure 92. Register 81

7	6	5	4	3	2	1	0
PGA Output Routing Control		PGA to LEFT_LOP/M Analog Volume Control					
R/W-0h		R/W-0h					

Table 70. Register 81 Field Descriptions

Bit	Field	Type	Reset	Description
7	PGA Output Routing Control	R/W	0h	PGA output routing control. 0: PGA is not routed to LEFT_LOP, LEFT_LOM 1: PGA is routed to LEFT_LOP, LEFT_LOM
6:0	PGA to LEFT_LOP/M Analog Volume Control	R/W	0h	PGA to LEFT_LOP, LEFT_LOM analog volume control. For 7-bit register settings versus analog gain values, see Table 6 .

7.6.2.63 Register 82: DAC_1 to LEFT_LOP/M Volume Control Register (address = 52h) [reset = 0000 0000], Page 0
Figure 93. Register 82

7	6	5	4	3	2	1	0
DAC_1 Output Routing Control		DAC_1 to LEFT_LOP/M Analog Volume Control					
R/W-0h		R/W-0h					

Table 71. Register 82 Field Descriptions

Bit	Field	Type	Reset	Description
7	DAC_1 Output Routing Control	R/W	0h	DAC_1 output routing control. 0: DAC_1 is not routed to LEFT_LOP, LEFT_LOM 1: DAC_1 is routed to LEFT_LOP, LEFT_LOM
6:0	DAC_1 to LEFT_LOP/M Analog Volume Control	R/W	0h	DAC_1 to LEFT_LOP, LEFT_LOM analog volume control. For 7-bit register settings versus analog gain values, see Table 6 .

7.6.2.64 Register 83: Reserved (address = 53h) [reset = 0000 0000], Page 0
Figure 94. Register 83

7	6	5	4	3	2	1	0
0	0	0	0	0	0	0	0
R/W-0h	R/W-0h	R/W-0h	R/W-0h	R/W-0h	R/W-0h	R/W-0h	R/W-0h

Table 72. Register 83 Field Descriptions

Bit	Field	Type	Reset	Description
7:0	Reserved	R/W	0h	Reserved. Always write zeros to these bits.

7.6.2.65 Register 84: PGA_AUX to LEFT_LOP/M Volume Control Register (address = 54h) [reset = 0000 0000], Page 0
Figure 95. Register 84

7	6	5	4	3	2	1	0
PGA_AUX Output Routing Control		PGA_AUX to LEFT_LOP/M Analog Volume Control					
R/W-0h		R/W-0h					

Table 73. Register 84 Field Descriptions

Bit	Field	Type	Reset	Description
7	PGA_AUX Output Routing Control	R/W	0h	PGA_AUX output routing control. 0: PGA_AUX is not routed to LEFT_LOP, LEFT_LOM 1: PGA_AUX is routed to LEFT_LOP, LEFT_LOM
6:0	PGA_AUX to LEFT_LOP/M Analog Volume Control	R/W	0h	PGA_AUX to LEFT_LOP, LEFT_LOM analog volume control. For 7-bit register settings versus analog gain values, see Table 6 .

7.6.2.66 Register 85: Reserved (address = 55h) [reset = 0000 0000], Page 0
Figure 96. Register 85

7	6	5	4	3	2	1	0
0	0	0	0	0	0	0	0
R/W-0h	R/W-0h	R/W-0h	R/W-0h	R/W-0h	R/W-0h	R/W-0h	R/W-0h

Table 74. Register 85 Field Descriptions

Bit	Field	Type	Reset	Description
7:0	Reserved	R/W	0h	Reserved. Always write zeros to these bits.

7.6.2.67 Register 86: LEFT_LOP/M Output Level Control Register (address = 56h) [reset = 0000 0000], Page 0

Figure 97. Register 86

7	6	5	4	3	2	1	0
LEFT_LOP/M Output Level Control			LEFT_LOP/M Mute		0	LEFT_LOP/M Volume Control Status	LEFT_LOP/M Power Status
R/W-0h			R/W-0h		R-0h	R-0h	R-0h

Table 75. Register 86 Field Descriptions

Bit	Field	Type	Reset	Description
7:4	LEFT_LOP/M Output Level Control	R/W	0h	LEFT_LOP, LEFT_LOM output level control. 0000: Output level control = 0 dB 0001: Output level control = 1 dB 0010: Output level control = 2 dB ... 1000: Output level control = 8 dB 1001: Output level control = 9 dB 1010–1111: Reserved; do not write these sequences to these register bits
3	LEFT_LOP/M Mute	R/W	0h	LEFT_LOP, LEFT_LOM mute. 0: LEFT_LOP, LEFT_LOM are muted 1: LEFT_LOP, LEFT_LOM are not muted
2	Reserved	R	0h	Reserved. Always write zero to this bit.
1	LEFT_LOP/M Volume Control Status	R	0h	LEFT_LOP, LEFT_LOM volume control status. 0: All programmed gains to LEFT_LOP, LEFT_LOM are applied 1: Not all programmed gains to LEFT_LOP, LEFT_LOM are applied yet
0	LEFT_LOP/M Power Status	R	0h	LEFT_LOP, LEFT_LOM power status. 0: LEFT_LOP, LEFT_LOM is not fully powered up 1: LEFT_LOP, LEFT_LOM is fully powered up

7.6.2.68 Register 87: Reserved (address = 57h) [reset = 0000 0000], Page 0

Figure 98. Register 87

7	6	5	4	3	2	1	0
0	0	0	0	0	0	0	0
R/W-0h	R/W-0h	R/W-0h	R/W-0h	R/W-0h	R/W-0h	R/W-0h	R/W-0h

Table 76. Register 87 Field Descriptions

Bit	Field	Type	Reset	Description
7:0	Reserved	R/W	0h	Reserved. Always write zeros to these bits.

7.6.2.69 Register 88: PGA to RIGHT_LOP/M Volume Control (address = 58h) [reset = 0000 0000], Page 0
Figure 99. Register 88

7	6	5	4	3	2	1	0
PGA Output Routing Control		PGA to RIGHT_LOP/M Analog Volume Control					
R/W-0h		R/W-0h					

Table 77. Register 88 Field Descriptions

Bit	Field	Type	Reset	Description
7	PGA Output Routing Control	R/W	0h	PGA output routing control. 0: PGA is not routed to RIGHT_LOP, RIGHT_LOM 1: PGA is routed to RIGHT_LOP, RIGHT_LOM
6:0	PGA to RIGHT_LOP/M Analog Volume Control	R/W	0h	PGA to RIGHT_LOP, RIGHT_LOM analog volume control. For 7-bit register settings versus analog gain values, see Table 6 .

7.6.2.70 Register 89: DAC_1 to RIGHT_LOP/M Volume Control (address = 59h) [reset = 0000 0000], Page 0
Figure 100. Register 89

7	6	5	4	3	2	1	0
DAC_1 Output Routing Control		DAC_1 to RIGHT_LOP/M Analog Volume Control					
R/W-0h		R/W-0h					

Table 78. Register 89 Field Descriptions

Bit	Field	Type	Reset	Description
7	DAC_1 Output Routing Control	R/W	0h	DAC_1 output routing control. 0: DAC_1 is not routed to RIGHT_LOP, RIGHT_LOM 1: DAC_1 is routed to RIGHT_LOP, RIGHT_LOM
6:0	DAC_1 to RIGHT_LOP/M Analog Volume Control	R/W	0h	DAC_1 to RIGHT_LOP, RIGHT_LOM analog volume control. For 7-bit register settings versus analog gain values, see Table 6 .

7.6.2.71 Register 90: Reserved (address = 5A) [reset = 0000 0000], Page 0
Figure 101. Register 90

7	6	5	4	3	2	1	0
0	0	0	0	0	0	0	0
R/W-0h	R/W-0h	R/W-0h	R/W-0h	R/W-0h	R/W-0h	R/W-0h	R/W-0h

Table 79. Register 90 Field Descriptions

Bit	Field	Type	Reset	Description
7:0	Reserved	R/W	0h	Reserved. Always write zeros to these bits.

7.6.2.72 Register 91: PGA_AUX to RIGHT_LOP/M Volume Control (address = 5Bh) [reset = 0000 0000], Page 0
Figure 102. Register 91

7	6	5	4	3	2	1	0
PGA_AUX Output Routing Control	PGA_AUX to RIGHT_LOP/M Analog Volume Control						
R/W-0h	R/W-0h						

Table 80. Register 91 Field Descriptions

Bit	Field	Type	Reset	Description
7	PGA_AUX Output Routing Control	R/W	0h	PGA_AUX output routing control. 0: PGA_AUX is not routed to RIGHT_LOP, RIGHT_LOM 1: PGA_AUX is routed to RIGHT_LOP, RIGHT_LOM
6:0	PGA_AUX to RIGHT_LOP/M Analog Volume Control	R/W	0h	PGA_AUX to RIGHT_LOP, RIGHT_LOM analog volume control. For 7-bit register settings versus analog gain values, see Table 6 .

7.6.2.73 Register 92: Reserved (address = 5Ch) [reset = 0000 0000], Page 0
Figure 103. Register 92

7	6	5	4	3	2	1	0
0	0	0	0	0	0	0	0
R/W-0h	R/W-0h	R/W-0h	R/W-0h	R/W-0h	R/W-0h	R/W-0h	R/W-0h

Table 81. Register 92 Field Descriptions

Bit	Field	Type	Reset	Description
7:0	Reserved	R/W	0h	Reserved. Always write zeros to these bits.

7.6.2.74 Register 93: RIGHT_LOP/M Output Level Control (address = 5Dh) [reset = 0000 0000], Page 0
Figure 104. Register 93

7	6	5	4	3	2	1	0
RIGHT_LOP/M Output Level Control			RIGHT_LOP/M Mute		0	RIGHT_LOP/M Volume Control Status	RIGHT_LOP/M Power Status
R/W-0h			R/W-0h		R-0h	R-0h	R-0h

Table 82. Register 93 Field Descriptions

Bit	Field	Type	Reset	Description
7:4	RIGHT_LOP/M Output Level Control	R/W	0h	RIGHT_LOP, RIGHT_LOM output level control. 0000: Output level control = 0 dB 0001: Output level control = 1 dB 0010: Output level control = 2 dB ... 1000: Output level control = 8 dB 1001: Output level control = 9 dB 1010–1111: Reserved; do not write these sequences to these bits
3	RIGHT_LOP/M Mute	R/W	0h	RIGHT_LOP, RIGHT_LOM mute. 0: RIGHT_LOP, RIGHT_LOM are muted 1: RIGHT_LOP, RIGHT_LOM are not muted
2	Reserved	R	0h	Reserved. Always write zero to this bit.
1	RIGHT_LOP/M Volume Control Status	R	0h	RIGHT_LOP, RIGHT_LOM volume control status. 0: All programmed gains to RIGHT_LOP, RIGHT_LOM are applied 1: Not all programmed gains to RIGHT_LOP, RIGHT_LOM are applied yet
0	RIGHT_LOP/M Power Status	R	0h	RIGHT_LOP, RIGHT_LOM power status/ 0: RIGHT_LOP, RIGHT_LOM are not fully powered up 1: RIGHT_LOP, RIGHT_LOM are fully powered up

7.6.2.75 Register 94: Module Power Status Register (address = 5Eh) [reset = 0000 0000], Page 0
Figure 105. Register 94

7	6	5	4	3	2	1	0
DAC Power Status	0	0	LEFT_LOP/M Power Status	RIGHT_LOP/M Power Status	0	HPOUT Driver Power Status	0
R-0h	R-0h	R-0h	R-0h	R-0h	R-0h	R-0h	R-0h

Table 83. Register 94 Field Descriptions

Bit	Field	Type	Reset	Description
7	DAC Power Status	R	0h	DAC power status. 0: DAC is not fully powered up 1: DAC is fully powered up
6:5	Reserved	R	0h	Reserved. Always write zeros to these bits.
4	LEFT_LOP/M Power Status	R	0h	LEFT_LOP, LEFT_LOM power status. 0: LEFT_LOP, LEFT_LOM output driver is powered down 1: LEFT_LOP, LEFT_LOM output driver is powered up
3	RIGHT_LOP/M Power Status	R	0h	RIGHT_LOP, RIGHT_LOM power status. 0: RIGHT_LOP, RIGHT_LOM is not fully powered up 1: RIGHT_LOP, RIGHT_LOM is fully powered up
2	Reserved	R	0h	Reserved. Always write zero to this bit.
1	HPOUT Driver Power Status	R	0h	HPOUT driver power status. 0: HPOUT driver is not fully powered up 1: HPOUT driver is fully powered up
0	Reserved	R	0h	Reserved. Always write zero to this bit.

7.6.2.76 Register 95: Output Driver Short-Circuit Detection Status Register (address = 5Fh) [reset = 0000 0000], Page 0
Figure 106. Register 95

7	6	5	4	3	2	1	0
0	HPOUT Short-Circuit Detection Status	0	HPCOM Short-Circuit Detection Status	0	HPCOM Power Status	0	0
R-0h	R-0h	R-0h	R-0h	R-0h	R-0h	R-0h	R-0h

Table 84. Register 95 Field Descriptions

Bit	Field	Type	Reset	Description
7	Reserved	R	0h	Reserved. Always write zero to this bit.
6	HPOUT Short-Circuit Detection Status	R	0h	HPOUT short-circuit detection status. 0: No short circuit detected at HPOUT 1: Short circuit detected at HPOUT
5	Reserved	R	0h	Reserved. Always write zero to this bit.
4	HPCOM Short-Circuit Detection Status	R	0h	HPCOM short-circuit detection status. 0: No short circuit detected at HPCOM 1: Short circuit detected at HPCOM
3	Reserved	R	0h	Reserved. Always write zero to this bit.
2	HPCOM Power Status	R	0h	HPCOM power status. 0: HPCOM is not fully powered up 1: HPCOM is fully powered up
1:0	Reserved	R	0h	Reserved. Always write zeros to these bits.

7.6.2.77 Register 96: Sticky Interrupt Flags Register (address = 60h) [reset = 0000 0000], Page 0
Figure 107. Register 96

7	6	5	4	3	2	1	0
0	HPOUT Short-Circuit Detection Status	0	HPCOM Short-Circuit Detection Status	0	Headset Detection Status	ADC AGC Noise Gate Status	0
R-0h	R-0h	R-0h	R-0h	R-0h	R-0h	R-0h	R-0h

Table 85. Register 96 Field Descriptions

Bit	Field	Type	Reset	Description
7	Reserved	R	0h	Reserved. Always write zero to this bit.
6	HPOUT Short-Circuit Detection Status	R	0h	HPOUT short-circuit detection status. 0: No short circuit detected at HPOUT driver 1: Short circuit detected at HPOUT driver
5	Reserved	R	0h	Reserved. Always write zero to this bit.
4	HPCOM Short-Circuit Detection Status	R	0h	HPCOM short-circuit detection status. 0: No short circuit detected at HPCOM driver 1: Short circuit detected at HPCOM driver
3	Reserved	R	0h	Reserved. Always write zero to this bit.
2	Headset Detection Status	R	0h	Headset detection status. 0: No headset insertion or removal is detected 1: Headset insertion or removal is detected
1	ADC AGC Noise Gate Status	R	0h	ADC AGC noise gate status. 0: DC signal power is greater than or equal to noise threshold for AGC 1: ADC signal power is less than noise threshold for AGC
0	Reserved	R	0h	Reserved. Always write zero to this bit.

7.6.2.78 Register 97: Real-Time Interrupt Flags Register (address = 61h) [reset = 0000 0000], Page 0
Figure 108. Register 97

7	6	5	4	3	2	1	0
0	HPOUT Short-Circuit Detection Status	0	HPCOM Short-Circuit Detection Status	0	Headset Detection Status	ADC AGC Noise Gate Status	0
R-0h	R-0h	R-0h	R-0h	R-0h	R-0h	R-0h	R-0h

Table 86. Register 97 Field Descriptions

Bit	Field	Type	Reset	Description
7	Reserved	R	0h	Reserved. Always write zero to this bit.
6	HPOUT Short-Circuit Detection Status	R	0h	HPOUT short-circuit detection status. 0: No short circuit detected at HPOUT driver 1: Short circuit detected at HPOUT driver
5	Reserved	R	0h	Reserved. Always write zero to this bit.
4	HPCOM Short-Circuit Detection Status	R	0h	HPCOM short-circuit detection status. 0: No short circuit detected at HPCOM driver 1: Short circuit detected at HPCOM driver
3	Reserved	R	0h	Reserved. Always write zero to this bit.
2	Headset Detection Status	R	0h	Headset Detection Status 0: No headset insertion/removal is detected. 1: Headset insertion/removal is detected.
1	ADC AGC Noise Gate Status	R	0h	ADC AGC Noise Gate Status 0: ADC signal power is greater than noise threshold for IAGC. 1: ADC signal power lower than noise threshold for AGC.
0	Reserved	R	0h	Reserved. Always write zero to this bit.

7.6.2.79 Registers 98–100: Reserved (address = 62h–64h) [reset = 0000 0000], Page 0
Figure 109. Registers 98–100

7	6	5	4	3	2	1	0
0	0	0	0	0	0	0	0
R-0h	R-0h	R-0h	R-0h	R-0h	R-0h	R-0h	R-0h

Table 87. Registers 98–100 Field Descriptions

Bit	Field	Type	Reset	Description
7:0	Reserved	R	0h	Reserved. Always write zeros to these bits.

7.6.2.80 Register 101: Clock Register (address = 65h) [reset = 0000 0000], Page 0
Figure 110. Register 101

7	6	5	4	3	2	1	0
0	0	0	0	0	0	0	CODEC_CLKIN Source Selection
R-0h	R-0h	R-0h	R-0h	R-0h	R-0h	R-0h	R/W-0h

Table 88. Register 101 Field Descriptions

Bit	Field	Type	Reset	Description
7:1	Reserved	R	0h	Reserved. Always write zeros to these bits.
0	CODEC_CLKIN Source Selection	R/W	0h	CODEC_CLKIN source selection. 0: CODEC_CLKIN uses PLLDIV_OUT 1: CODEC_CLKIN uses CLKDIV_OUT

7.6.2.81 Register 102: Clock Generation Control Register (address = 66h) [reset = 0000 0000], Page 0

Figure 111. Register 102

7	6	5	4	3	2	1	0
CLKDIV_IN Source Selection	PLLCLK_IN Source Selection		0	0	1	0	
R/W-0h	R/W-0h		R/W-0h	R/W-0h	R/W-0h	R/W-0h	R/W-0h

Table 89. Register 102 Field Descriptions

Bit	Field	Type	Reset	Description
7:6	CLKDIV_IN Source Selection	R/W	0h	CLKDIV_IN source selection. 00: CLKDIV_IN uses MCLK 01: CLKDIV_IN uses GPIO2 10: CLKDIV_IN uses BCLK 11: Reserved; do not use
5:4	PLLCLK_IN Source Selection	R/W	0h	PLLCLK_IN source selection. 00: PLLCLK_IN uses MCLK 01: PLLCLK_IN uses GPIO2 10: PLLCLK_IN uses BCLK 11: Reserved; do not use
3:0	Reserved	R/W	0h	Reserved. Always write zeros to these bits.

7.6.2.82 Register 103: AGC New Programmable Attack Time Register (address = 67h) [reset = 0000 0000], Page 0

Figure 112. Register 103

7	6	5	4	3	2	1	0
Attack Time Register Selection	Baseline AGC Attack Time		Multiplication Factor for Baseline AGC			0	0
R/W-0h	R/W-0h		R/W-0h			R/W-0h	R/W-0h

Table 90. Register 103 Field Descriptions

Bit	Field	Type	Reset	Description
7	Attack Time Register Selection	R/W	0h	Attack time register selection. 0: Attack time for the AGC is generated from register 26, page 0 1: Attack time for the AGC is generated from this register
6:5	Baseline AGC Attack Time	R/W	0h	Baseline AGC attack time. 00: AGC attack time = 7 ms 01: AGC attack time = 8 ms 10: AGC attack time = 10 ms 11: AGC attack time = 11 ms
4:2	Multiplication Factor for Baseline AGC	R/W	0h	Multiplication factor for baseline AGC. 000: Multiplication factor for the baseline AGC attack time = 1 001: Multiplication factor for the baseline AGC attack time = 2 010: Multiplication factor for the baseline AGC attack time = 4 011: Multiplication factor for the baseline AGC attack time = 8 100: Multiplication factor for the baseline AGC attack time = 16 101: Multiplication factor for the baseline AGC attack time = 32 110: Multiplication factor for the baseline AGC attack time = 64 111: Multiplication factor for the baseline AGC attack time = 128
1:0	Reserved	R/W	0h	Reserved. Always write zeros to these bits.

7.6.2.83 Register 104: AGC New Programmable Decay Time Register (address = 68h) [reset = 0000 0000], Page 0
Figure 113. Register 104

7	6	5	4	3	2	1	0
Decay Time Register Selection	Baseline AGC Decay Time		Multiplication Factor for Baseline AGC			0	0
R/W-0h	R/W-0h		R/W-0h			R/W-0h	R/W-0h

Table 91. Register 104 Field Descriptions

Bit	Field	Type	Reset	Description
7	Decay Time Register Selection ⁽¹⁾	R/W	0h	Decay time register selection. 0: Decay time for the AGC is generated from register 26, page 0 1: Decay time for the AGC is generated from this register
6:5	Baseline AGC Decay Time	R/W	0h	Baseline AGC decay time. 00: AGC decay time = 50 ms 01: AGC decay time = 150 ms 10: AGC decay time = 250 ms 11: -AGC decay time = 350 ms
4:2	Multiplication Factor for Baseline AGC	R/W	0h	Multiplication factor for baseline AGC. 000: Multiplication factor for the baseline AGC decay time = 1 001: Multiplication factor for the baseline AGC decay time = 2 010: Multiplication factor for the baseline AGC decay time = 4 011: Multiplication factor for the baseline AGC decay time = 8 100: Multiplication factor for the baseline AGC decay time = 16 101: Multiplication factor for the baseline AGC decay time = 32 110: Multiplication factor for the baseline AGC decay time = 64 111: Multiplication factor for the baseline AGC decay time = 128
1:0	Reserved	R/W	0h	Reserved. Always write zeros to these bits.

- (1) Decay time is limited based on the NCODEC ratio that is selected. For NCODEC = 1, maximum decay time = 4 s; NCODEC = 1.5, maximum decay time = 5.6 s; NCODEC = 2, maximum decay time = 8 s; NCODEC = 2.5, maximum decay time = 9.6 s; NCODEC = 3 or 3.5, maximum decay time = 11.2 s; NCODEC = 4 or 4.5, maximum decay time = 16 s; NCODEC = 5, maximum decay time = 19.2 s; and NCODEC = 5.5 or 6, maximum decay time = 22.4 s.

7.6.2.84 Registers 105–106: Reserved (address = 69h–6Ah) [reset = 0000 0000], Page 0
Figure 114. Register 105

7	6	5	4	3	2	1	0
0	0	0	0	0	0	0	0
R/W-0h	R/W-0h	R/W-0h	R/W-0h	R/W-0h	R/W-0h	R/W-0h	R/W-0h

Table 92. Register 105 Field Descriptions

Bit	Field	Type	Reset	Description
7:0	Reserved	R/W	0h	Reserved. Always write zeros to these bits.

7.6.2.85 Register 107: New Programmable ADC Digital Path and I²C Bus Condition Register (address = 6Bh) [reset = 0000 0000], Page 0
Figure 115. Register 107

7	6	5	4	3	2	1	0
Channel High-Pass Filter Coefficient Selection	0	0	0	ADC Digital Output to Programmable Filter Path Selection	I ² C Bus Condition Detector	0	I ² C Bus Error Detection Status
R/W-0h	R/W-0h	R/W-0h	R/W-0h	R/W-0h	R/W-0h	R-0h	R-0h

Table 93. Register 107 Field Descriptions

Bit	Field	Type	Reset	Description
7	Channel High-Pass Filter Coefficient Selection	R/W	0h	Channel high-pass filter coefficient selection. 0: Default coefficients are used when ADC high pass is enabled 1: Programmable coefficients are used when ADC high pass is enabled
6:4	Reserved	R/W	0h	Reserved. Always write zeros to these bits.
3	ADC Digital Output to Programmable Filter Path Selection	R/W	0h	ADC digital output to programmable filter path selection. 0: No additional programmable filters other than the HPF are used for the ADC 1: The programmable filter is connected to the ADC output if both DACs are powered down
2	I ² C Bus Condition Detector	R/W	0h	I ² C bus condition detector. 0: Internal logic is enabled to detect an I ² C bus error and clears the bus error condition 1: Internal logic is disabled to detect an I ² C bus error
1	Reserved	R	0h	Reserved. Always write zero to this bit
0	I ² C Bus Error Detection Status	R	0h	I ² C bus error detection status. 0: I ² C bus error is not detected 1: I ² C bus error is detected; this bit is cleared by reading this register

7.6.2.86 Register 108: Passive Analog Signal Bypass Selection During Power Down Register (address = 6Ch) [reset = 0000 0000], Page 0
Figure 116. Register 108

7	6	5	4	3	2	1	0
0	0	LINE1RM Path Selection	LINE1RP Path Selection	0	0	LINE1LM Path Selection	LINE1LP Path Selection
R/W-0h	R/W-0h	R/W-0h	R/W-0h	R/W-0h	R/W-0h	R/W-0h	R/W-0h

Table 94. Register 108 Field Descriptions⁽¹⁾

Bit	Field	Type	Reset	Description
7:6	Reserved	R/W	0h	Reserved. Always write zeros to these bits.
5	LINE1RM Path Selection	R/W	0h	LINE1RM path selection. 0: Normal signal path 1: Signal is routed by a switch to RIGHT_LOM
4	LINE1RP Path Selection	R/W	0h	LINE1RP path selection. 0: Normal signal path 1: Signal is routed by a switch to RIGHT_LOP
3:2	Reserved	R/W	0h	Reserved. Always write zeros to these bits
1	LINE1LM Path Selection	R/W	0h	LINE1LM path selection. 0: Normal signal path 1: Signal is routed by a switch to LEFT_LOM
0	LINE1LP Path Selection	R/W	0h	LINE1LP path selection. 0: Normal signal path 1: Signal is routed by a switch to LEFT_LOP

(1) Based on the register 108 settings, if both LINE1 and LINE2 inputs are routed to the output at the same time, then the two switches used for the connection short the two input signals together on the output pins. The shorting resistance between the two input pins is two times the bypass switch resistance (R_{dson}). In general, avoid this shorting condition because higher drive currents are likely to occur on the circuitry that feeds these two input pins of this device.

7.6.2.87 Register 109: DAC Quiescent Current Adjustment Register (address = 6Dh) [reset = 0000 0000], Page 0
Figure 117. Register 109

7	6	5	4	3	2	1	0
DAC Current Adjustment		0	0	0	0	0	0
R/W-0h		R/W-0h	R/W-0h	R/W-0h	R/W-0h	R/W-0h	R/W-0h

Table 95. Register 109 Field Descriptions

Bit	Field	Type	Reset	Description
7:8	DAC Current Adjustment	R/W	0h	DAC current adjustment. 00: Default 01: 50% increase in DAC reference current 10: Reserved 11: 100% increase in DAC reference current
5:0	Reserved	R/W	0h	Reserved. Always write zeros to these bits.

7.6.2.88 Registers 110–127: Reserved (address = 6Eh–7Fh) [reset = 0000 0000], Page 0
Figure 118. Registers 110–127

7	6	5	4	3	2	1	0
0	0	0	0	0	0	0	0
R-0h	R-0h	R-0h	R-0h	R-0h	R-0h	R-0h	R-0h

Table 96. Registers 110–127 Field Descriptions

Bit	Field	Type	Reset	Description
7:0	Reserved	R	0h	Reserved. Always write zeros to these bits.

7.6.3 Page 1 Register Descriptions

These registers are held within page 1.

7.6.3.1 Register 0: Page Select Register (address = 0h) [reset = 0000 0000], Page 1
Figure 119. Register 0

7	6	5	4	3	2	1	0
0	0	0	0	0	0	0	Page Select Bit
X-0h	X-0h	X-0h	X-0h	X-0h	X-0h	X-0h	R/W-0h

Table 97. Register 0 Field Descriptions

Bit	Field	Type	Reset	Description
7:1	Reserved	X	0h	Reserved. Always write zeros to these bits.
0	Page Select Bit	R/W	0h	Page select bit. Writing zero to this bit sets page 0 as the active page for following register accesses. Writing a one to this bit sets page 1 as the active page for following register accesses. This register bit is recommended to be read back after each write to ensure that the proper page is being accessed for future register read/writes. This register has the same functionality on page 0 and page 1.

7.6.3.2 Register 1: Audio Effects Filter N0 Coefficient MSB Register (address = 1h) [reset = 0110 1011], Page 1
Figure 120. Register 1

7	6	5	4	3	2	1	0
Audio Effects Filter N0 Coefficient MSB							
R/W-0h	R/W-1h	R/W-1h	R/W-0h	R/W-1h	R/W-0h	R/W-1h	R/W-1h

Table 98. Register 1 Field Descriptions

Bit	Field	Type	Reset	Description
7:0	Audio Effects Filter N0 Coefficient MSB ⁽¹⁾	R/W	0110 1011h	Audio effects filter N0 coefficient MSB. The 16-bit integer contained in the MSB and LSB registers for this coefficient are interpreted as a 2's-complement integer with possible values ranging from –32,768 to 32,767.

(1) When programming any coefficient value in page 1, always write the MSB register first, immediately followed by the LSB register. Even if only the MSB or LSB of the coefficient changes, write both registers in this sequence.

**7.6.3.3 Register 2: Audio Effects Filter N0 Coefficient LSB Register (address = 2h) [reset = 1110 0011],
Page 1**
Figure 121. Register 2

7	6	5	4	3	2	1	0
Audio Effects Filter N0 Coefficient LSB							
R/W-1h	R/W-1h	R/W-1h	R/W-0h	R/W-0h	R/W-0h	R/W-1h	R/W-1h

Table 99. Register 2 Field Descriptions

Bit	Field	Type	Reset	Description
7:0	Audio Effects Filter N0 Coefficient LSB	R/W	1110 0011h	Audio effects filter N0 coefficient LSB. The 16-bit integer contained in the MSB and LSB registers for this coefficient are interpreted as a 2's-complement integer with possible values ranging from –32,768 to 32,767.

**7.6.3.4 Register 3: Audio Effects Filter N1 Coefficient MSB Register (address = 3h) [reset = 1001 0110],
Page 1**
Figure 122. Register 3

7	6	5	4	3	2	1	0
Audio Effects Filter N1 Coefficient MSB							
R/W-1h	R/W-0h	R/W-0h	R/W-1h	R/W-0h	R/W-1h	R/W-1h	R/W-0h

Table 100. Register 3 Field Descriptions

Bit	Field	Type	Reset	Description
7:0	Audio Effects Filter N1 Coefficient MSB	R/W	1001 0110h	Audio effects filter N1 coefficient MSB. The 16-bit integer contained in the MSB and LSB registers for this coefficient are interpreted as a 2's-complement integer with possible values ranging from –32,768 to 32,767.

**7.6.3.5 Register 4: Audio Effects Filter N1 Coefficient LSB Register (address = 4h) [reset = 0110 0110],
Page 1**
Figure 123. Register 4

7	6	5	4	3	2	1	0
Audio Effects Filter N1 Coefficient LSB							
R/W-0h	R/W-1h	R/W-1h	R/W-0h	R/W-0h	R/W-1h	R/W-1h	R/W-0h

Table 101. Register 4 Field Descriptions

Bit	Field	Type	Reset	Description
7:0	Audio Effects Filter N1 Coefficient LSB	R/W	0110 0110h	Audio effects filter N1 coefficient LSB. The 16-bit integer contained in the MSB and LSB registers for this coefficient are interpreted as a 2's-complement integer with possible values ranging from –32,768 to 32,767.

7.6.3.6 Register 5: Audio Effects Filter N2 Coefficient MSB Register (address = 5h) [reset = 0110 0111], Page 1

Figure 124. Register 5

7	6	5	4	3	2	1	0
Audio Effects Filter N2 Coefficient MSB							
R/W-0h	R/W-1h	R/W-1h	R/W-0h	R/W-0h	R/W-1h	R/W-1h	R/W-1h

Table 102. Register 5 Field Descriptions

Bit	Field	Type	Reset	Description
7:0	Audio Effects Filter N2 Coefficient MSB	R/W	0110 0111h	Audio effects filter N2 coefficient MSB. The 16-bit integer contained in the MSB and LSB registers for this coefficient are interpreted as a 2's-complement integer with possible values ranging from –32,768 to 32,767.

7.6.3.7 Register 6: Audio Effects Filter N2 Coefficient LSB Register (address = 6h) [reset = 0101 1101], Page 1

Figure 125. Register 6

7	6	5	4	3	2	1	0
Audio Effects Filter N2 Coefficient LSB							
R/W-0h	R/W-1h	R/W-0h	R/W-1h	R/W-1h	R/W-1h	R/W-0h	R/W-1h

Table 103. Register 6 Field Descriptions

Bit	Field	Type	Reset	Description
7:0	Audio Effects Filter N2 Coefficient LSB	R/W	0101 1101h	Audio effects filter N2 coefficient LSB. The 16-bit integer contained in the MSB and LSB registers for this coefficient are interpreted as a 2's-complement integer with possible values ranging from –32,768 to 32,767.

7.6.3.8 Register 7: Audio Effects Filter N3 Coefficient MSB Register (address = 7h) [reset = 0110 1011], Page 1

Figure 126. Register 7

7	6	5	4	3	2	1	0
Audio Effects Filter N3 Coefficient MSB							
R/W-0h	R/W-1h	R/W-1h	R/W-0h	R/W-1h	R/W-0h	R/W-1h	R/W-1h

Table 104. Register 7 Field Descriptions

Bit	Field	Type	Reset	Description
7:0	Audio Effects Filter N3 Coefficient MSB	R/W	0110 1011h	Audio effects filter N3 coefficient MSB. The 16-bit integer contained in the MSB and LSB registers for this coefficient are interpreted as a 2's-complement integer with possible values ranging from –32,768 to 32,767.

**7.6.3.9 Register 8: Audio Effects Filter N3 Coefficient LSB Register (address = 8h) [reset = 1110 0011],
Page 1**
Figure 127. Register 8

7	6	5	4	3	2	1	0
Audio Effects Filter N3 Coefficient LSB							
R/W-1h	R/W-1h	R/W-1h	R/W-0h	R/W-0h	R/W-0h	R/W-1h	R/W-1h

Table 105. Register 8 Field Descriptions

Bit	Field	Type	Reset	Description
7:0	Audio Effects Filter N3 Coefficient LSB	R/W	1110 0011h	Audio effects filter N3 coefficient LSB. The 16-bit integer contained in the MSB and LSB registers for this coefficient are interpreted as a 2's-complement integer with possible values ranging from –32,768 to 32,767.

**7.6.3.10 Register 9: Audio Effects Filter N4 Coefficient MSB Register (address = 9h) [reset = 1001 0110],
Page 1**
Figure 128. Register 9

7	6	5	4	3	2	1	0
Audio Effects Filter N4 Coefficient MSB							
R/W-1h	R/W-0h	R/W-0h	R/W-1h	R/W-0h	R/W-1h	R/W-1h	R/W-0h

Table 106. Register 9 Field Descriptions

Bit	Field	Type	Reset	Description
7:0	Audio Effects Filter N4 Coefficient MSB	R/W	1001 0110h	Audio effects filter N4 coefficient MSB. The 16-bit integer contained in the MSB and LSB registers for this coefficient are interpreted as a 2's-complement integer with possible values ranging from –32,768 to 32,767.

**7.6.3.11 Register 10: Audio Effects Filter N4 Coefficient LSB Register (address = Ah) [reset = 0110 0110],
Page 1**
Figure 129. Register 10

7	6	5	4	3	2	1	0
Audio Effects Filter N4 Coefficient LSB							
R/W-0h	R/W-1h	R/W-1h	R/W-0h	R/W-0h	R/W-1h	R/W-1h	R/W-0h

Table 107. Register 10 Field Descriptions

Bit	Field	Type	Reset	Description
7:0	Audio Effects Filter N4 Coefficient LSB	R/W	0110 0110h	Audio effects filter N4 coefficient LSB. The 16-bit integer contained in the MSB and LSB registers for this coefficient are interpreted as a 2's-complement integer with possible values ranging from –32,768 to 32,767.

7.6.3.12 Register 11: Audio Effects Filter N5 Coefficient MSB Register (address = Bh) [reset = 0110 0111], Page 1
Figure 130. Register 11

7	6	5	4	3	2	1	0
Audio Effects Filter N5 Coefficient MSB							
R/W-0h	R/W-1h	R/W-1h	R/W-0h	R/W-0h	R/W-1h	R/W-1h	R/W-1h

Table 108. Register 11 Field Descriptions

Bit	Field	Type	Reset	Description
7:0	Audio Effects Filter N5 Coefficient MSB	R/W	0110 0111h	Audio effects filter N5 coefficient MSB. The 16-bit integer contained in the MSB and LSB registers for this coefficient are interpreted as a 2's-complement integer with possible values ranging from –32,768 to 32,767.

7.6.3.13 Register 12: Audio Effects Filter N5 Coefficient LSB Register (address = Ch) [reset = 0101 1101], Page 1
Figure 131. Register 12

7	6	5	4	3	2	1	0
Audio Effects Filter N5 Coefficient LSB							
R/W-0h	R/W-1h	R/W-0h	R/W-1h	R/W-1h	R/W-1h	R/W-0h	R/W-1h

Table 109. Register 12 Field Descriptions

Bit	Field	Type	Reset	Description
7:0	Audio Effects Filter N5 Coefficient LSB	R/W	0101 1101h	Audio effects filter N5 coefficient LSB. The 16-bit integer contained in the MSB and LSB registers for this coefficient are interpreted as a 2's-complement integer with possible values ranging from –32,768 to 32,767.

7.6.3.14 Register 13: Audio Effects Filter D1 Coefficient MSB Register (address = Dh) [reset = 0111 1101], Page 1
Figure 132. Register 13

7	6	5	4	3	2	1	0
Audio Effects Filter D1 Coefficient MSB							
R/W-0h	R/W-1h	R/W-1h	R/W-1h	R/W-1h	R/W-1h	R/W-0h	R/W-1h

Table 110. Register 13 Field Descriptions

Bit	Field	Type	Reset	Description
7:0	Audio Effects Filter D1 Coefficient MSB	R/W	0111 1101h	Audio effects filter D1 coefficient MSB. The 16-bit integer contained in the MSB and LSB registers for this coefficient are interpreted as a 2's-complement integer with possible values ranging from –32,768 to 32,767.

7.6.3.15 Register 14: Audio Effects Filter D1 Coefficient LSB Register (address = Eh) [reset = 1000 0011h], Page 1
Figure 133. Register 14

7	6	5	4	3	2	1	0
Audio Effects Filter D1 Coefficient LSB							
R/W-1h	R/W-0h	R/W-0h	R/W-0h	R/W-0h	R/W-0h	R/W-1h	R/W-1h

Table 111. Register 14 Field Descriptions

Bit	Field	Type	Reset	Description
7:0	Audio Effects Filter D1 Coefficient LSB	R/W	1000 0011h	Audio effects filter D1 coefficient LSB. The 16-bit integer contained in the MSB and LSB registers for this coefficient are interpreted as a 2's-complement integer with possible values ranging from –32,768 to 32,767.

7.6.3.16 Register 15: Audio Effects Filter D2 Coefficient MSB Register (address = Fh) [reset = 1000 0100], Page 1
Figure 134. Register 15

7	6	5	4	3	2	1	0
Audio Effects Filter D2 Coefficient MSB							
R/W-1h	R/W-0h	R/W-0h	R/W-0h	R/W-0h	R/W-1h	R/W-0h	R/W-0h

Table 112. Register 15 Field Descriptions

Bit	Field	Type	Reset	Description
7:0	Audio Effects Filter D2 Coefficient MSB	R/W	1000 0100h	Audio effects filter D2 coefficient MSB. The 16-bit integer contained in the MSB and LSB registers for this coefficient are interpreted as a 2's-complement integer with possible values ranging from –32,768 to 32,767.

7.6.3.17 Register 16: Audio Effects Filter D2 Coefficient LSB Register (address = 10h) [reset = 1110 1110], Page 1
Figure 135. Register 16

7	6	5	4	3	2	1	0
Audio Effects Filter D2 Coefficient LSB							
R/W-1h	R/W-1h	R/W-1h	R/W-0h	R/W-1h	R/W-1h	R/W-1h	R/W-0h

Table 113. Register 16 Field Descriptions

Bit	Field	Type	Reset	Description
7:0	Audio Effects Filter D2 Coefficient LSB	R/W	1110 1110h	Audio effects filter D2 coefficient LSB. The 16-bit integer contained in the MSB and LSB registers for this coefficient are interpreted as a 2's-complement integer with possible values ranging from –32,768 to 32,767.

7.6.3.18 Register 17: Audio Effects Filter D4 Coefficient MSB Register (address = 11h) [reset = 0111 1101], Page 1
Figure 136. Register 17

7	6	5	4	3	2	1	0
Audio Effects Filter D4 Coefficient MSB							
R/W-0h	R/W-1h	R/W-1h	R/W-1h	R/W-1h	R/W-1h	R/W-0h	R/W-1h

Table 114. Register 17 Field Descriptions

Bit	Field	Type	Reset	Description
7:0	Audio Effects Filter D4 Coefficient MSB	R/W	0111 1101h	Audio effects filter D4 coefficient MSB. The 16-bit integer contained in the MSB and LSB registers for this coefficient are interpreted as a 2's-complement integer with possible values ranging from –32,768 to 32,767.

7.6.3.19 Register 18: Audio Effects Filter D4 Coefficient LSB Register (address = 12h) [reset = 1000 0011], Page 1
Figure 137. Register 18

7	6	5	4	3	2	1	0
Audio Effects Filter D4 Coefficient LSB							
R/W-1h	R/W-0h	R/W-0h	R/W-0h	R/W-0h	R/W-0h	R/W-1h	R/W-1h

Table 115. Register 18 Field Descriptions

Bit	Field	Type	Reset	Description
7:0	Audio Effects Filter D4 Coefficient LSB	R/W	1000 0011h	Audio effects filter D4 coefficient LSB. The 16-bit integer contained in the MSB and LSB registers for this coefficient are interpreted as a 2's-complement integer with possible values ranging from –32,768 to 32,767.

7.6.3.20 Register 19: Audio Effects Filter D5 Coefficient MSB Register (address = 13h) [reset = 1000 0100], Page 1
Figure 138. Register 19

7	6	5	4	3	2	1	0
Audio Effects Filter D5 Coefficient MSB							
R/W-1h	R/W-0h	R/W-0h	R/W-0h	R/W-0h	R/W-1h	R/W-0h	R/W-0h

Table 116. Register 19 Field Descriptions

Bit	Field	Type	Reset	Description
7:0	Audio Effects Filter D5 Coefficient MSB	R/W	1000 0100h	Audio effects filter D5 coefficient MSB. The 16-bit integer contained in the MSB and LSB registers for this coefficient are interpreted as a 2's-complement integer with possible values ranging from –32,768 to 32,767.

7.6.3.21 Register 20: Audio Effects Filter D5 Coefficient LSB Register (address = 14h) [reset = 1110 1110], Page 1
Figure 139. Register 20

7	6	5	4	3	2	1	0
Audio Effects Filter D5 Coefficient LSB							
R/W-1h	R/W-1h	R/W-1h	R/W-0h	R/W-1h	R/W-1h	R/W-1h	R/W-0h

Table 117. Register 20 Field Descriptions

Bit	Field	Type	Reset	Description
7:0	Audio Effects Filter D5 Coefficient LSB	R/W	1110 1110h	Audio effects filter D5 coefficient LSB. The 16-bit integer contained in the MSB and LSB registers for this coefficient are interpreted as a 2's-complement integer with possible values ranging from –32,768 to 32,767.

7.6.3.22 Register 21: De-Emphasis Filter N0 Coefficient MSB Register (address = 15h) [reset = 0011 1001], Page 1
Figure 140. Register 21

7	6	5	4	3	2	1	0
De-Emphasis Filter N0 Coefficient MSB							
R/W-0h	R/W-0h	R/W-1h	R/W-1h	R/W-1h	R/W-0h	R/W-0h	R/W-1h

Table 118. Register 21 Field Descriptions

Bit	Field	Type	Reset	Description
7:0	De-Emphasis Filter N0 Coefficient MSB	R/W	0011 1001h	De-emphasis filter N0 coefficient MSB. The 16-bit integer contained in the MSB and LSB registers for this coefficient are interpreted as a 2's-complement integer with possible values ranging from –32,768 to 32,767.

7.6.3.23 Register 22: De-Emphasis Filter N0 Coefficient LSB Register (address = 16h) [reset = 0101 0101], Page 1
Figure 141. Register 22

7	6	5	4	3	2	1	0
De-Emphasis Filter N0 Coefficient LSB							
R/W-0h	R/W-1h	R/W-0h	R/W-1h	R/W-0h	R/W-1h	R/W-0h	R/W-1h

Table 119. Register 22 Field Descriptions

Bit	Field	Type	Reset	Description
7:0	De-Emphasis Filter N0 Coefficient LSB	R/W	0101 0101h	De-emphasis filter N0 coefficient LSB. The 16-bit integer contained in the MSB and LSB registers for this coefficient are interpreted as a 2's-complement integer with possible values ranging from –32,768 to 32,767.

7.6.3.24 Register 23: De-Emphasis Filter N1 Coefficient MSB Register (address = 17h) [reset = 1111 0011], Page 1
Figure 142. Register 23

7	6	5	4	3	2	1	0
De-Emphasis Filter N1 Coefficient MSB							
R/W-1h	R/W-1h	R/W-1h	R/W-1h	R/W-0h	R/W-0h	R/W-1h	R/W-1h

Table 120. Register 23 Field Descriptions

Bit	Field	Type	Reset	Description
7:0	De-Emphasis Filter N1 Coefficient MSB	R/W	1111 0011h	De-emphasis filter N1 coefficient MSB. The 16-bit integer contained in the MSB and LSB registers for this coefficient are interpreted as a 2's-complement integer with possible values ranging from –32,768 to 32,767.

7.6.3.25 Register 24: De-Emphasis Filter N1 Coefficient LSB Register (address = 18h) [reset = 0010 1101], Page 1
Figure 143. Register 24

7	6	5	4	3	2	1	0
De-Emphasis Filter N1 Coefficient LSB							
R/W-0h	R/W-0h	R/W-1h	R/W-0h	R/W-1h	R/W-1h	R/W-0h	R/W-1h

Table 121. Register 24 Field Descriptions

Bit	Field	Type	Reset	Description
7:0	De-Emphasis Filter N1 Coefficient LSB	R/W	0010 1101h	De-emphasis filter N1 coefficient LSB. The 16-bit integer contained in the MSB and LSB registers for this coefficient are interpreted as a 2's-complement integer with possible values ranging from –32,768 to 32,767.

7.6.3.26 Register 25: De-Emphasis Filter D1 Coefficient MSB Register (address = 19h) [reset = 0101 0011], Page 1
Figure 144. Register 25

7	6	5	4	3	2	1	0
De-Emphasis Filter D1 Coefficient MSB							
R/W-0h	R/W-1h	R/W-0h	R/W-1h	R/W-0h	R/W-0h	R/W-1h	R/W-1h

Table 122. Register 25 Field Descriptions

Bit	Field	Type	Reset	Description
7:0	De-Emphasis Filter D1 Coefficient MSB	R/W	0101 0011h	De-emphasis filter D1 coefficient MSB. The 16-bit integer contained in the MSB and LSB registers for this coefficient are interpreted as a 2's-complement integer with possible values ranging from –32,768 to 32,767.

7.6.3.27 Register 26: De-Emphasis Filter D1 Coefficient LSB Register (address = 1Ah) [reset = 0111 1110], Page 1
Figure 145. Register 26

7	6	5	4	3	2	1	0
De-Emphasis Filter D1 Coefficient LSB							
R/W-0h	R/W-1h	R/W-1h	R/W-1h	R/W-1h	R/W-1h	R/W-1h	R/W-0h

Table 123. Register 26 Field Descriptions

Bit	Field	Type	Reset	Description
7:0	De-Emphasis Filter D1 Coefficient LSB	R/W	0111 1110h	De-emphasis filter D1 coefficient LSB. The 16-bit integer contained in the MSB and LSB registers for this coefficient are interpreted as a 2's-complement integer with possible values ranging from –32,768 to 32,767.

7.6.3.28 Register 27: Reserved (address = 1Bh) [reset = 0110 1011], Page 1
Figure 146. Register 27

7	6	5	4	3	2	1	0
0	1	1	0	1	0	1	1
R/W-0h	R/W-1h	R/W-1h	R/W-0h	R/W-1h	R/W-0h	R/W-1h	R/W-1h

Table 124. Register 27 Field Descriptions

Bit	Field	Type	Reset	Description
7:0	Reserved	R/W	0110 1011h	Reserved. Always write 0110 1011 to these bits.

7.6.3.29 Register 28: Reserved (address = 1Ch) [reset = 1110 0011], Page 1
Figure 147. Register 28

7	6	5	4	3	2	1	0
1	1	1	0	0	0	1	1
R/W-1h	R/W-1h	R/W-1h	R/W-0h	R/W-0h	R/W-0h	R/W-1h	R/W-1h

Table 125. Register 28 Field Descriptions

Bit	Field	Type	Reset	Description
7:0	Reserved	R/W	1110 0011h	Reserved. Always write 1110 0011 to these bits.

7.6.3.30 Register 29: Reserved (address = 1Dh) [reset = 1001 0110], Page 1
Figure 148. Register 29

7	6	5	4	3	2	1	0
1	0	0	1	0	1	1	0
R/W-1h	R/W-0h	R/W-0h	R/W-1h	R/W-0h	R/W-1h	R/W-1h	R/W-0h

Table 126. Register 29 Field Descriptions

Bit	Field	Type	Reset	Description
7:0	Reserved	R/W	1001 0110h	Reserved. Always write 1001 0110 to these bits.

7.6.3.31 Register 30: Reserved (address = 1Eh) [reset = 0110 0110], Page 1
Figure 149. Register 30

7	6	5	4	3	2	1	0
0	1	1	0	0	1	1	0
R/W-0h	R/W-1h	R/W-1h	R/W-0h	R/W-0h	R/W-1h	R/W-1h	R/W-0h

Table 127. Register 30 Field Descriptions

Bit	Field	Type	Reset	Description
7:0	Reserved	R/W	0110 0110h	Reserved. Always write 0110 0110 to these bits.

7.6.3.32 Register 31: Reserved (address = 1Fh) [reset = 0110 0111], Page 1
Figure 150. Register 31

7	6	5	4	3	2	1	0
0	1	1	0	0	1	1	1
R/W-0h	R/W-1h	R/W-1h	R/W-0h	R/W-0h	R/W-1h	R/W-1h	R/W-1h

Table 128. Register 31 Field Descriptions

Bit	Field	Type	Reset	Description
7:0	Reserved	R/W	0110 0111h	Reserved. Always write 0110 0111 to these bits.

7.6.3.33 Register 32: Reserved (address = 20h) [reset = 0101 1101], Page 1
Figure 151. Register 32

7	6	5	4	3	2	1	0
0	1	0	1	1	1	0	1
R/W-0h	R/W-1h	R/W-0h	R/W-1h	R/W-1h	R/W-1h	R/W-0h	R/W-1h

Table 129. Register 32 Field Descriptions

Bit	Field	Type	Reset	Description
7:0	Reserved	R/W	0101 1101h	Reserved. Always write 0101 1101 to these bits.

7.6.3.34 Register 33: Reserved (address = 21h) [reset = 0110 1011], Page 1
Figure 152. Register 33

7	6	5	4	3	2	1	0
0	1	1	0	1	0	1	1
R/W-0h	R/W-1h	R/W-1h	R/W-0h	R/W-1h	R/W-0h	R/W-1h	R/W-1h

Table 130. Register 33 Field Descriptions

Bit	Field	Type	Reset	Description
7:0	Reserved	R/W	0110 1011h	Reserved. Always write 0110 1011 to these bits.

7.6.3.35 Register 34: Reserved (address = 22h) [reset = 1110 0011], Page 1
Figure 153. Register 34

7	6	5	4	3	2	1	0
1	1	1	0	0	0	1	1
R/W-1h	R/W-1h	R/W-1h	R/W-0h	R/W-0h	R/W-0h	R/W-1h	R/W-1h

Table 131. Register 34 Field Descriptions

Bit	Field	Type	Reset	Description
7:0	Reserved	R/W	1110 0011h	Reserved. Always write 1110 0011 to these bits.

7.6.3.36 Register 35: Reserved (address = 23h) [reset = 1001 0110], Page 1
Figure 154. Register 35

7	6	5	4	3	2	1	0
1	0	0	1	0	1	1	0
R/W-1h	R/W-0h	R/W-0h	R/W-1h	R/W-0h	R/W-1h	R/W-1h	R/W-0h

Table 132. Register 35 Field Descriptions

Bit	Field	Type	Reset	Description
7:0	Reserved	R/W	1001 0110h	Reserved. Always write 1001 0110 to these bits.

7.6.3.37 Register 36: Reserved (address = 24h) [reset = 0110 0110], Page 1
Figure 155. Register 36

7	6	5	4	3	2	1	0
0	1	1	0	0	1	1	0
R/W-0h	R/W-1h	R/W-1h	R/W-0h	R/W-0h	R/W-1h	R/W-1h	R/W-0h

Table 133. Register 36 Field Descriptions

Bit	Field	Type	Reset	Description
7:0	Reserved	R/W	0110 0110h	Reserved. Always write 0110 0110 to these bits.

7.6.3.38 Register 37: Reserved (address = 25h) [reset = 0110 0111], Page 1
Figure 156. Register 37

7	6	5	4	3	2	1	0
0	1	1	0	0	1	1	1
R/W-0h	R/W-1h	R/W-1h	R/W-0h	R/W-0h	R/W-1h	R/W-1h	R/W-1h

Table 134. Register 37 Field Descriptions

Bit	Field	Type	Reset	Description
7:0	Reserved	R/W	0110 0111h	Reserved. Always write 0110 0111 to these bits.

7.6.3.39 Register 38: Reserved (address = 26h) [reset = 0101 1101], Page 1
Figure 157. Register 38

7	6	5	4	3	2	1	0
0	1	0	1	1	1	0	1
R/W-0h	R/W-1h	R/W-0h	R/W-1h	R/W-1h	R/W-1h	R/W-0h	R/W-1h

Table 135. Register 38 Field Descriptions

Bit	Field	Type	Reset	Description
7:0	Reserved	R/W	0101 1101h	Reserved. Always write 0101 1101 to these bits.

7.6.3.40 Register 39: Reserved (address = 27h) [reset = 0111 1101], Page 1
Figure 158. Register 39

7	6	5	4	3	2	1	0
0	1	1	1	1	1	0	1
R/W-0h	R/W-1h	R/W-1h	R/W-1h	R/W-1h	R/W-1h	R/W-0h	R/W-1h

Table 136. Register 39 Field Descriptions

Bit	Field	Type	Reset	Description
7:0	Reserved	R/W	0111 1101h	Reserved. Always write 0111 1101 to these bits.

7.6.3.41 Register 40: Reserved (address = 28h) [reset = 1000 0011], Page 1
Figure 159. Register 40

7	6	5	4	3	2	1	0
1	0	0	0	0	0	1	1
R/W-1h	R/W-0h	R/W-0h	R/W-0h	R/W-0h	R/W-0h	R/W-1h	R/W-1h

Table 137. Register 40 Field Descriptions

Bit	Field	Type	Reset	Description
7:0	Reserved	R/W	1000 0011h	Reserved. Always write 1000 0011 to these bits.

7.6.3.42 Register 41: Reserved (address = 29h) [reset = 1000 0100], Page 1
Figure 160. Register 41

7	6	5	4	3	2	1	0
1	0	0	0	0	1	0	0
R/W-1h	R/W-0h	R/W-0h	R/W-0h	R/W-0h	R/W-1h	R/W-0h	R/W-0h

Table 138. Register 41 Field Descriptions

Bit	Field	Type	Reset	Description
7:0	Reserved	R/W	1000 0100h	Reserved. Always write 1000 0100 to these bits.

7.6.3.43 Register 42: Reserved (address = 2Ah) [reset = 1110 1110], Page 1
Figure 161. Register 42

7	6	5	4	3	2	1	0
1	1	1	0	1	1	1	0
R/W-1h	R/W-1h	R/W-1h	R/W-0h	R/W-1h	R/W-1h	R/W-1h	R/W-0h

Table 139. Register 42 Field Descriptions

Bit	Field	Type	Reset	Description
7:0	Reserved	R/W	1110 1110h	Reserved. Always write 1110 1110 to these bits.

7.6.3.44 Register 43: Reserved (address = 2Bh) [reset = 0111 1101], Page 1
Figure 162. Register 43

7	6	5	4	3	2	1	0
0	1	1	1	1	1	0	1
R/W-0h	R/W-1h	R/W-1h	R/W-1h	R/W-1h	R/W-1h	R/W-0h	R/W-1h

Table 140. Register 43 Field Descriptions

Bit	Field	Type	Reset	Description
7:0	Reserved	R/W	0111 1101h	Reserved. Always write 0111 1101 to these bits.

7.6.3.45 Register 44: Reserved (address = 2Ch) [reset = 1000 0011], Page 1
Figure 163. Register 44

7	6	5	4	3	2	1	0
1	0	0	0	0	0	1	1
R/W-1h	R/W-0h	R/W-0h	R/W-0h	R/W-0h	R/W-0h	R/W-1h	R/W-1h

Table 141. Register 44 Field Descriptions

Bit	Field	Type	Reset	Description
7:0	Reserved	R/W	1000 0011h	Reserved. Always write 1000 0011 to these bits.

7.6.3.46 Register 45: Reserved (address = 2Dh) [reset = 1000 0100], Page 1
Figure 164. Register 45

7	6	5	4	3	2	1	0
1	0	0	0	0	1	0	0
R/W-1h	R/W-0h	R/W-0h	R/W-0h	R/W-0h	R/W-1h	R/W-0h	R/W-0h

Table 142. Register 45 Field Descriptions

Bit	Field	Type	Reset	Description
7:0	Reserved	R/W	1000 0100h	Reserved. Always write 1000 0100 to these bits.

7.6.3.47 Register 46: Reserved (address = 2Eh) [reset = 1110 1110], Page 1
Figure 165. Register 46

7	6	5	4	3	2	1	0
1	1	1	0	1	1	1	0
R/W-1h	R/W-1h	R/W-1h	R/W-0h	R/W-1h	R/W-1h	R/W-1h	R/W-0h

Table 143. Register 46 Field Descriptions

Bit	Field	Type	Reset	Description
7:0	Reserved	R/W	1110 1110h	Reserved. Always write 1110 1110 to these bits.

7.6.3.48 Register 47: Reserved (address = 2Fh) [reset = 0011 1001], Page 1
Figure 166. Register 47

7	6	5	4	3	2	1	0
0	0	1	1	1	0	0	1
R/W-0h	R/W-0h	R/W-1h	R/W-1h	R/W-1h	R/W-0h	R/W-0h	R/W-1h

Table 144. Register 47 Field Descriptions

Bit	Field	Type	Reset	Description
7:0	Reserved	R/W	0011 1001h	Reserved. Always write 0011 1001 to these bits.

7.6.3.49 Register 48: Reserved (address = 30h) [reset = 0101 0101], Page 1
Figure 167. Register 48

7	6	5	4	3	2	1	0
0	1	0	1	0	1	0	1
R/W-0h	R/W-1h	R/W-0h	R/W-1h	R/W-0h	R/W-1h	R/W-0h	R/W-1h

Table 145. Register 48 Field Descriptions

Bit	Field	Type	Reset	Description
7:0	Reserved	R/W	0101 0101h	Reserved. Always write 0101 0101 to these bits.

7.6.3.50 Register 49: Reserved (address = 31h) [reset = 1111 0011], Page 1
Figure 168. Register 49

7	6	5	4	3	2	1	0
1	1	1	1	0	0	1	1
R/W-1h	R/W-1h	R/W-1h	R/W-1h	R/W-0h	R/W-0h	R/W-1h	R/W-1h

Table 146. Register 49 Field Descriptions

Bit	Field	Type	Reset	Description
7:0	Reserved	R/W	1111 0011h	Reserved. Always write 1111 0011 to these bits.

7.6.3.51 Register 50: Reserved (address = 32h) [reset = 0010 1101], Page 1
Figure 169. Register 50

7	6	5	4	3	2	1	0
0	0	1	0	1	1	0	1
R/W-0h	R/W-0h	R/W-1h	R/W-0h	R/W-1h	R/W-1h	R/W-0h	R/W-1h

Table 147. Register 50 Field Descriptions

Bit	Field	Type	Reset	Description
7:0	Reserved	R/W	0010 1101h	Reserved. Always write 0010 1101 to these bits.

7.6.3.52 Register 51: Reserved (address = 33h) [reset = 0101 0011], Page 1
Figure 170. Register 51

7	6	5	4	3	2	1	0
0	1	0	1	0	0	1	1
R/W-0h	R/W-1h	R/W-0h	R/W-1h	R/W-0h	R/W-0h	R/W-1h	R/W-1h

Table 148. Register 51 Field Descriptions

Bit	Field	Type	Reset	Description
7:0	Reserved	R/W	0101 0011h	Reserved. Always write 0101 0011 to these bits.

7.6.3.53 Register 52: Reserved (address = 34h) [reset = 0111 1110], Page 1
Figure 171. Register 52

7	6	5	4	3	2	1	0
0	1	1	1	1	1	1	0
R/W-0h	R/W-1h	R/W-1h	R/W-1h	R/W-1h	R/W-1h	R/W-1h	R/W-0h

Table 149. Register 52 Field Descriptions

Bit	Field	Type	Reset	Description
7:0	Reserved	R/W	0111 1110h	Reserved. Always write 0111 1110 to these bits.

7.6.3.54 Register 53: Reserved (address = 35h) [reset = 0111 1111], Page 1
Figure 172. Register 53

7	6	5	4	3	2	1	0
0	1	1	1	1	1	1	1
R/W-0h	R/W-1h	R/W-1h	R/W-1h	R/W-1h	R/W-1h	R/W-1h	R/W-1h

Table 150. Register 53 Field Descriptions

Bit	Field	Type	Reset	Description
7:0	Reserved	R/W	0111 1111h	Reserved. Always write 0111 1111 to these bits.

7.6.3.55 Register 54: Reserved (address = 36h) [reset = 1111 1111], Page 1
Figure 173. Register 54

7	6	5	4	3	2	1	0
1	1	1	1	1	1	1	1
R/W-1h	R/W-1h	R/W-1h	R/W-1h	R/W-1h	R/W-1h	R/W-1h	R/W-1h

Table 151. Register 54 Field Descriptions

Bit	Field	Type	Reset	Description
7:0	Reserved	R/W	1h	Reserved. Always write ones to these bits.

7.6.3.56 Registers 55–64: Reserved (address = 37h–40h) [reset = 0000 0000], Page 1
Figure 174. Registers 55–64

7	6	5	4	3	2	1	0
0	0	0	0	0	0	0	0
R/W-0h	R/W-0h	R/W-0h	R/W-0h	R/W-0h	R/W-0h	R/W-0h	R/W-0h

Table 152. Registers 55–64 Field Descriptions

Bit	Field	Type	Reset	Description
7:0	Reserved	R/W	0h	Reserved. Always write zeros to these bits.

7.6.3.57 Register 65: ADC High-Pass Filter N0 Coefficient MSB Register (address = 41h) [reset = 0011 1001], Page 1
Figure 175. Register 65

7	6	5	4	3	2	1	0
ADC High-Pass Filter N0 Coefficient MSB							
R/W-0h	R/W-0h	R/W-1h	R/W-1h	R/W-1h	R/W-0h	R/W-0h	R/W-1h

Table 153. Register 65 Field Descriptions

Bit	Field	Type	Reset	Description
7:0	ADC High-Pass Filter N0 Coefficient MSB	R/W	0011 1001h	ADC high-pass filter N0 coefficient MSB. The 16-bit integer contained in the MSB and LSB registers for this coefficient are interpreted as a 2's-complement integer with possible values ranging from –32,768 to 32,767.

7.6.3.58 Register 66: ADC High-Pass Filter N0 Coefficient LSB Register (address = 42h) [reset = 1110 1010], Page 1
Figure 176. Register 66

7	6	5	4	3	2	1	0
Channel ADC High-Pass Filter N0 Coefficient LSB							
R/W-1h	R/W-1h	R/W-1h	R/W-0h	R/W-1h	R/W-0h	R/W-1h	R/W-0h

Table 154. Register 66 Field Descriptions

Bit	Field	Type	Reset	Description
7:0	Channel ADC High-Pass Filter N0 Coefficient LSB	R/W	1110 1010h	Channel ADC high-pass filter N0 coefficient LSB. The 16-bit integer contained in the MSB and LSB registers for this coefficient are interpreted as a 2's-complement integer with possible values ranging from –32,768 to 32,767.

7.6.3.59 Register 67: Channel ADC High-Pass Filter N1 Coefficient MSB Register (address = 43h) [reset = 1000 0000, Page 1
Figure 177. Register 67

7	6	5	4	3	2	1	0
Channel ADC High-Pass Filter N1 Coefficient MSB							
R/W-1h	R/W-0h	R/W-0h	R/W-0h	R/W-0h	R/W-0h	R/W-0h	R/W-0h

Table 155. Register 67 Field Descriptions

Bit	Field	Type	Reset	Description
7:0	Channel ADC High-Pass Filter N1 Coefficient MSB	R/W	1000 0000h	Channel ADC high-pass filter N1 coefficient MSB. The 16-bit integer contained in the MSB and LSB registers for this coefficient are interpreted as a 2's-complement integer with possible values ranging from –32,768 to 32,767.

7.6.3.60 Register 68: Channel ADC High-Pass Filter N1 Coefficient LSB Register (address = 44h) [reset = 0001 0110], Page 1
Figure 178. Register 68

7	6	5	4	3	2	1	0
Channel ADC High-Pass Filter N1 Coefficient LSB							
R/W-0h	R/W-0h	R/W-0h	R/W-1h	R/W-0h	R/W-1h	R/W-1h	R/W-0h

Table 156. Register 68 Field Descriptions

Bit	Field	Type	Reset	Description
7:0	Channel ADC High-Pass Filter N1 Coefficient LSB	R/W	0001 0110h	Channel ADC high-pass filter N1 coefficient LSB. The 16-bit integer contained in the MSB and LSB registers for this coefficient are interpreted as a 2's-complement integer with possible values ranging from –32,768 to 32,767.

7.6.3.61 Register 69: Channel ADC High-Pass Filter D1 Coefficient MSB Register (address = 45h) [reset = 0111 1111], Page 1
Figure 179. Register 69

7	6	5	4	3	2	1	0
Channel ADC High-Pass Filter D1 Coefficient MSB							
R/W-0h	R/W-1h	R/W-1h	R/W-1h	R/W-1h	R/W-1h	R/W-1h	R/W-1h

Table 157. Register 69 Field Descriptions

Bit	Field	Type	Reset	Description
7:0	Channel ADC High-Pass Filter D1 Coefficient MSB	R/W	0111 1111h	Channel ADC high-pass filter D1 coefficient MSB. The 16-bit integer contained in the MSB and LSB registers for this coefficient are interpreted as a 2's-complement integer with possible values ranging from –32,768 to 32,767.

7.6.3.62 Register 70: Channel ADC High-Pass Filter D1 Coefficient LSB Register (address = 46h) [reset = 1101 0101], Page 1

Figure 180. Register 70

7	6	5	4	3	2	1	0
Channel ADC High-Pass Filter D1 Coefficient LSB							
R/W-1h	R/W-1h	R/W-0h	R/W-1h	R/W-0h	R/W-1h	R/W-0h	R/W-1h

Table 158. Register 70 Field Descriptions

Bit	Field	Type	Reset	Description
7:0	Channel ADC High-Pass Filter D1 Coefficient LSB	R/W	1101 0101h	Channel ADC high-pass filter D1 coefficient LSB. The 16-bit integer contained in the MSB and LSB registers for this coefficient are interpreted as a 2's-complement integer with possible values ranging from -32,768 to 32,767.

7.6.3.63 Register 71: Reserved (address = 47h) [reset = 0111 1111], Page 1

Figure 181. Register 71

7	6	5	4	3	2	1	0
0	1	1	1	1	1	1	1
R/W-0h	R/W-1h	R/W-1h	R/W-1h	R/W-1h	R/W-1h	R/W-1h	R/W-1h

Table 159. Register 71 Field Descriptions

Bit	Field	Type	Reset	Description
7:0	Reserved	R/W	0111 1111h	Reserved. Always write 0111 1111 to these bits.

7.6.3.64 Register 72: Reserved (address = 48h) [reset = 1110 1010], Page 1

Figure 182. Register 72

7	6	5	4	3	2	1	0
1	1	1	0	1	0	1	0
R/W-1h	R/W-1h	R/W-1h	R/W-0h	R/W-1h	R/W-0h	R/W-1h	R/W-0h

Table 160. Register 72 Field Descriptions

Bit	Field	Type	Reset	Description
7:0	Reserved	R/W	1110 1010h	Reserved. Always write 1110 1010 to these bits.

7.6.3.65 Register 73: Reserved (address = 49h) [reset = 1000 0000], Page 1

Figure 183. Register 73

7	6	5	4	3	2	1	0
1	0	0	0	0	0	0	0
R/W-1h	R/W-0h	R/W-0h	R/W-0h	R/W-0h	R/W-0h	R/W-0h	R/W-0h

Table 161. Register 73 Field Descriptions

Bit	Field	Type	Reset	Description
7:0	Reserved	R/W	1000 0000h	Reserved. Always write 1000 0000 to these bits.

7.6.3.66 Register 74: Reserved (address = 4Ah) [reset = 0001 0110], Page 1
Figure 184. Register 74

7	6	5	4	3	2	1	0
0	0	0	1	0	1	1	0
R/W-0h	R/W-0h	R/W-0h	R/W-1h	R/W-0h	R/W-1h	R/W-1h	R/W-0h

Table 162. Register 74 Field Descriptions

Bit	Field	Type	Reset	Description
7:0	Reserved	R/W	0001 0110h	Reserved. Always write 0001 0110 to these bits.

7.6.3.67 Register 75: Reserved (address = 4Bh) [reset = 0111 1111], Page 1
Figure 185. Register 75

7	6	5	4	3	2	1	0
0	1	1	1	1	1	1	1
R/W-0h	R/W-1h	R/W-1h	R/W-1h	R/W-1h	R/W-1h	R/W-1h	R/W-1h

Table 163. Register 75 Field Descriptions

Bit	Field	Type	Reset	Description
7:0	Reserved	R/W	0111 1111h	Reserved. Always write 0111 1111 to these bits.

7.6.3.68 Register 76: Reserved (address = 4Ch) [reset = 1101 0101], Page 1
Figure 186. Register 76

7	6	5	4	3	2	1	0
1	1	0	1	0	1	0	1
R/W-1h	R/W-1h	R/W-0h	R/W-1h	R/W-0h	R/W-1h	R/W-0h	R/W-1h

Table 164. Register 76 Field Descriptions

Bit	Field	Type	Reset	Description
7:0	Reserved	R/W	1101 0101h	Reserved. Always write 1101 0101 to these bits.

7.6.3.69 Registers 77h–127h: Reserved (address = 4Dh) [reset = 0000 0000], Page 1
Figure 187. Registers 77h–127h

7	6	5	4	3	2	1	0
0	0	0	0	0	0	0	0
R-0h	R-0h	R-0h	R-0h	R-0h	R-0h	R-0h	R-0h

Table 165. Registers 77h–127h Field Descriptions

Bit	Field	Type	Reset	Description
7-0	Reserved	R	0h	Reserved. Always write zeros to these bits.

8 Application and Implementation

NOTE

Information in the following applications sections is not part of the TI component specification, and TI does not warrant its accuracy or completeness. TI's customers are responsible for determining suitability of components for their purposes. Customers should validate and test their design implementation to confirm system functionality.

8.1 Application Information

The TLV320AIC3109-Q1 is a highly integrated low-power mono audio codec with integrated headphone and line amplifiers. All features of the TLV320AIC3109-Q1 are accessed by programmable registers. An external processor with I²C protocol is required to control the device. Good practice is to perform a hardware reset after initial power-up to ensure that all registers are in default states. Extensive register-based power control is included, enabling mono 48-kHz DAC playback as low as 14-mW from a 3.3-V analog supply, making the device ideal for portable battery-powered audio applications.

8.2 Typical Application

Governing bodies around the world have implemented specific legislation to require automotive companies to install emergency call (E-Call) systems in order to reduce emergency response times and thereby save lives. E-Call systems are activated during a collision or emergency situation and automatically facilitate a call to emergency services. The state of a vehicle after a collision is difficult to predict and can include a disconnected battery, trapped passengers, and a noisy environment. For this reason, the E-Call module must have its own battery power source and be able to sustain a hands-free call for at least ten minutes (depending on specific regional legislation). The TLV320AIC3109-Q1 as an audio codec and the [TAS5411-Q1](#) as an audio amplifier are optimal choices for an E-Call application because these devices offers low power consumption and still allow a loud and clear conversation with an emergency operator.

Typical Application (continued)

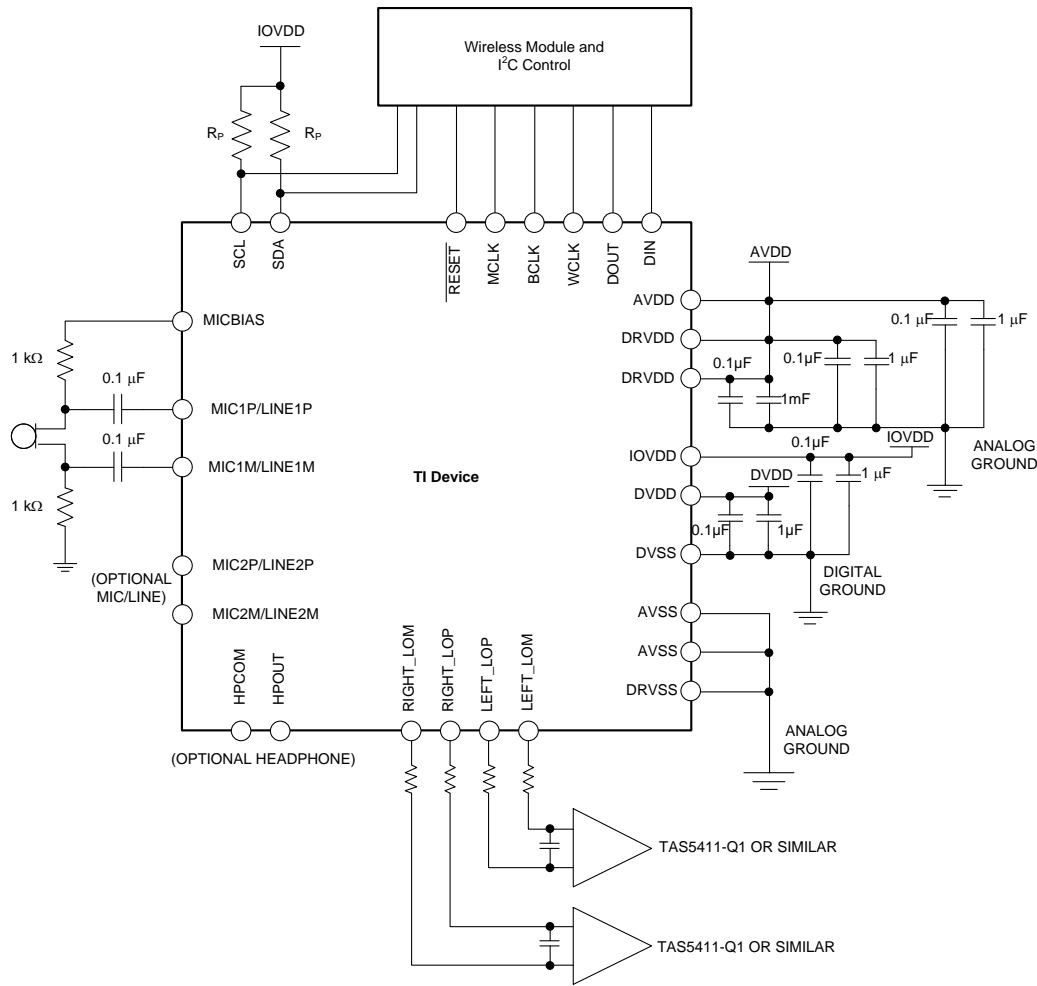

Copyright © 2017, Texas Instruments Incorporated

Figure 188. Typical Connections for Emergency Call System (E-Call)

8.2.1 Design Requirements

Table 166 shows the parameters used for this application.

Table 166. Design Parameters

PARAMETER	VALUE
AVDD, DRVDD	3.3 V
IOVDD, DVDD	1.8 V
MCLK frequency	12.288 MHz
BCLK frequency	3.072 MHz
WCLK frequency (sample rate)	48 KHz
Current consumption (AVDD + DRVDD)	4.31 mA
Current consumption (DVDD + IOVDD)	2.45 mA
Total power consumption	20 mW

8.2.2 Detailed Design Procedure

The audio codec in an E-Call system must be able to support full duplex communication between the digital audio source from the wireless module, the microphone input, and the speaker output. The TLV320AIC3109-Q1 is a mono audio codec that meets the low power requirements and has all the features necessary for an E-Call application.

The wireless module communicates to the audio codec through I²S interface. The class-D amplifier must maintain sufficient output power to drive the speaker to the specified audio level with sufficient audio quality. The amplifier must also have high efficiency to optimize power consumption and good EMI, EMC performance. In addition, many E-Call systems require speaker diagnostics and device protection circuitry.

The TLV320AIC3109-Q1 is a low-power mono audio codec that integrates a mono preamplifier and offers multiple inputs and outputs that are programmable in single-ended or fully differential configurations. The TLV320AIC3109-Q1 flexible configuration allows certain internal blocks to be enabled or bypassed. This flexibility allows for optimal power consumption, which is very important for E-Call systems.

The TAS5411-Q1 is a mono digital class-D audio amplifier ideal for use in automotive emergency call, telematics, instrument cluster, and infotainment applications. The device provides up to 8 W into 4 Ω at less than 10% THD+N from a 14.4-Vdc automotive battery. The wide operating voltage range and excellent efficiency make the device ideal for start-stop support or running from a backup battery when required. The integrated load-dump protection reduces external voltage clamp cost and size, and the onboard load diagnostics report the status of the speaker through I²C interface.

Following the recommended component placement (see the schematic layout and routing provided in the [Layout](#) section), integrate the TLV320AIC3109-Q1 and supporting components into the system PCB design.

Determining sample rate and master clock frequency is required because all internal timing are derived from the master clock during power-up. See the [Audio Clock Generation](#) section for more information on how to configure the required clocks for the device.

When powered up, the device has several features powered down because the audio codec device is designed for low-power applications. Correct routing of the signals internal to the TLV320AIC3109-Q1 is achieved by correctly setting the device registers, powering up the required stages of the device, and configuring the internal switches for desired performance.

8.2.3 Application Curves

As shown in [Figure 189](#), the TAS5411-Q1 can reach up to 83% into a 4-Ω load. Output power can be up to 8 W at 10% THD+N into a 4-Ω load.

The TLV320AIC3109-Q1 features a configurable MICBIAS level (that is, 2 V, 2.5 V, or AVDD). As shown in [Figure 190](#), 2-V and 2.5-V MICBIAS levels remain stable with changes in the AVDD supply voltage. When the MICBIAS output voltage is configured as AVDD, the MICBIAS output voltage follows AVDD.

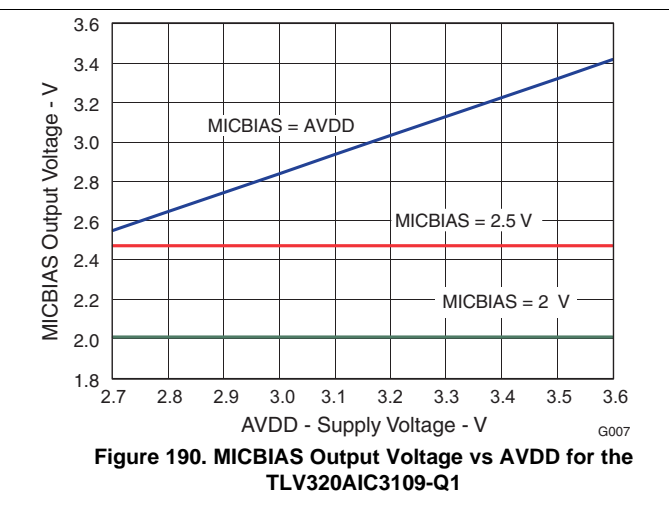
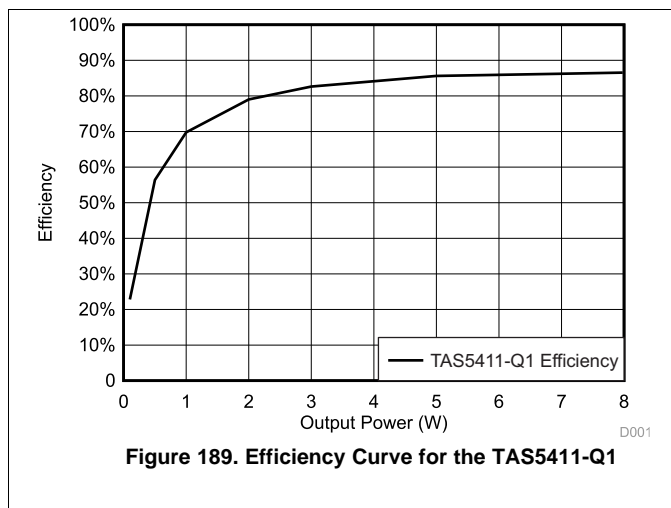

9 Power Supply Recommendations

The TLV320AIC3109-Q1 is designed to be extremely tolerant of power-supply sequencing. However, in some rare instances, unexpected conditions can be attributed to power-supply sequencing. The following sequence provides the most robust operation.

Power-up IOVDD first. Power-up the analog supplies, which includes AVDD and DRVDD, second. Power-up the digital supply DVDD last. Keep $\overline{\text{RESET}}$ low until all supplies are stable. The analog supplies must be greater than or equal to DVDD at all times. Figure 191 and Table 167 detail the preferred power-supply sequence.

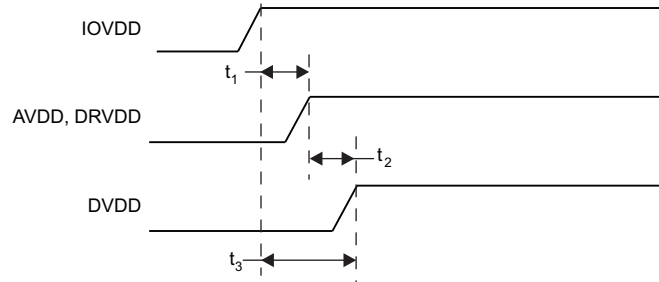

Figure 191. TLV320AIC3109-Q1 Power-Supply Sequencing

Table 167. TLV320AIC3109-Q1 Power-Supply Sequencing

		MIN	MAX	UNIT
t_1	IOVDD to AVDD, DRVDD	0		ms
t_2	AVDD to DVDD	0	5	ms
t_3	IOVDD, to DVDD	0		ms

10 Layout

10.1 Layout Guidelines

Printed circuit board (PCB) design is made considering the application, and the review is specific for each system requirements. However, general considerations can optimize the system performance:

- Connect the TLV320AIC3109-Q1 thermal pad to the analog output driver ground
- Separate the analog and digital grounds to prevent possible digital noise from affecting the analog performance of the board
- The TLV320AIC3109-Q1 requires the decoupling capacitors to be placed as close as possible to the device power-supply terminals
- If possible, route the differential audio signals differentially on the PCB to obtain better noise immunity

10.2 Layout Example

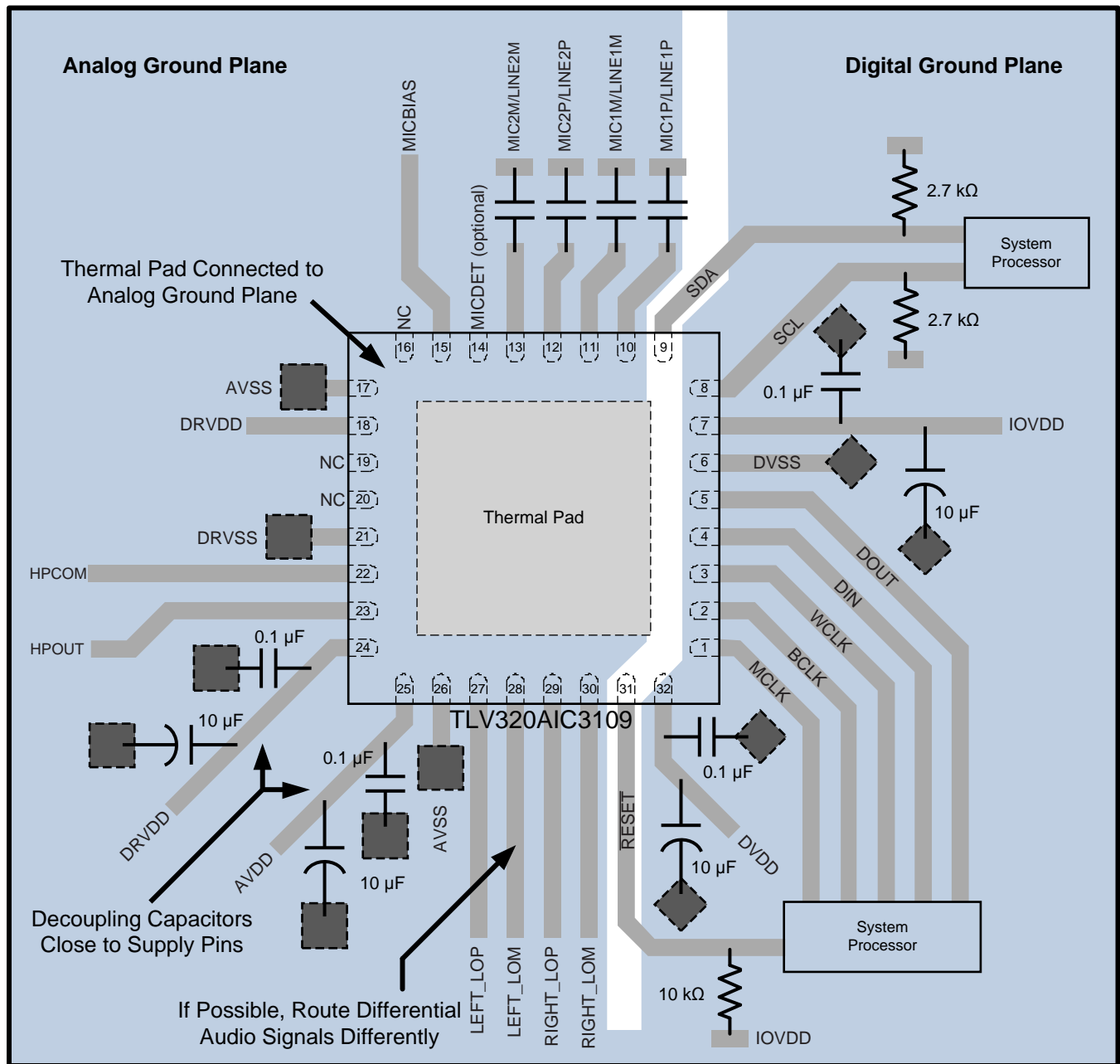

Figure 192. Layout Example

11 Device and Documentation Support

11.1 Documentation Support

11.1.1 Related Documentation

For related documentation see the following:

[TAS5411-Q1 8-W Mono Automotive Class-D Audio Amplifier With Load Dump and I²C Diagnostics](#)

11.2 Receiving Notification of Documentation Updates

To receive notification of documentation updates, navigate to the device product folder on ti.com. In the upper right corner, click on *Alert me* to register and receive a weekly digest of any product information that has changed. For change details, review the revision history included in any revised document.

11.3 Community Resources

The following links connect to TI community resources. Linked contents are provided "AS IS" by the respective contributors. They do not constitute TI specifications and do not necessarily reflect TI's views; see TI's [Terms of Use](#).

TI E2E™ Online Community *TI's Engineer-to-Engineer (E2E) Community*. Created to foster collaboration among engineers. At e2e.ti.com, you can ask questions, share knowledge, explore ideas and help solve problems with fellow engineers.

Design Support *TI's Design Support* Quickly find helpful E2E forums along with design support tools and contact information for technical support.

11.4 Trademarks

E2E is a trademark of Texas Instruments.

All other trademarks are the property of their respective owners.

11.5 Electrostatic Discharge Caution



This integrated circuit can be damaged by ESD. Texas Instruments recommends that all integrated circuits be handled with appropriate precautions. Failure to observe proper handling and installation procedures can cause damage.

ESD damage can range from subtle performance degradation to complete device failure. Precision integrated circuits may be more susceptible to damage because very small parametric changes could cause the device not to meet its published specifications.

11.6 Glossary

[SLYZ022](#) — *TI Glossary*.

This glossary lists and explains terms, acronyms, and definitions.

12 Mechanical, Packaging, and Orderable Information

The following pages include mechanical, packaging, and orderable information. This information is the most current data available for the designated devices. This data is subject to change without notice and revision of this document. For browser-based versions of this data sheet, refer to the left-hand navigation.

PACKAGING INFORMATION

Orderable Device	Status (1)	Package Type	Package Drawing	Pins	Package Qty	Eco Plan (2)	Lead/Ball Finish (6)	MSL Peak Temp (3)	Op Temp (°C)	Device Marking (4/5)	Samples
6PAIC3109TRHBRQ1	ACTIVE	VQFN	RHB	32	3000	Green (RoHS & no Sb/Br)	CU NIPDAU	Level-3-260C-168 HR	-40 to 105	3109T	Samples
6PAIC3109TWRHMRQ1	PREVIEW	VQFN	RHM	32	3000	Green (RoHS & no Sb/Br)	CU NIPDAUAG	Level-3-260C-168 HR	-40 to 105	3109TW	

(1) The marketing status values are defined as follows:

ACTIVE: Product device recommended for new designs.

LIFEBUY: TI has announced that the device will be discontinued, and a lifetime-buy period is in effect.

NRND: Not recommended for new designs. Device is in production to support existing customers, but TI does not recommend using this part in a new design.

PREVIEW: Device has been announced but is not in production. Samples may or may not be available.

OBSOLETE: TI has discontinued the production of the device.

(2) **RoHS:** TI defines "RoHS" to mean semiconductor products that are compliant with the current EU RoHS requirements for all 10 RoHS substances, including the requirement that RoHS substance do not exceed 0.1% by weight in homogeneous materials. Where designed to be soldered at high temperatures, "RoHS" products are suitable for use in specified lead-free processes. TI may reference these types of products as "Pb-Free".

RoHS Exempt: TI defines "RoHS Exempt" to mean products that contain lead but are compliant with EU RoHS pursuant to a specific EU RoHS exemption.

Green: TI defines "Green" to mean the content of Chlorine (Cl) and Bromine (Br) based flame retardants meet JS709B low halogen requirements of <=1000ppm threshold. Antimony trioxide based flame retardants must also meet the <=1000ppm threshold requirement.

(3) MSL, Peak Temp. - The Moisture Sensitivity Level rating according to the JEDEC industry standard classifications, and peak solder temperature.

(4) There may be additional marking, which relates to the logo, the lot trace code information, or the environmental category on the device.

(5) Multiple Device Markings will be inside parentheses. Only one Device Marking contained in parentheses and separated by a "-" will appear on a device. If a line is indented then it is a continuation of the previous line and the two combined represent the entire Device Marking for that device.

(6) Lead/Ball Finish - Orderable Devices may have multiple material finish options. Finish options are separated by a vertical ruled line. Lead/Ball Finish values may wrap to two lines if the finish value exceeds the maximum column width.

Important Information and Disclaimer:The information provided on this page represents TI's knowledge and belief as of the date that it is provided. TI bases its knowledge and belief on information provided by third parties, and makes no representation or warranty as to the accuracy of such information. Efforts are underway to better integrate information from third parties. TI has taken and continues to take reasonable steps to provide representative and accurate information but may not have conducted destructive testing or chemical analysis on incoming materials and chemicals. TI and TI suppliers consider certain information to be proprietary, and thus CAS numbers and other limited information may not be available for release.

In no event shall TI's liability arising out of such information exceed the total purchase price of the TI part(s) at issue in this document sold by TI to Customer on an annual basis.

TAPE AND REEL INFORMATION



QUADRANT ASSIGNMENTS FOR PIN 1 ORIENTATION IN TAPE



*All dimensions are nominal

Device	Package Type	Package Drawing	Pins	SPQ	Reel Diameter (mm)	Reel Width W1 (mm)	A0 (mm)	B0 (mm)	K0 (mm)	P1 (mm)	W (mm)	Pin1 Quadrant
6PAIC3109TRHBRQ1	VQFN	RHB	32	3000	330.0	12.4	5.3	5.3	1.5	8.0	12.0	Q2

TAPE AND REEL BOX DIMENSIONS

*All dimensions are nominal

Device	Package Type	Package Drawing	Pins	SPQ	Length (mm)	Width (mm)	Height (mm)
6PAIC3109TRHBRQ1	VQFN	RHB	32	3000	367.0	367.0	35.0

GENERIC PACKAGE VIEW

RHM 32

VQFNP - 0.9 mm max height

PLASTIC QUAD FLATPACK - NO LEAD

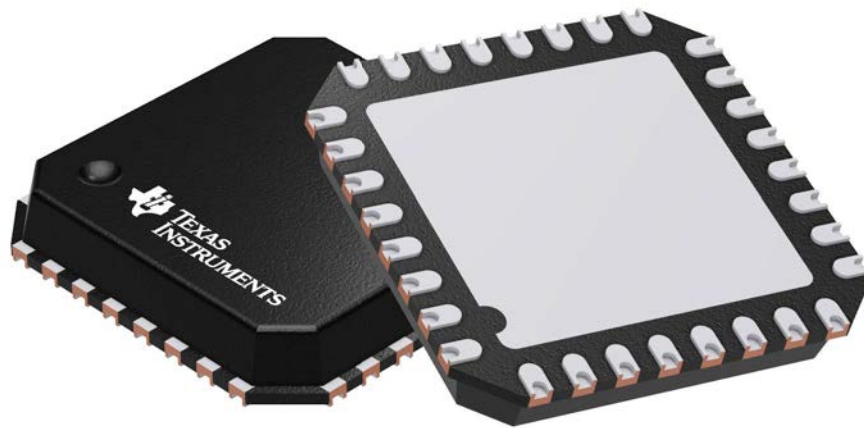

Images above are just a representation of the package family, actual package may vary.
Refer to the product data sheet for package details.

4205347/C

RHM0032A

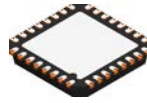

PACKAGE OUTLINE

VQFNP - 0.9 mm max height

PLASTIC QUAD FLATPACK - NO LEAD

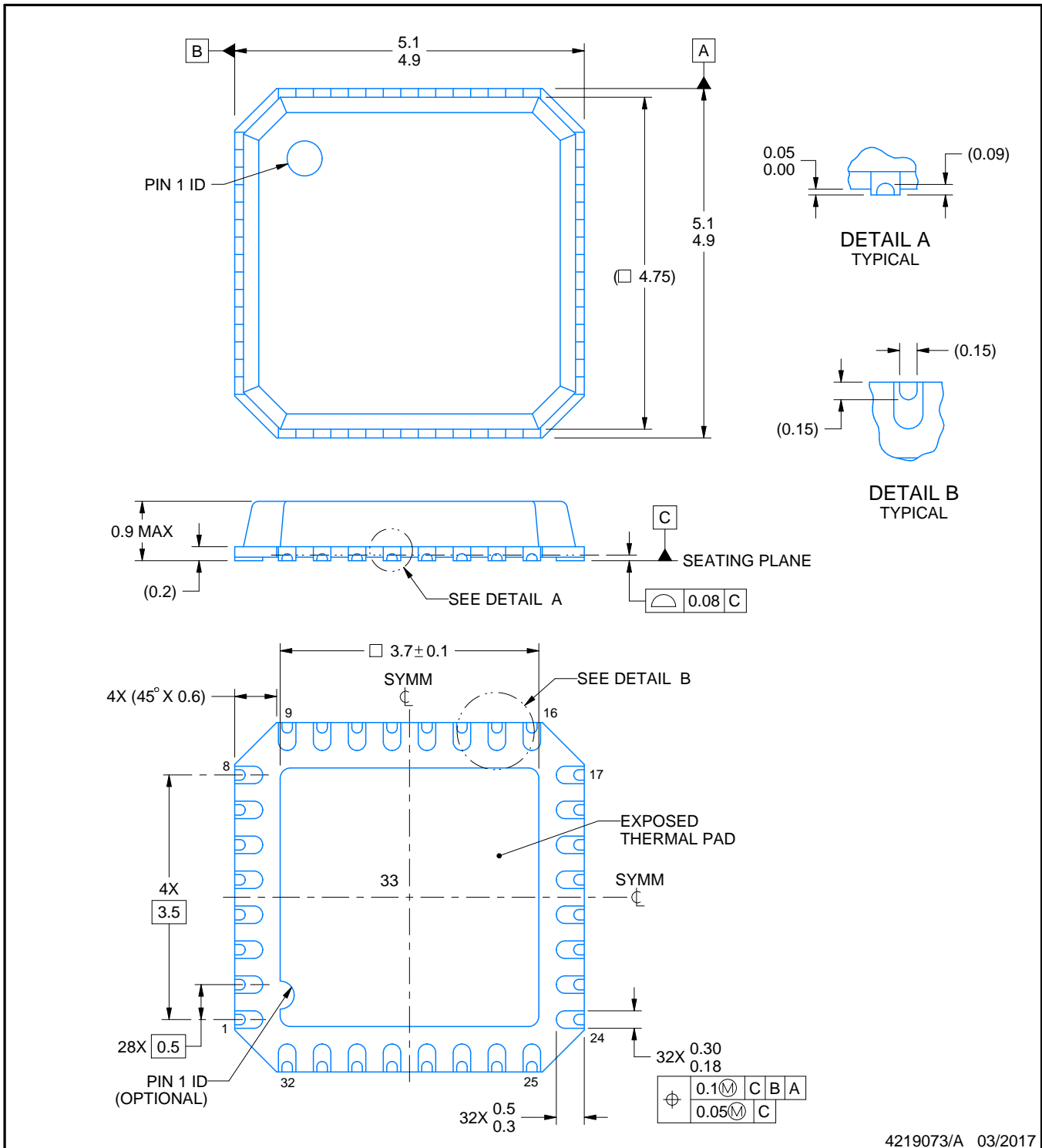

4219073/A 03/2017

NOTES:

1. All linear dimensions are in millimeters. Any dimensions in parenthesis are for reference only. Dimensioning and tolerancing per ASME Y14.5M.
2. This drawing is subject to change without notice.
3. The package thermal pad must be soldered to the printed circuit board for thermal and mechanical performance.

EXAMPLE BOARD LAYOUT

RHM0032A

VQFNP - 0.9 mm max height

PLASTIC QUAD FLATPACK - NO LEAD

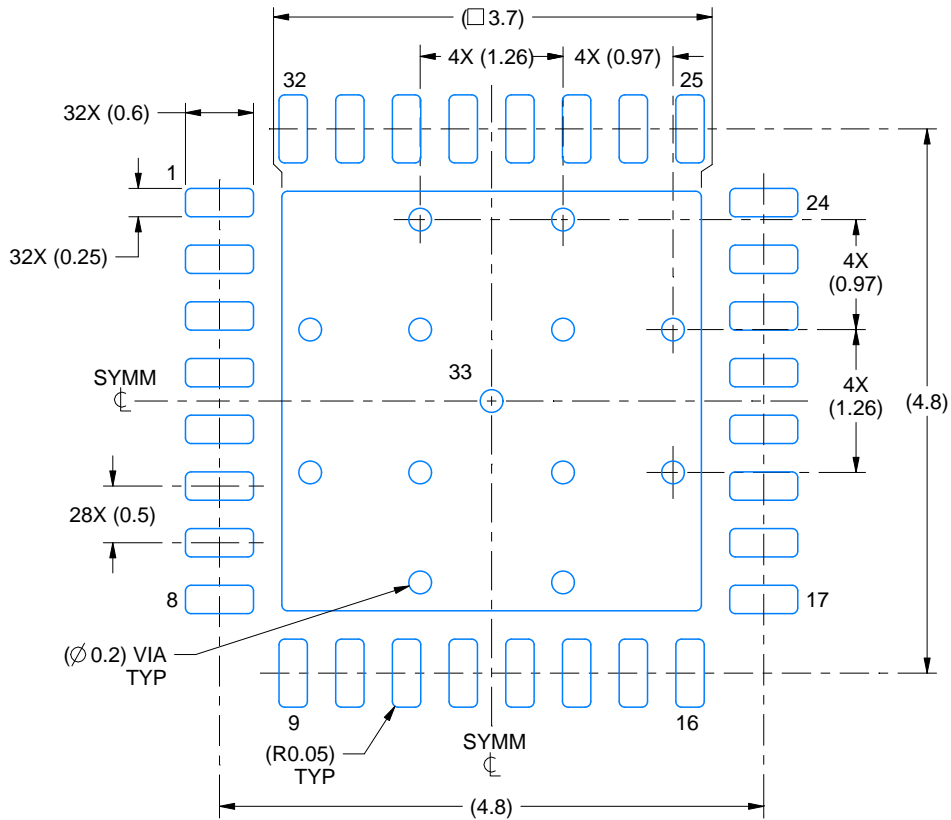

LAND PATTERN EXAMPLE
EXPOSED METAL SHOWN
SCALE:15X

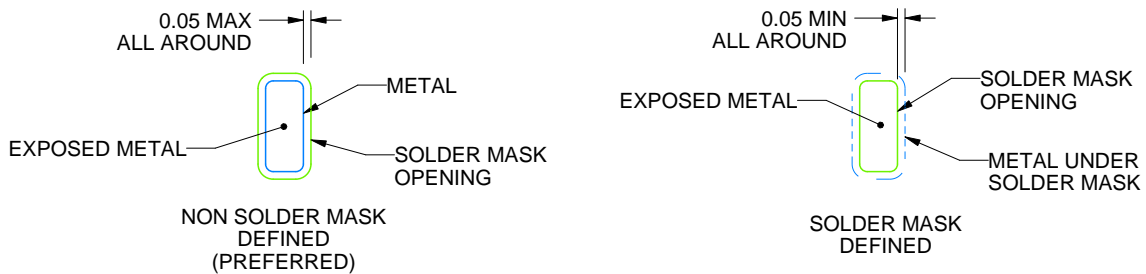

SOLDER MASK DETAILS

4219073/A 03/2017

NOTES: (continued)

4. This package is designed to be soldered to a thermal pad on the board. For more information, see Texas Instruments literature number SLUA271 (www.ti.com/lit/slua271).
5. Vias are optional depending on application, refer to device data sheet. If any vias are implemented, refer to their locations shown on this view. It is recommended that vias under paste be filled, plugged or tented.

EXAMPLE STENCIL DESIGN

RHM0032A

VQFNP - 0.9 mm max height

PLASTIC QUAD FLATPACK - NO LEAD

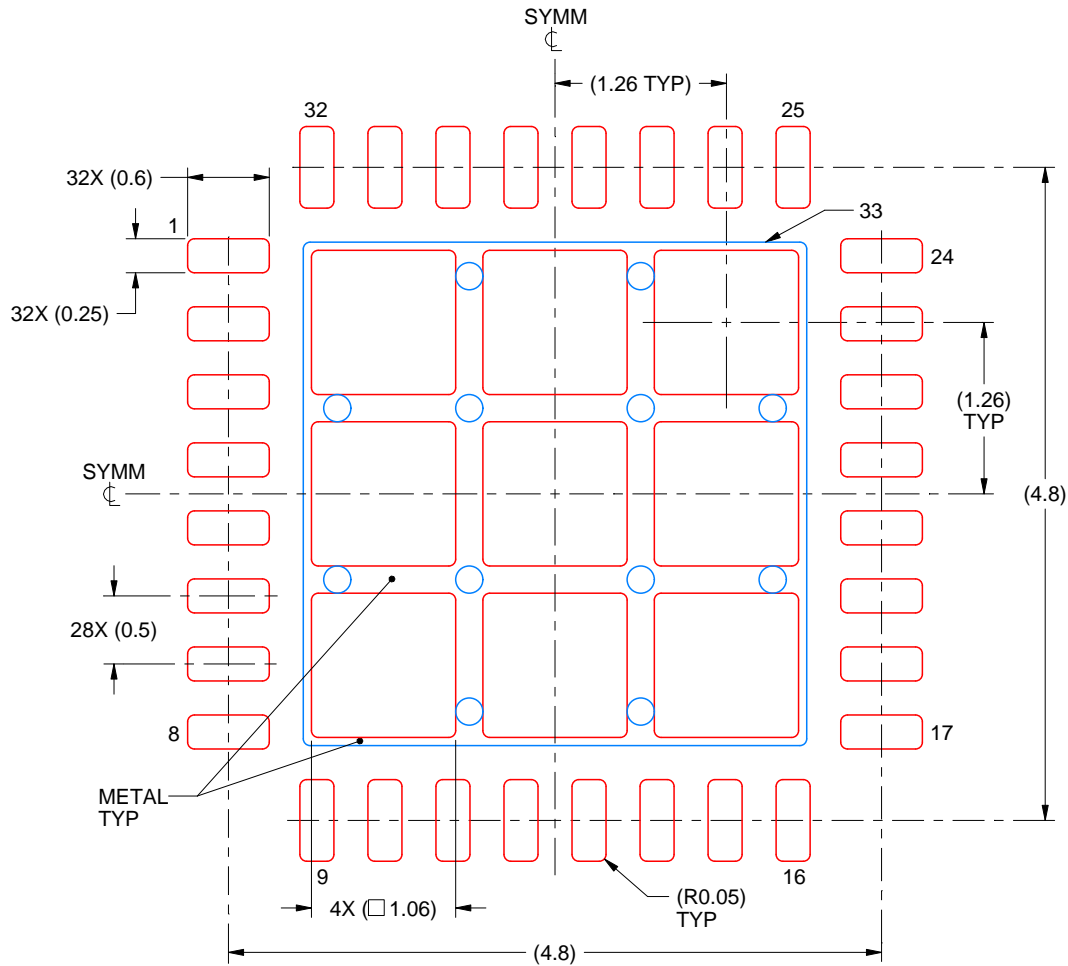

SOLDER PASTE EXAMPLE
 BASED ON 0.125 mm THICK STENCIL

EXPOSED PAD 33:
 74% PRINTED SOLDER COVERAGE BY AREA UNDER PACKAGE
 SCALE:18X

4219073/A 03/2017

NOTES: (continued)

6. Laser cutting apertures with trapezoidal walls and rounded corners may offer better paste release. IPC-7525 may have alternate design recommendations.

MECHANICAL DATA

RHB (S-PVQFN-N32)

PLASTIC QUAD FLATPACK NO-LEAD

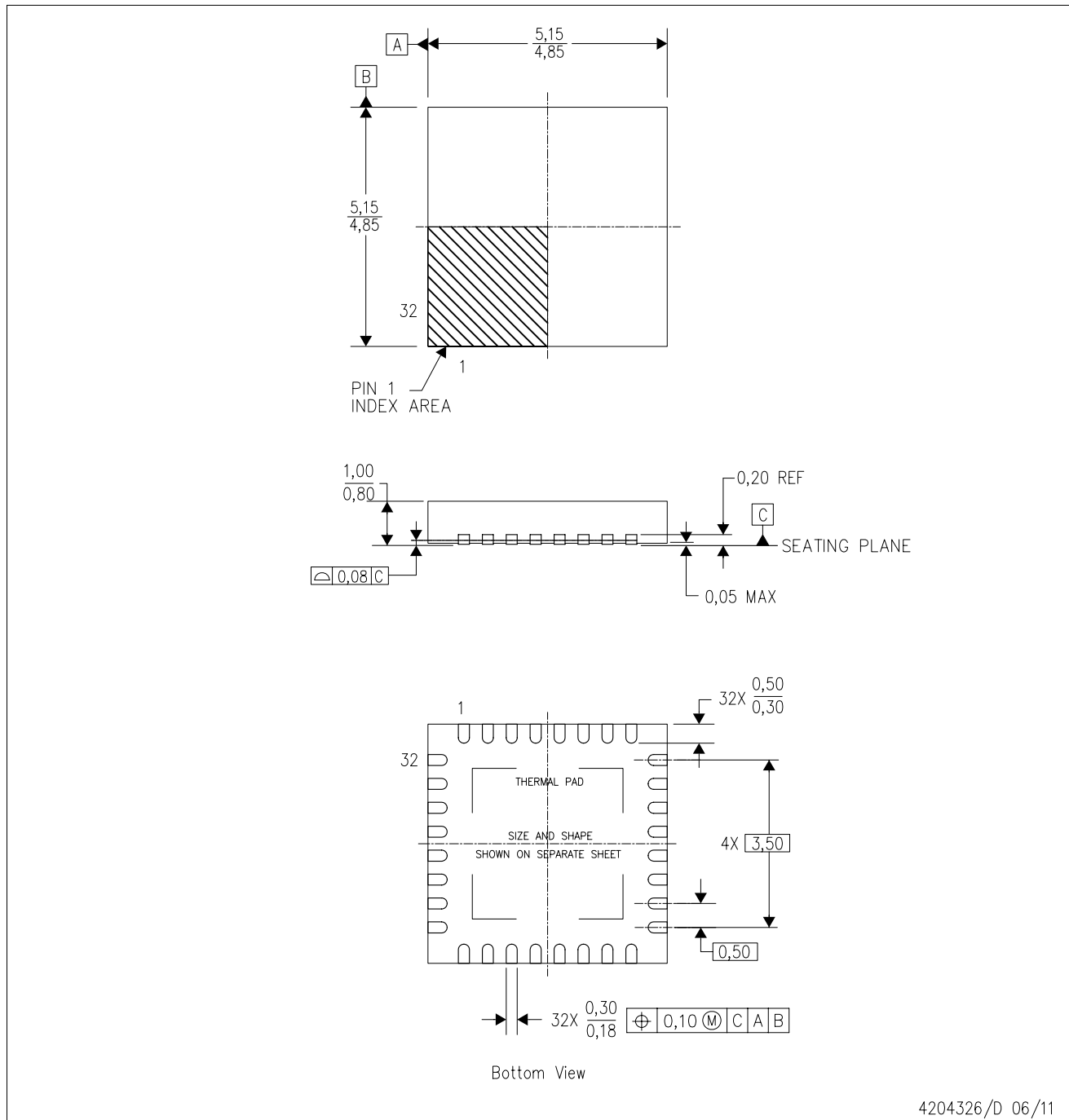

4204326/D 06/11

- NOTES:
- All linear dimensions are in millimeters. Dimensioning and tolerancing per ASME Y14.5M-1994.
 - This drawing is subject to change without notice.
 - QFN (Quad Flatpack No-Lead) Package configuration.
 - The package thermal pad must be soldered to the board for thermal and mechanical performance.
 - See the additional figure in the Product Data Sheet for details regarding the exposed thermal pad features and dimensions.
 - Falls within JEDEC MO-220.

THERMAL INFORMATION

This package incorporates an exposed thermal pad that is designed to be attached directly to an external heatsink. The thermal pad must be soldered directly to the printed circuit board (PCB). After soldering, the PCB can be used as a heatsink. In addition, through the use of thermal vias, the thermal pad can be attached directly to the appropriate copper plane shown in the electrical schematic for the device, or alternatively, can be attached to a special heatsink structure designed into the PCB. This design optimizes the heat transfer from the integrated circuit (IC).

For information on the Quad Flatpack No-Lead (QFN) package and its advantages, refer to Application Report, QFN/SON PCB Attachment, Texas Instruments Literature No. SLUA271. This document is available at www.ti.com.

The exposed thermal pad dimensions for this package are shown in the following illustration.

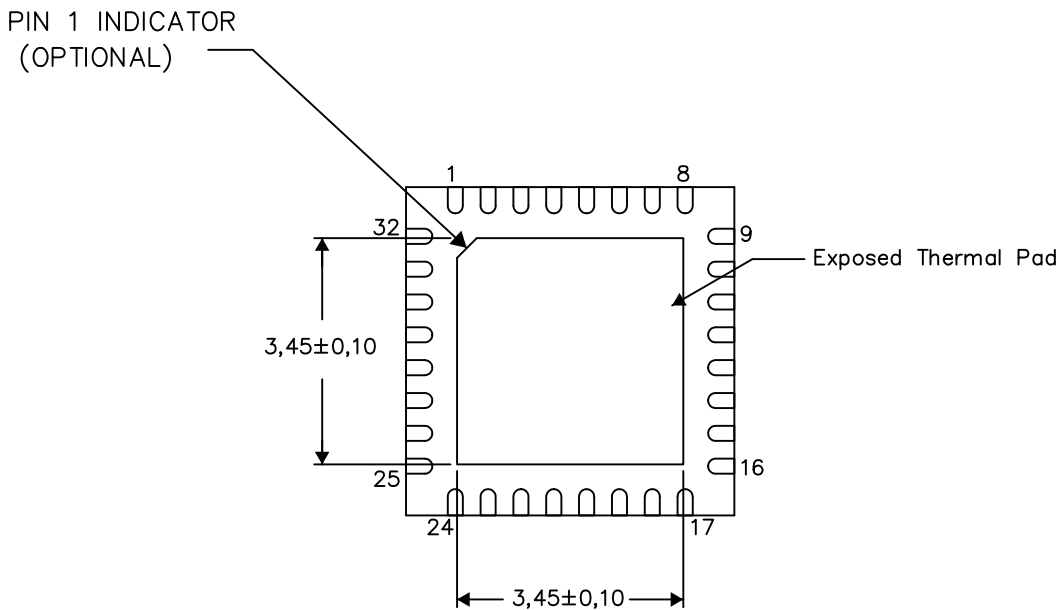

Bottom View

Exposed Thermal Pad Dimensions

4206356-2/AC 05/15

NOTE: A. All linear dimensions are in millimeters

RHB (S-PVQFN-N32)

PLASTIC QUAD FLATPACK NO-LEAD

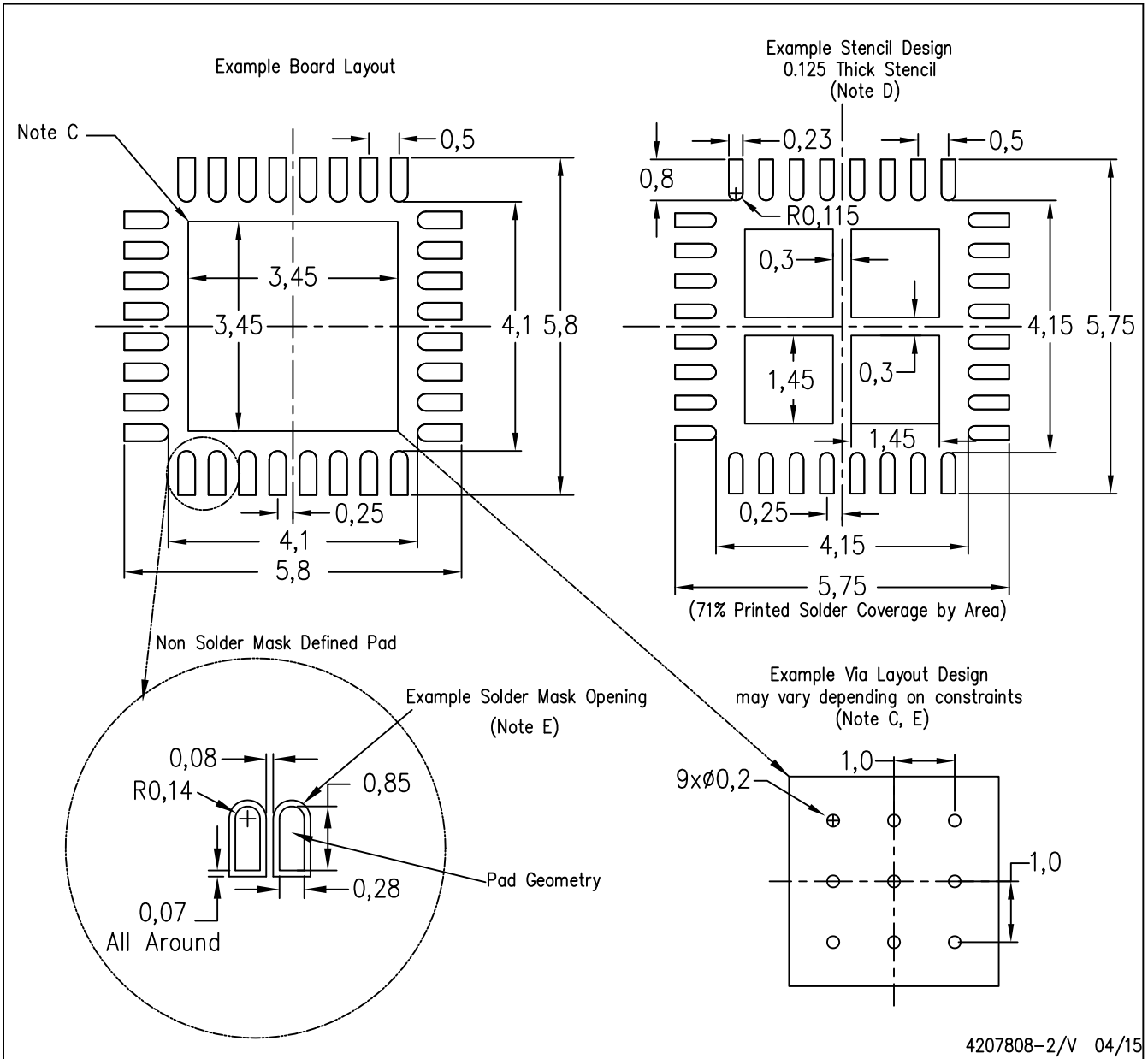

- NOTES:
- All linear dimensions are in millimeters.
 - This drawing is subject to change without notice.
 - This package is designed to be soldered to a thermal pad on the board. Refer to Application Note, Quad Flat-Pack Packages, Texas Instruments Literature No. SLUA271, and also the Product Data Sheets for specific thermal information, via requirements, and recommended board layout. These documents are available at www.ti.com <<http://www.ti.com>>.
 - Laser cutting apertures with trapezoidal walls and also rounding corners will offer better paste release. Customers should contact their board assembly site for stencil design recommendations. Refer to IPC 7525 for stencil design considerations.
 - Customers should contact their board fabrication site for recommended solder mask tolerances and via tenting recommendations for any larger diameter vias placed in the thermal pad.

IMPORTANT NOTICE

Texas Instruments Incorporated (TI) reserves the right to make corrections, enhancements, improvements and other changes to its semiconductor products and services per JESD46, latest issue, and to discontinue any product or service per JESD48, latest issue. Buyers should obtain the latest relevant information before placing orders and should verify that such information is current and complete.

TI's published terms of sale for semiconductor products (<http://www.ti.com/sc/docs/stdterms.htm>) apply to the sale of packaged integrated circuit products that TI has qualified and released to market. Additional terms may apply to the use or sale of other types of TI products and services.

Reproduction of significant portions of TI information in TI data sheets is permissible only if reproduction is without alteration and is accompanied by all associated warranties, conditions, limitations, and notices. TI is not responsible or liable for such reproduced documentation. Information of third parties may be subject to additional restrictions. Resale of TI products or services with statements different from or beyond the parameters stated by TI for that product or service voids all express and any implied warranties for the associated TI product or service and is an unfair and deceptive business practice. TI is not responsible or liable for any such statements.

Buyers and others who are developing systems that incorporate TI products (collectively, "Designers") understand and agree that Designers remain responsible for using their independent analysis, evaluation and judgment in designing their applications and that Designers have full and exclusive responsibility to assure the safety of Designers' applications and compliance of their applications (and of all TI products used in or for Designers' applications) with all applicable regulations, laws and other applicable requirements. Designer represents that, with respect to their applications, Designer has all the necessary expertise to create and implement safeguards that (1) anticipate dangerous consequences of failures, (2) monitor failures and their consequences, and (3) lessen the likelihood of failures that might cause harm and take appropriate actions. Designer agrees that prior to using or distributing any applications that include TI products, Designer will thoroughly test such applications and the functionality of such TI products as used in such applications.

TI's provision of technical, application or other design advice, quality characterization, reliability data or other services or information, including, but not limited to, reference designs and materials relating to evaluation modules, (collectively, "TI Resources") are intended to assist designers who are developing applications that incorporate TI products; by downloading, accessing or using TI Resources in any way, Designer (individually or, if Designer is acting on behalf of a company, Designer's company) agrees to use any particular TI Resource solely for this purpose and subject to the terms of this Notice.

TI's provision of TI Resources does not expand or otherwise alter TI's applicable published warranties or warranty disclaimers for TI products, and no additional obligations or liabilities arise from TI providing such TI Resources. TI reserves the right to make corrections, enhancements, improvements and other changes to its TI Resources. TI has not conducted any testing other than that specifically described in the published documentation for a particular TI Resource.

Designer is authorized to use, copy and modify any individual TI Resource only in connection with the development of applications that include the TI product(s) identified in such TI Resource. NO OTHER LICENSE, EXPRESS OR IMPLIED, BY ESTOPPEL OR OTHERWISE TO ANY OTHER TI INTELLECTUAL PROPERTY RIGHT, AND NO LICENSE TO ANY TECHNOLOGY OR INTELLECTUAL PROPERTY RIGHT OF TI OR ANY THIRD PARTY IS GRANTED HEREIN, including but not limited to any patent right, copyright, mask work right, or other intellectual property right relating to any combination, machine, or process in which TI products or services are used. Information regarding or referencing third-party products or services does not constitute a license to use such products or services, or a warranty or endorsement thereof. Use of TI Resources may require a license from a third party under the patents or other intellectual property of the third party, or a license from TI under the patents or other intellectual property of TI.

TI RESOURCES ARE PROVIDED "AS IS" AND WITH ALL FAULTS. TI DISCLAIMS ALL OTHER WARRANTIES OR REPRESENTATIONS, EXPRESS OR IMPLIED, REGARDING RESOURCES OR USE THEREOF, INCLUDING BUT NOT LIMITED TO ACCURACY OR COMPLETENESS, TITLE, ANY EPIDEMIC FAILURE WARRANTY AND ANY IMPLIED WARRANTIES OF MERCHANTABILITY, FITNESS FOR A PARTICULAR PURPOSE, AND NON-INFRINGEMENT OF ANY THIRD PARTY INTELLECTUAL PROPERTY RIGHTS. TI SHALL NOT BE LIABLE FOR AND SHALL NOT DEFEND OR INDEMNIFY DESIGNER AGAINST ANY CLAIM, INCLUDING BUT NOT LIMITED TO ANY INFRINGEMENT CLAIM THAT RELATES TO OR IS BASED ON ANY COMBINATION OF PRODUCTS EVEN IF DESCRIBED IN TI RESOURCES OR OTHERWISE. IN NO EVENT SHALL TI BE LIABLE FOR ANY ACTUAL, DIRECT, SPECIAL, COLLATERAL, INDIRECT, PUNITIVE, INCIDENTAL, CONSEQUENTIAL OR EXEMPLARY DAMAGES IN CONNECTION WITH OR ARISING OUT OF TI RESOURCES OR USE THEREOF, AND REGARDLESS OF WHETHER TI HAS BEEN ADVISED OF THE POSSIBILITY OF SUCH DAMAGES.

Unless TI has explicitly designated an individual product as meeting the requirements of a particular industry standard (e.g., ISO/TS 16949 and ISO 26262), TI is not responsible for any failure to meet such industry standard requirements.

Where TI specifically promotes products as facilitating functional safety or as compliant with industry functional safety standards, such products are intended to help enable customers to design and create their own applications that meet applicable functional safety standards and requirements. Using products in an application does not by itself establish any safety features in the application. Designers must ensure compliance with safety-related requirements and standards applicable to their applications. Designer may not use any TI products in life-critical medical equipment unless authorized officers of the parties have executed a special contract specifically governing such use. Life-critical medical equipment is medical equipment where failure of such equipment would cause serious bodily injury or death (e.g., life support, pacemakers, defibrillators, heart pumps, neurostimulators, and implantables). Such equipment includes, without limitation, all medical devices identified by the U.S. Food and Drug Administration as Class III devices and equivalent classifications outside the U.S.

TI may expressly designate certain products as completing a particular qualification (e.g., Q100, Military Grade, or Enhanced Product). Designers agree that it has the necessary expertise to select the product with the appropriate qualification designation for their applications and that proper product selection is at Designers' own risk. Designers are solely responsible for compliance with all legal and regulatory requirements in connection with such selection.

Designer will fully indemnify TI and its representatives against any damages, costs, losses, and/or liabilities arising out of Designer's non-compliance with the terms and provisions of this Notice.