

CC3120MOD SimpleLink™ Wi-Fi CERTIFIED™ Network Processor Internet-of-Things Module Solution for MCU Applications

1 Module Overview

1.1 Features

- The CC3120MOD is a Wi-Fi® Module Which Includes the CC3120RNMARGK Wi-Fi Network Processor (NWP). The Fully Integrated, Industrial Temperature Grade, Green Module Includes All Required Clocks, Serial Peripheral Interface (SPI) Flash, and Passives.
- FCC, IC, CE, MIC, and SRRC Certified
- Wi-Fi CERTIFIED™ Modules, With Ability to Request Certificate Transfer for Wi-Fi Alliance Members
- Featuring a Dedicated Internet-on-a chip™ Wi-Fi NWP Which Completely Offloads Wi-Fi and Internet Protocols from the Application MCU
- Wi-Fi Modes
 - 802.11b/g/n Station
 - 802.11b/g/n Access Point (AP) Supporting up to Four Stations
 - Wi-Fi Direct® Client/Group Owner
- WPA2 Personal and Enterprise Security: WEP, WPA/WPA2 PSK, WPA2 Enterprise (802.1x)
- IPv4 and IPv6 TCP/IP Stack
 - Industry-Standard BSD Socket Application Programming Interfaces (APIs)
 - 16 Simultaneous TCP or UDP Sockets
 - 6 Simultaneous TLS and SSL Sockets
- IP Addressing: Static IP, LLA, DHCPv4, and DHCPv6 With Duplicate Address Detection (DAD)
- SimpleLink™ Connection Manager for Autonomous and Fast Wi-Fi Connections
- Flexible Wi-Fi Provisioning With SmartConfig™ Technology, AP Mode, and WPS2 Options
- RESTful API Support Using Internal HTTP Server
- Wide Set of Security Features
 - Hardware Features
 - Separate Execution Environments
 - Device Identity
 - Networking Security
 - Personal and Enterprise Wi-Fi Security
 - Secure Sockets (SSLv3, TLS1.0/1.1/TLS1.2)
 - HTTPS Server
 - Trusted Root-Certificate Catalog
 - TI Root-of-Trust Public key
- Software IP Protection
 - Secure Key Storage
 - File System Security
 - Software Tamper Detection
 - Cloning Protection
- Embedded Network Applications Running on a Dedicated NWP
 - HTTP/HTTPS Web Server With Dynamic User Callbacks
 - mDNS, DNS-SD, DHCP Server
 - Ping
- Recovery Mechanism – Ability to Recover to Factory Defaults
- Wi-Fi TX Power
 - 17.0 dBm at 1 DSSS
 - 13.5 dBm at 54 OFDM
- Wi-Fi RX Sensitivity
 - –95.0 dBm at 1 DSSS
 - –73.5 dBm at 54 OFDM
- Application Throughput
 - UDP: 16 Mbps
 - TCP: 13 Mbps
- Power-Management Subsystem
 - Integrated DC-DC Converters Support a Wide Range of Supply Voltage:
 - V_{BAT} Wide-Voltage Mode: 2.3 V to 3.6 V
 - Advanced Low-Power Modes
 - Shutdown: 1 μ A
 - Hibernate: 5 μ A
 - Low-Power Deep Sleep (LPDS): 115 μ A
 - RX Traffic: 59 mA at 54 OFDM
 - TX Traffic: 229 mA at 54 OFDM, Maximum Power
 - Idle Connected (MCU in LPDS): 690 μ A at DTIM = 1
- Additional Integrated Components on Module
 - 40.0-MHz Crystal With Internal Oscillator
 - 32.768-kHz Crystal (RTC)
 - 32-Mbit SPI Serial Flash
 - RF Filter and Passive Components
- LGA Package
 - 1.27-mm Pitch, 63-Pin, 20.5-mm \times 17.5-mm LGA Package for Easy Assembly and Low-Cost PCB Design



- Operating Temperature
 - Ambient Temperature Range: –40°C to +85°C
- Module Supports [SimpleLink Developers Ecosystem](#)

1.2 Applications

- For Internet-of-Things (IoT) applications, such as:
 - Cloud Connectivity
 - Internet Gateway
 - Home and Building Automation
 - Appliances
 - Access Control
 - Security Systems
 - Smart Energy
 - Industrial Control
 - Smart Plug and Metering
 - Wireless Audio
 - IP Network Sensor Nodes
 - Asset Tracking
 - Medical Devices

1.3 Description

Add Wi-Fi® to low-cost, low-power MCU for IoT applications. The CC3120MOD is an FCC, IC, CE, MIC, SRRC, and Wi-Fi CERTIFIED™ module that is part of the new SimpleLink Wi-Fi family, which dramatically simplifies the implementation of Internet connectivity. The CC3120MOD integrates all protocols for Wi-Fi and Internet, which greatly minimize host MCU software requirements. With built-in security protocols, the CC3120MOD solution provides a robust and simple security experience. Additionally, the CC3120MOD is a complete platform solution including various tools and software, sample applications, user and programming guides, reference designs, and the TI E2E™ support community. The CC3120MOD is available in an LGA package that is easy to lay out with all required components including serial Flash, RF filter, crystal, and passive components that are fully integrated.

The Wi-Fi network processor subsystem features a Wi-Fi Internet-on-a-chip and contains an additional dedicated ARM® MCU that off-loads many of the networking activities from the host MCU. This subsystem includes an 802.11 b/g/n radio, baseband, and MAC with a powerful crypto engine for fast, secure Internet connections with 256-bit encryption. The CC3120MOD module supports station, access point, and Wi-Fi direct modes. The module supports WPA2 personal and enterprise security. This subsystem includes embedded TCP/IP, TLS/SSL stacks, an HTTP server, and multiple Internet protocols. The CC3120MOD module supports a variety of Wi-Fi provisioning methods, including HTTP based on AP mode, SmartConfig™ technology, and WPS2.0.

As part of TI's SimpleLink Wi-Fi family second generation, the CC3120MOD module introduces the new features and enhanced capabilities, such as the following:

- IPv6
- Enhanced Wi-Fi provisioning
- Optimized low-power management
- Wi-Fi AP connection with up to four stations
- More concurrently opened BSD sockets and up to 16 BSD sockets, of which 6 are secure
- HTTPS support
- RESTful API support
- Asymmetric keys
- Crypto library

The power-management subsystem includes an integrated DC-DC converter with support for a wide range of supply voltages. This subsystem enables low-power consumption modes such as hibernate with RTC and shutdown, which requires approximately 5 μ A and 1 μ A of current, respectively. The CC3120MOD module is delivered with a slim and user-friendly host driver to simplify the integration and development of network applications. The host driver can easily be ported to most platforms and operating systems (OS). It is written in strict ANSI-C (C99) and requires minimal platform adaptation layer (porting layer). The CC3120MOD module can connect to any 8-, 16-, or 32-bit MCU over the SPI or UART Interface. The device driver minimizes the host memory footprint requirements of less than 7KB of code memory and 700B of RAM for a TCP client application.

The CC3120MOD module is part of the SimpleLink™ microcontroller (MCU) platform which consists of Wi-Fi, *Bluetooth*® low energy, Sub-1 GHz and host MCUs, which all share a common, easy-to-use development environment with a single core software development kit (SDK) and rich tool set. A one-time integration of the SimpleLink platform enables you to add any combination of the portfolio's devices into your design, allowing 100 percent code reuse when your design requirements change.

The CC3120MOD modules comes in an easy-to-layout LGA package and is delivered as a complete platform solution including various tools and software, sample applications, user and programming guides, reference designs, and the TI E2E™ support community. The module family is also part of the SimpleLink MCU portfolio and supports the SimpleLink developers ecosystem. For more information, visit www.ti.com/SimpleLink.

Table 1-1. Module Information⁽¹⁾

PART NUMBER	PACKAGE	BODY SIZE
CC3120MODRNMMOBR	MOB (63)	20.5 mm x 17.5 mm

(1) For more information, see [Section 10](#).

1.4 Functional Block Diagrams

Figure 1-1 shows the functional block diagram of the CC3120MOD module.

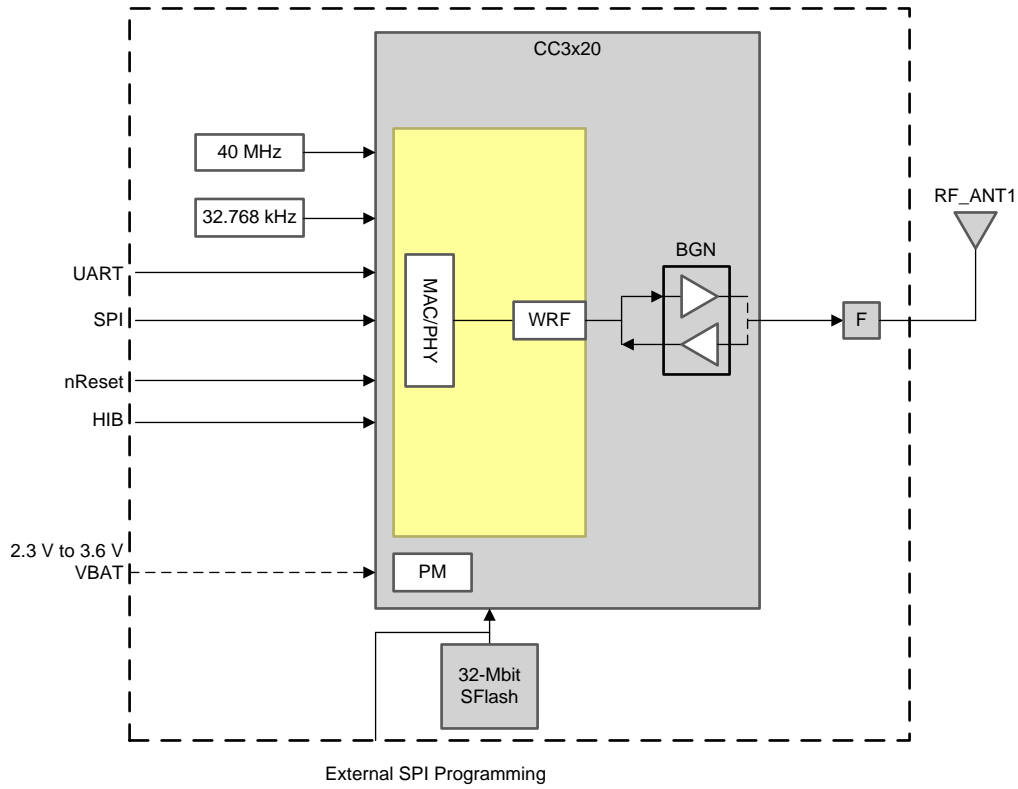

Copyright © 2017, Texas Instruments Incorporated

Figure 1-1. CC3120MOD Module Functional Block Diagram

Figure 1-2 shows the CC3120 hardware overview.

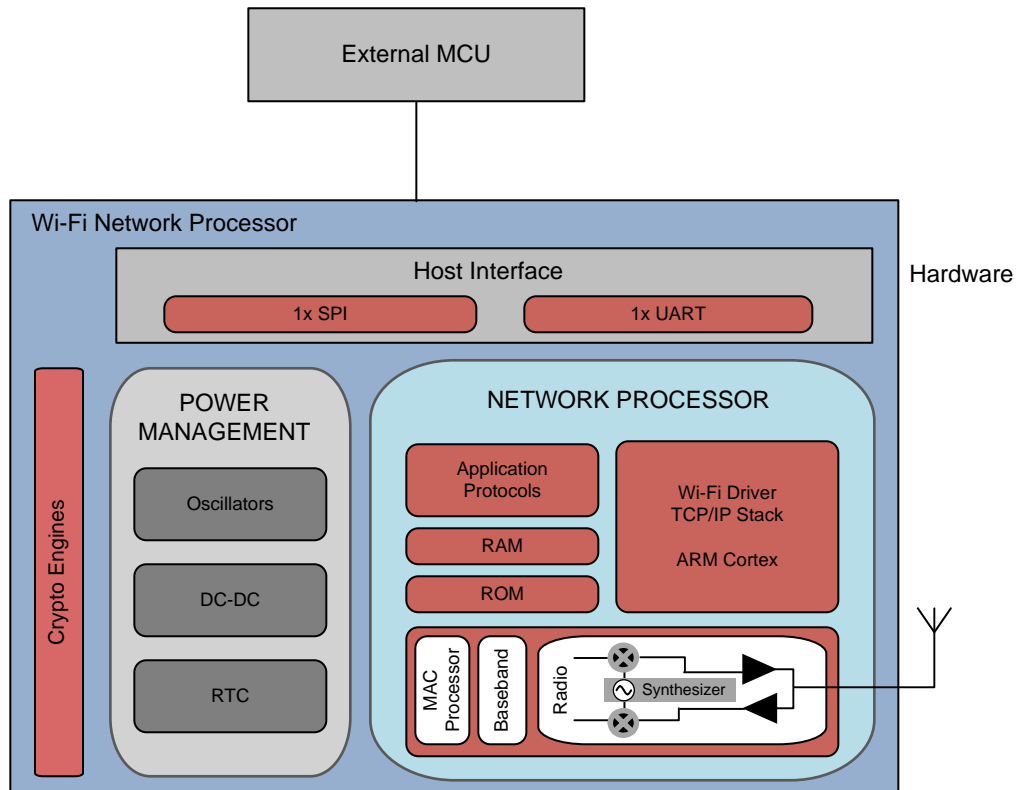

Copyright © 2017, Texas Instruments Incorporated

Figure 1-2. CC3120 Hardware Overview

Figure 1-3 shows an overview of the CC3120 embedded software.

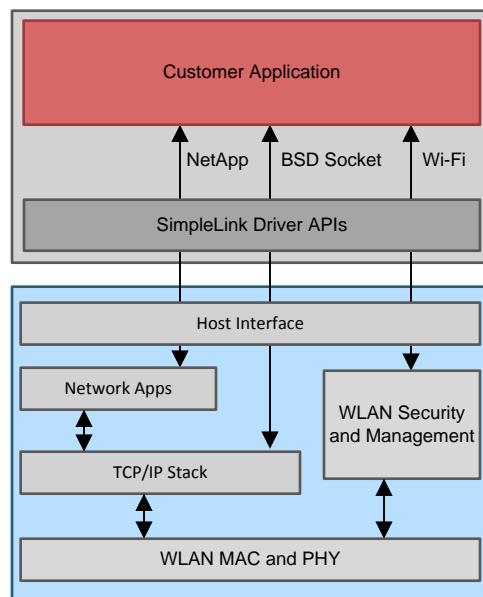

Copyright © 2017, Texas Instruments Incorporated

Figure 1-3. CC3120 Embedded Software Overview

Table of Contents

1	Module Overview	1	6.3	Power-Management Subsystem	31
1.1	Features	1	6.4	Low-Power Operating Modes	31
1.2	Applications	2	6.5	Restoring Factory Default Configuration	32
1.3	Description	2	6.6	Device Certification and Qualification	32
1.4	Functional Block Diagrams	4	6.7	Module Markings	34
2	Revision History	7	6.8	End Product Labeling	35
3	Device Comparison	8	6.9	Manual Information to the End User	35
3.1	Related Products	9	7	Applications, Implementation, and Layout	36
4	Terminal Configuration and Functions	10	7.1	Application Information	36
4.1	CC3120MOD Pin Diagram	10	7.2	PCB Layout Guidelines	39
4.2	Pin Attributes	11	8	Environmental Requirements and Specifications	45
4.3	Connections for Unused Pins	13	8.1	Temperature	45
5	Specifications	14	8.2	Handling Environment	45
5.1	Absolute Maximum Ratings	14	8.3	Storage Condition	45
5.2	ESD Ratings	14	8.4	Baking Conditions	45
5.3	Recommended Operating Conditions	14	8.5	Soldering and Reflow Condition	46
5.4	Current Consumption Summary	15	9	Device and Documentation Support	47
5.5	TX Power and IBAT versus TX Power Level Settings	16	9.1	Device Nomenclature	47
5.6	Brownout and Blackout Conditions	18	9.2	Development Tools and Software	47
5.7	Electrical Characteristics	19	9.3	Firmware Updates	48
5.8	WLAN Receiver Characteristics	20	9.4	Documentation Support	48
5.9	WLAN Transmitter Characteristics	20	9.5	Trademarks	50
5.10	Reset Requirement	20	9.6	Electrostatic Discharge Caution	50
5.11	Thermal Resistance Characteristics for MOB Package	20	9.7	Export Control Notice	50
5.12	Timing and Switching Characteristics	21	9.8	Glossary	50
5.13	External Interfaces	23	10	Mechanical, Packaging, and Orderable Information	51
6	Detailed Description	27	10.1	Mechanical, Land, and Solder Paste Drawings	51
6.1	Overview	27	10.2	Package Option Addendum	52
6.2	Module Features	27	10.3	Tape and Reel Information	53

2 Revision History

Changes from March 3, 2017 to June 20, 2017		Page
• Updated <i>Features</i>		1
• Changed document status from Advance Information to Production Data.....		1
• Updated <i>Description</i>		2
• Changed <i>CC3120MOD Module Functional Block Diagram</i>		4
• Changed <i>CC3120MOD Pin Diagram Bottom View</i>		10
• Updated <i>Module Pin Attributes</i> table		11
• Deleted <i>Power-On Hours (POH)</i>		14
• Added peak calibration current value 3.6 V in <i>Current Consumption Summary</i>		15
• Changed Idle connected TYP value from 715 in <i>Current Consumption Summary</i>		15
• Updated V_{OH} and V_{OL} paramters in <i>Electrical Characteristics</i> table		19
• Changed TYP values in <i>WLAN Receiver Characteristics</i> table		20
• Changed TYP values in <i>WLAN Transmitter Characteristics</i> table		20
• Added <i>Power Supply Sequencing</i>		21
• Changed <i>Host SPI Timing</i> diagram and table		23
• Changed <i>Typical 5-Wire UART Topology</i> figure		25
• Changed <i>4-Wire UART Configuration</i> figure		25
• Changed <i>3-Wire UART Topology</i> figure		25
• Added battery drain information to <i>Hibernate</i>		31
• Added battery drain information to <i>Shutdown</i>		31
• Changed <i>Device Certification and Qualification</i> and <i>CC3120MOD List of Certifications</i> table		32
• Changed <i>FCC Certification and Statement</i>		32
• Changed <i>Industry Canada (IC) Certification and Statement</i> section		33
• Added <i>ETSI/CE Certification</i>		33
• Added <i>Japan MIC Certification</i>		33
• Added <i>SRRC Certification and Statement</i>		34
• Added <i>Module Markings</i>		34
• Added FCC ID, IC, and JP certification information to <i>End Product Labeling</i>		35
• Updated <i>CC3120MOD Module Reference Schematic</i>		37
• Changed <i>PCB Layout Guidelines</i>		39
• Changed <i>Top Layer Copper Pull Back on RF Pads</i> figure		41
• Changed CC3120 Radio Certification wiki page link in <i>Antenna Guidelines</i> table		42
• Changed H parameter value in <i>Recommended PCB Values for 2-Layer Board (L1 to L2 = 41.8 mils)</i> table		44
• Updated documentation references in <i>Device and Documentation Support</i>		47
• Added note to <i>Mechanical Drawing</i>		51

3 Device Comparison

Table 3-1 shows the features supported across different CC3x20 modules.

Table 3-1. Device Features Comparison

FEATURE	DEVICE		
	CC3120MOD	CC3220MODS	CC3220MODSF
Onboard Chip	CC3120	CC3220S	CC3220SF
Onboard ANT	No	No	No
sFlash	32-Mbit	32-Mbit	32-Mbit
Regulatory Certification	FCC, IC, CE, MIC, SRRC	FCC, IC, CE, MIC, SRRC	FCC, IC, CE, MIC, SRRC
Wi-Fi Alliance Certification	Yes	Yes	Yes
Input Voltage	2.3 V to 3.6 V	2.3 V to 3.6 V	2.3 V to 3.6 V
Package	17.5 mm x 20.5 mm LGA	17.5 mm x 20.5 mm LGA	17.5 mm x 20.5 mm LGA
Operating Temperature Range	-40° to 85°C	-40° to 85°C	-40° to 85°C
Classification	Wi-Fi Network Processor	Wireless Microcontroller	Wireless Microcontroller
Standard	802.11 b/g/n	802.11 b/g/n	802.11 b/g/n
Frequency	2.4 GHz	2.4 GHz	2.4 GHz
TCP / IP Stack	IPv4, IPv6	IPv4, IPv6	IPv4, IPv6
Sockets	16	16	16
Integrated MCU	-	ARM Cortex®- M4® at 80 MHz	ARM Cortex-M4 at 80 MHz
On Chip Memory			
RAM	-	256KB	256KB
Flash	-	-	1MB
Peripherals and Interfaces			
Universal Asynchronous Receiver and Transmitter (UART)	1	2	2
Serial Port Interface (SPI)	1	1	1
Multi-Channel Audio Serial Port (McASP)- I2S or PCM	-	2-ch	2-ch
Inter-Integrated Circuit (I ² C)	-	1	1
Analog to Digital Converter (ADC)	-	4-ch, 12-bit	4-ch, 12-bit
Parallel Interface (8-bit PI)	-	1	1
General Purposes Timers	-	4	4
Multimedia Card (MMC / SD)	-	1	1
Security Features			
Wi-Fi Level of Security	WEP, WPS, WPA / WPA2 PSK WPA2 (802.1x)	WEP, WPS, WPA / WPA2 PSK WPA2 (802.1x)	WEP, WPS, WPA / WPA2 PSK WPA2 (802.1x)
Secure Sockets (SSL v3 or TLS 1.0 / 1.1 / 1.2)	6	6	6
Additional Networking Security	Unique Device Identity Trusted Root-Certificate Catalog TI Root-of-Trust Public key	Unique Device Identity Trusted Root-Certificate Catalog TI Root-of-Trust Public key	Unique Device Identity Trusted Root-Certificate Catalog TI Root-of-Trust Public key
Hardware Acceleration	Hardware Crypto Engines	Hardware Crypto Engines	Hardware Crypto Engines
Secure Boot	-	Yes	Yes
Enhanced Application Level Security	-	File system security Secure key storage Software tamper detection Cloning protection Initial secure programming	File system security Secure key storage Software tamper detection Cloning protection Initial secure programming

3.1 Related Products

For information about other devices in this family of products or related products see the links below.

The SimpleLink™ MCU Portfolio Offers a single development environment that delivers flexible hardware, software, and tool options for customers developing wired and wireless applications. With 100% code reuse across host MCUs, Wi-Fi, Bluetooth low energy, Sub-1 GHz devices and more, choose the MCU or connectivity standard that fits your design. A one-time investment with the SimpleLink software development kit (SDK) allows you to reuse often, opening the door to create unlimited applications. For more information, visit www.ti.com/simplelink.

SimpleLink™ Wi-Fi® Family Offers several Internet-on-a-chip solutions, which address the need of battery operated, security enabled products. Texas Instruments offers a single chip wireless microcontroller and a wireless network processor which can be paired with any MCU, to allow developers to design new Wi-Fi products, or upgrade existing products with Wi-Fi capabilities. For more information, visit www.ti.com/simplelinkwifi.

MSP432™ Host MCU The MSP432P401R MCU features the ARM® Cortex®-M4 processor offering ample processing capability with floating point unit and memory footprint for advanced processing algorithm, communication protocols as well as application needs, while incorporating a 14-bit 1-mbps ADC14 that provides a flexible and low-power analog with best-in-class performance to enable developers to add differentiated sensing and measurement capabilities to their Wi-Fi applications. For more information, visit www.ti.com/product/MSP432P401R.

Reference Designs for CC3120 and CC3220 Modules The TI Designs Reference Design Library is a robust reference design library spanning analog, embedded processor, and connectivity. Created by TI experts to help you jump start your system design, all TI Designs include schematic or block diagrams, BOMs, and design files to speed your time to market. Search and download designs at www.ti.com/tidesigns.

CC3120 SDK Plug In The CC3120 SDK Plug In contains drivers, many sample applications for Wi-Fi features and Internet, and documentation needed to use the CC3120 solution. Learn more at <http://www.ti.com/cc3120sdk>.

4 Terminal Configuration and Functions

4.1 CC3120MOD Pin Diagram

Figure 4-1 shows the pin diagram for the CC3120MOD module.

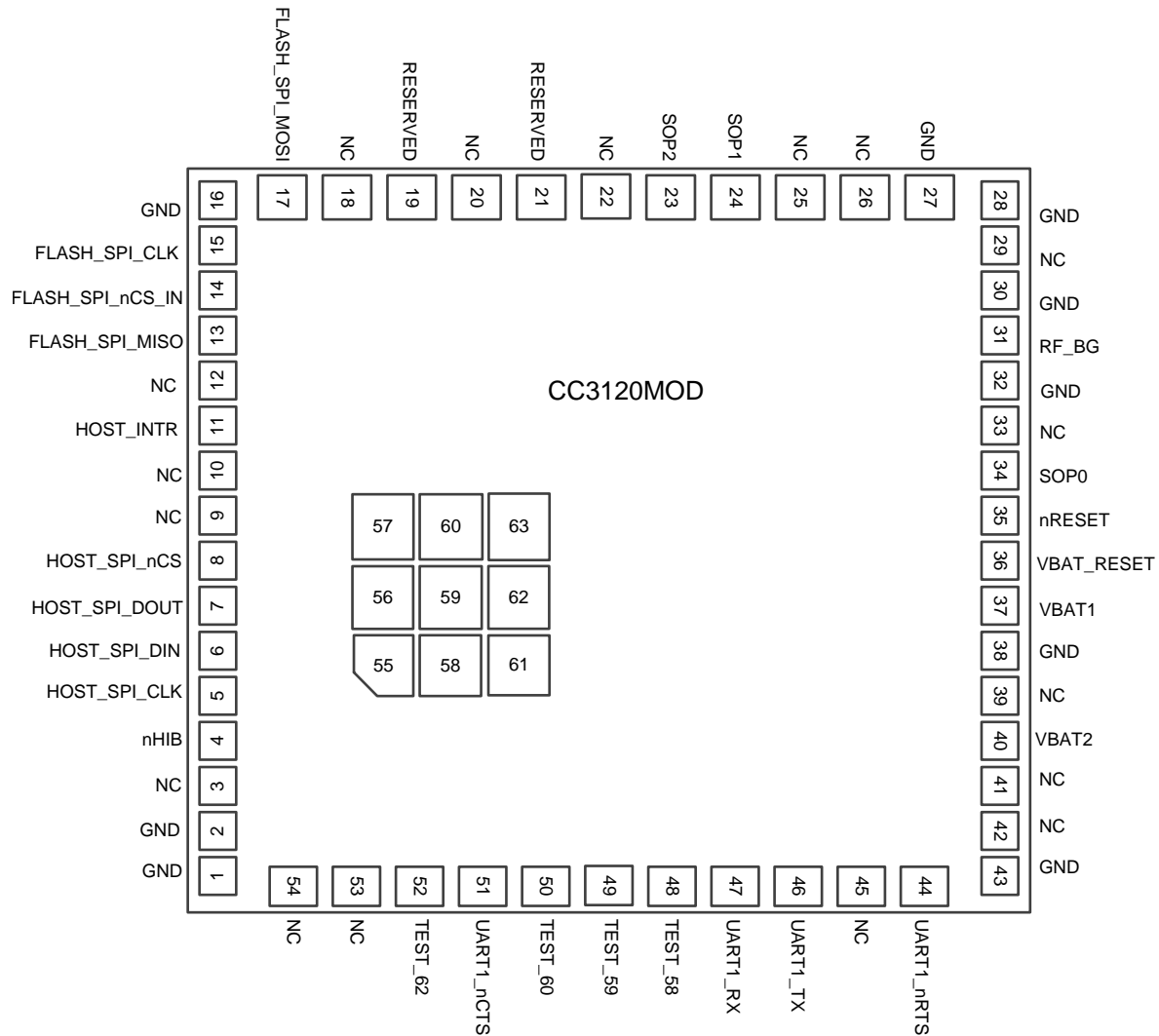

NOTE: Figure 4-1 shows the approximate location of pins on the module. For the actual mechanical diagram, refer to Section 10.

Figure 4-1. CC3120MOD Pin Diagram Bottom View

4.2 Pin Attributes

Table 4-1 lists the pin descriptions of the CC3120MOD module.

NOTE

If an external device drives a positive voltage to signal pads when the CC3120MOD is not powered, DC current is drawn from the other device. If the drive strength of the external device is adequate, an unintentional wake up and boot of the CC3120MOD can occur. To prevent current draw, TI recommends one of the following:

- All devices interfaced to the CC3120MOD must be powered from the same power rail as the CC3120MOD.
- Use level-shifters between the CC3120MOD and any external devices fed from other independent rails.
- The nRESET pin of the CC3120MOD must be held low until the V_{BAT} supply to the module is driven and stable.

Table 4-1. Module Pin Attributes⁽¹⁾

PIN	DEFAULT FUNCTION	STATE AT RESET AND HIBERNATE	I/O TYPE ⁽²⁾	DESCRIPTION
1	GND	N/A	–	Ground
2	GND	N/A	–	Ground
4	nHIB	Hi-Z	I	Hibernate signal, active low. Ensure that the nHIB line does not float at any time.
5	HOST_SPI_CLK	Hi-Z	I	Host interface SPI clock
6	HOST_SPI_DIN	Hi-Z	I	Host interface SPI data input
7	HOST_SPI_DOUT	Hi-Z	O	Host interface SPI data output
8	HOST_SPI_nCS	Hi-Z	I	Host interface SPI chip select (active low)
11	HOST_INTR	Hi-Z	O	Interrupt output
13	FLASH_SPI_MISO	Hi-Z	I	External serial Flash interface: SPI data in
14	FLASH_SPI_nCS_IN	Hi-Z	O	External serial Flash interface: SPI chip select (active low)
15	FLASH_SPI_CLK	Hi-Z	O	External serial Flash interface: SPI clock
16	GND	N/A	–	Ground
17	FLASH_SPI_MOSI	Hi-Z	O	External serial Flash interface: SPI data out
23	SOP2	Hi-Z	–	SOP[2:0] used for factory restore. See Section 6.5 .
24	SOP1	Hi-Z	–	SOP[2:0] used for factory restore. See Section 6.5 .
27	GND	N/A	–	Ground
28	GND	N/A	–	Ground
30	GND	N/A	–	Ground. Reference for RF signal
31	RF_BG	Hi-Z	I/O	2.4-GHz RF input/output
32	GND	N/A	–	Ground. Reference for RF signal
34	SOP0	Hi-Z	–	SOP[2:0] used for factory restore. See Section 6.5 .

(1) Using a configuration file stored on Flash, the vendor can optionally block any possibility of bringing up AP using the FORCE_AP pin.

(2) I = Input, O = Output, RF = Radio frequency, I/O = Bidirectional

Table 4-1. Module Pin Attributes⁽¹⁾ (continued)

PIN	DEFAULT FUNCTION	STATE AT RESET AND HIBERNATE	I/O TYPE ⁽²⁾	DESCRIPTION
35	nRESET	Hi-Z	I	<p>There is an internal 100 kΩ pull-up resistor option from the nRESET pin to VBAT_RESET. Note: VBAT_RESET is not connected to VBAT1 or VBAT2 within the module. The following connection schemes are recommended:</p> <ul style="list-style-type: none"> Connect nRESET to a GPIO from the host only if nRESET will be in a defined state under all operating conditions. Leave VBAT_RESET unconnected to save power. If nRESET cannot be in a defined state under all operating conditions, connect VBAT_RESET to the main module power supply (VBAT1 and VBAT2). Due to the internal pull-up resistor, a leakage current of 3.3 V / 100 kΩ is expected.
36	VBAT_RESET	Hi-Z	–	
37	VBAT1	Hi-Z	–	Power supply for the module, must be connected to battery (2.3 V to 3.6 V)
38	GND	N/A	–	Ground
40	VBAT2	Hi-Z	–	Power supply for the module, must be connected to battery (2.3 V to 3.6 V)
43	GND	N/A	–	Ground
44	UART1_nRTS	Hi-Z	O	UART interface to host (request to send)
46	UART1_TX	Hi-Z	O	UART interface to host (transmit)
47	UART1_RX	Hi-Z	I	UART interface to host (receive)
50	TEST_60	Hi-Z	O	Connect to external test point.
51	UART1_nCTS	Hi-Z	I	UART interface to host (clear to send)
52	TEST_62	Hi-Z	O	Connect to external test point.
55	GND	N/A	–	Thermal Ground
56	GND	N/A	–	Thermal Ground
57	GND	N/A	–	Thermal Ground
58	GND	N/A	–	Thermal Ground
59	GND	N/A	–	Thermal Ground
60	GND	N/A	–	Thermal Ground
61	GND	N/A	–	Thermal Ground
62	GND	N/A	–	Thermal Ground
63	GND	N/A	–	Thermal Ground

4.3 Connections for Unused Pins

All unused pins must be left as no connect (NC) pins. [Table 4-2](#) provides a list of NC pins.

Table 4-2. Connections for Unused Pins

PIN	DEFAULT FUNCTION	STATE AT RESET AND HIBERNATE	I/O TYPE	DESCRIPTION
3	NC	WLAN analog	–	Reserved. Do not connect.
9	NC	WLAN analog	–	Reserved. Do not connect.
10	NC	WLAN analog	–	Reserved. Do not connect.
12	NC	WLAN analog	–	Reserved. Do not connect.
18	NC	WLAN analog	–	Reserved. Do not connect.
19	NC	WLAN analog	–	Reserved. Do not connect.
20	NC	WLAN analog	–	Reserved. Do not connect.
21	NC	WLAN analog	–	Reserved. Do not connect.
25	NC	WLAN analog	–	Reserved. Do not connect.
26	NC	WLAN analog	–	Reserved. Do not connect.
29	NC	WLAN analog	–	Reserved. Do not connect.
33	NC	WLAN analog	–	Reserved. Do not connect.
39	NC	WLAN analog	–	Reserved. Do not connect.
41	NC	WLAN analog	–	Reserved. Do not connect.
42	NC	WLAN analog	–	Reserved. Do not connect.
45	NC	WLAN analog	–	Reserved. Do not connect.
48	NC	WLAN analog	–	Reserved. Do not connect.
49	NC	WLAN analog	–	Reserved. Do not connect.
53	NC	WLAN analog	–	Reserved. Do not connect.
54	NC	WLAN analog	–	Reserved. Do not connect.

5 Specifications

All measurements are references of the module pins, unless otherwise indicated. All specifications are over process and voltage, unless otherwise indicated.

5.1 Absolute Maximum Ratings

These specifications indicate levels where permanent damage to the module can occur. Functional operation is not ensured under these conditions. Operation at absolute maximum conditions for extended periods can adversely affect long-term reliability of the module ⁽¹⁾⁽²⁾.

	MIN	MAX	UNIT
V _{BAT}	-0.5	3.8	V
Digital I/O	-0.5	V _{BAT} + 0.5	V
RF pin	-0.5	2.1	V
Analog pins	-0.5	2.1	V
Operating temperature, T _A	-40	85	°C
Storage temperature, T _{stg}	-40	85	°C
Junction temperature, T _j ⁽³⁾		120	°C

- (1) Stresses beyond those listed under *Absolute Maximum Ratings* may cause permanent damage to the device. These are stress ratings only, and functional operation of the device at these or any other conditions beyond those indicated under *Recommended Operating Conditions* is not implied. Exposure to absolute-maximum-rated conditions for extended periods may affect device reliability.
- (2) All voltage values are with respect to V_{SS}, unless otherwise noted.
- (3) Junction temperature is for the CC3120RNMARGK device that is contained within the module.

5.2 ESD Ratings

			VALUE	UNIT
V _{ESD}	Electrostatic discharge (ESD) performance	Human body model (HBM), per ANSI/ESDA/JEDEC JS001 ⁽¹⁾	±2000	V
		Charged device model (CDM), per JESD22-C101 ⁽²⁾	±500	
		All pins		

- (1) JEDEC document JEP155 states that 500-V HBM allows safe manufacturing with a standard ESD control process.
- (2) JEDEC document JEP157 states that 250-V CDM allows safe manufacturing with a standard ESD control process.

5.3 Recommended Operating Conditions

Function operation is not ensured outside this limit, and operation outside this limit for extended periods can adversely affect long-term reliability of the module ⁽¹⁾⁽²⁾⁽³⁾.

	MIN	TYP	MAX	UNIT
V _{BAT}	2.3	3.3	3.6	V
Operating temperature	-40	25	85	°C
Ambient thermal slew	-20		20	°C/minute

- (1) When operating at an ambient temperature of over 75°C, the transmit duty cycle must remain below 50% to avoid the auto-protect feature of the power amplifier. If the auto-protect feature triggers, the device takes a maximum of 60 seconds to restart the transmission.
- (2) To ensure WLAN performance, ripple on the 2.3-V to 3.6-V supply must be less than ±300 mV.
- (3) The minimum voltage specified includes the ripple on the supply voltage and all other transient dips. The brownout condition is 2.1 V, and care must be taken when operating at the minimum specified voltage.

5.4 Current Consumption Summary

 $T_A = 25^\circ\text{C}$, $V_{\text{BAT}} = 3.6\text{ V}$

PARAMETER	TEST CONDITIONS ⁽¹⁾ ⁽²⁾		MIN	TYP	MAX	UNIT
TX	1 DSSS	TX power level = 0		272		mA
		TX power level = 4		188		
	6 OFDM	TX power level = 0		248		
		TX power level = 4		179		
	54 OFDM	TX power level = 0		223		
		TX power level = 4		160		
RX ⁽³⁾	1 DSSS			53		mA
	54 OFDM			53		
Idle connected ⁽⁴⁾				690		μA
LPDS				115		μA
Hibernate				5		μA
Shutdown				1		μA
Peak calibration current ⁽⁵⁾	$V_{\text{BAT}} = 3.6\text{ V}$			420		mA
	$V_{\text{BAT}} = 3.3\text{ V}$			450		
	$V_{\text{BAT}} = 2.3\text{ V}$			620		

- (1) TX power level = 0 implies maximum power (see [Figure 5-1](#), [Figure 5-2](#), and [Figure 5-3](#)). TX power level = 4 implies output power backed off approximately 4 dB.
- (2) The CC3120MOD system is a constant power-source system. The active current numbers scale inversely on the V_{BAT} voltage supplied.
- (3) The RX current is measured with a 1-Mbps throughput rate.
- (4) DTIM = 1
- (5) The complete calibration can take up to 17 mJ of energy from the battery over a time of 24 ms. In default mode, calibration is performed sparingly, typically when re-enabling the NWP and when the temperature has changed by more than 20°C. There are two additional calibration modes that may be used to reduced or completely eliminate the calibration event. For further details, see the [CC3120](#), [CC3220 SimpleLink™ Wi-Fi® and IoT Network Processor Programmer's Guide](#).

5.5 TX Power and IBAT versus TX Power Level Settings

Figure 5-1, Figure 5-2, and Figure 5-3 show TX Power and IBAT versus TX power level settings for modulations of 1 DSSS, 6 OFDM, and 54 OFDM, respectively.

In Figure 5-1, the area enclosed in the circle represents a significant reduction in current during transition from TX power level 3 to level 4. In the case of lower range requirements (14-dBm output power), TI recommends using TX power level 4 to reduce the current.

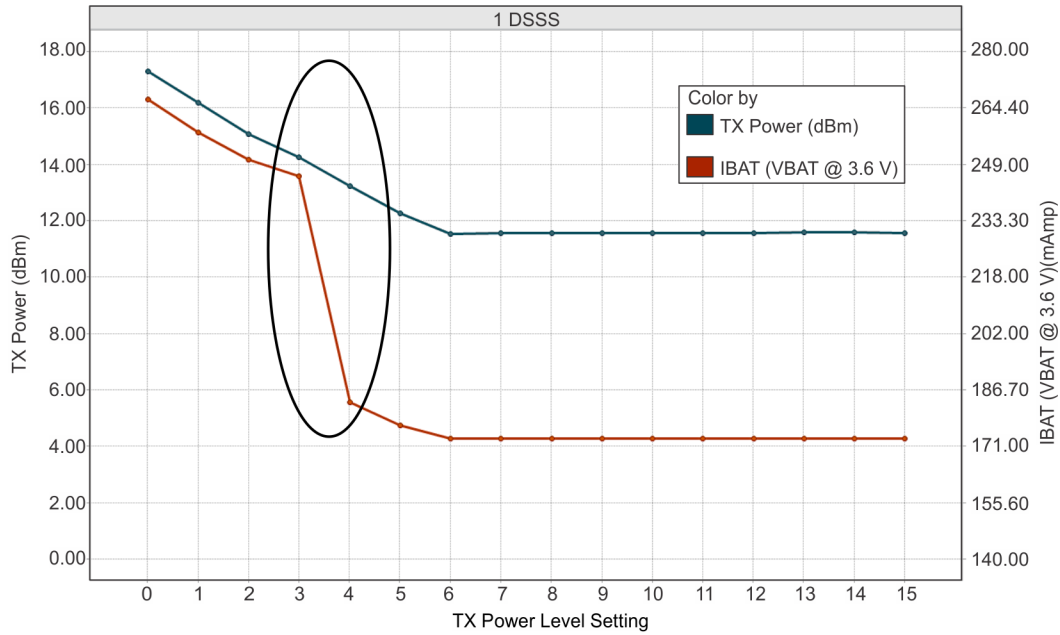

Figure 5-1. TX Power and IBAT vs TX Power Level Settings (1 DSSS)

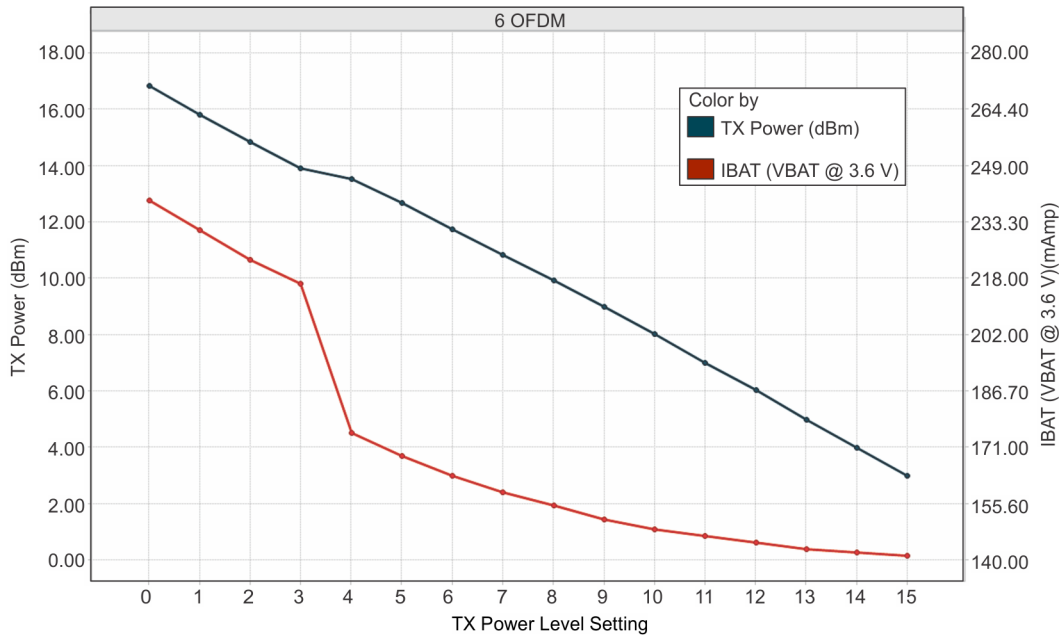

Figure 5-2. TX Power and IBAT vs TX Power Level Settings (6 OFDM)

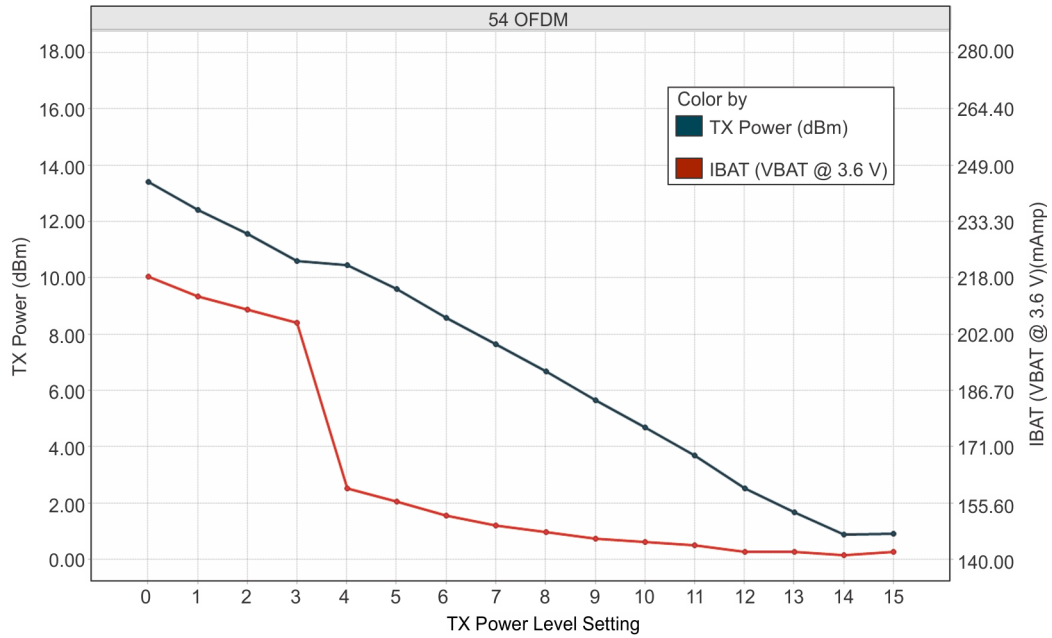

Figure 5-3. TX Power and IBAT vs TX Power Level Settings (54 OFDM)

5.6 Brownout and Blackout Conditions

The device enters a brownout condition when the input voltage dips below $V_{BROWNOUT}$ (see Figure 5-4 and Figure 5-5). This condition must be considered during design of the power supply routing, especially if operating from a battery. High-current operations, such as a TX packet or any external activity (not necessarily related directly to networking) can cause a drop in the supply voltage, potentially triggering a brownout condition. The resistance includes the internal resistance of the battery, contact resistance of the battery holder (four contacts for a 2x AA battery), and the wiring and PCB routing resistance.

NOTE

When the device is in the Hibernate state, brownout is not detected; only blackout is in effect during the Hibernate state.

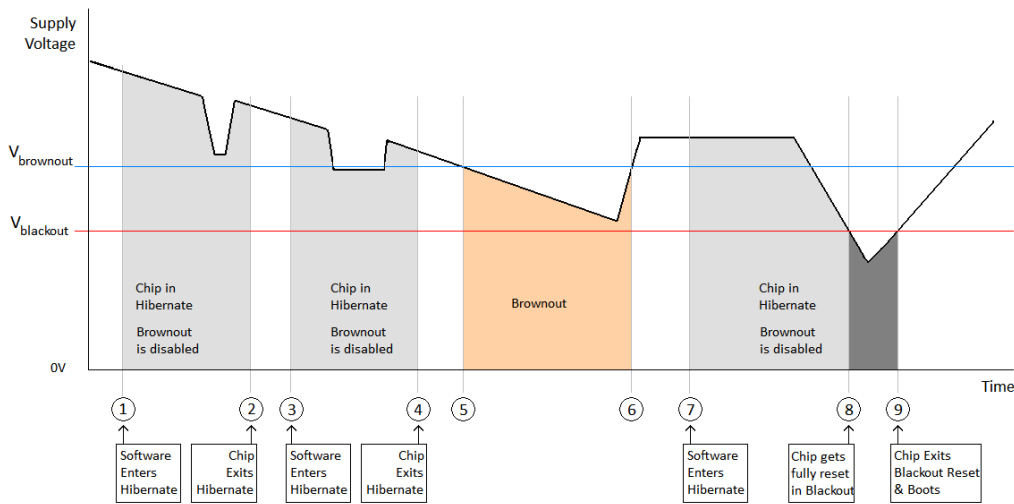

Figure 5-4. Brownout and Blackout Levels (1 of 2)

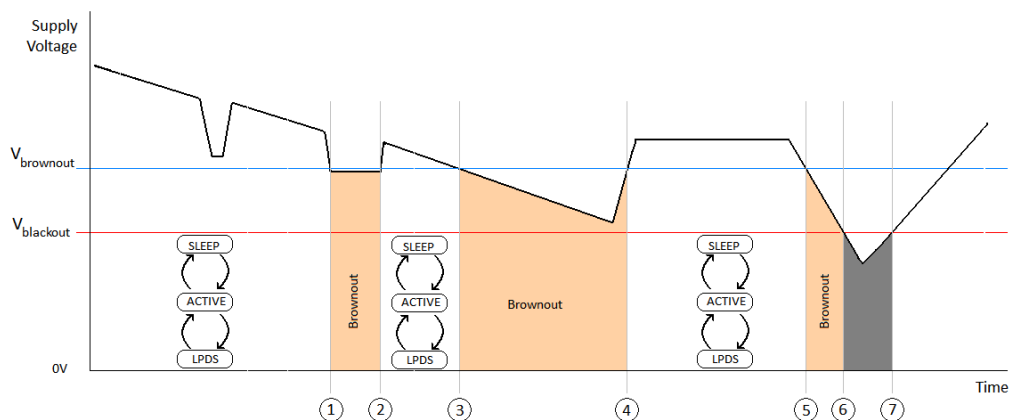

Figure 5-5. Brownout and Blackout Levels (2 of 2)

In the brownout condition, all sections of the CC3120MOD (including the 32-kHz RTC) shut down except for the Hibernate module, which remains on. The current in this state can reach approximately 400 μ A. The blackout condition is equivalent to a hardware reset event in which all states within the device are lost.

Table 5-1 lists the brownout and blackout voltage levels.

Table 5-1. Brownout and Blackout Voltage Levels

CONDITION	VOLTAGE LEVEL	UNIT
V_{brownout}	2.1	V
V_{blackout}	1.67	V

5.7 Electrical Characteristics

 $T_A = 25^\circ\text{C}$, $V_{\text{BAT}} = 3.3\text{ V}$

PARAMETER		TEST CONDITIONS ⁽¹⁾	MIN	NOM	MAX	UNIT
C_{IN}	Pin capacitance			4		pF
V_{IH}	High-level input voltage		$0.65 \times V_{\text{DD}}$		$V_{\text{DD}} + 0.5\text{ V}$	V
V_{IL}	Low-level input voltage		-0.5		$0.35 \times V_{\text{DD}}$	V
I_{IH}	High-level input current			5		nA
I_{IL}	Low-level input current			5		nA
V_{OH}	High-level output voltage	IL = 2 mA; configured I/O drive strength = 2 mA; $2.4\text{ V} \leq V_{\text{DD}} < 3.6\text{ V}$			$V_{\text{DD}} \times 0.8$	V
		IL = 4 mA; configured I/O drive strength = 4 mA; $2.4\text{ V} \leq V_{\text{DD}} < 3.6\text{ V}$			$V_{\text{DD}} \times 0.7$	V
		IL = 8 mA; configured I/O drive strength = 8 mA; $2.4\text{ V} \leq V_{\text{DD}} < 3.6\text{ V}$			$V_{\text{DD}} \times 0.7$	V
		IL = 2 mA; configured I/O drive strength = 2 mA; $2.3\text{ V} \leq V_{\text{DD}} < 2.4\text{ V}$			$V_{\text{DD}} \times 0.75$	V
V_{OL}	Low-level output voltage	IL = 2 mA; configured I/O drive strength = 2 mA; $2.4\text{ V} \leq V_{\text{DD}} < 3.6\text{ V}$	$V_{\text{DD}} \times 0.2$			V
		IL = 4 mA; configured I/O drive strength = 4 mA; $2.4\text{ V} \leq V_{\text{DD}} < 3.6\text{ V}$	$V_{\text{DD}} \times 0.2$			V
		IL = 8 mA; configured I/O drive strength = 8 mA; $2.4\text{ V} \leq V_{\text{DD}} < 3.6\text{ V}$	$V_{\text{DD}} \times 0.2$			V
		IL = 2 mA; configured I/O drive strength = 2 mA; $2.3\text{ V} \leq V_{\text{DD}} < 2.4\text{ V}$	$V_{\text{DD}} \times 0.25$			V
I_{OH}	High-level source current	2-mA drive		2		mA
		4-mA drive		4		
		6-mA drive		6		
I_{OL}	Low-level sink current	2-mA drive		2		mA
		4-mA drive		4		
		6-mA drive		6		
V_{IL}	nRESET ⁽²⁾		0.6			V

(1) TI recommends using the lowest possible drive strength that is adequate for the applications. This recommendation minimizes the risk of interference to the WLAN radio and reduces any potential degradation of RF sensitivity and performance. The default drive strength setting is 6 mA.

(2) The nRESET pin must be held below 0.6 V for the device to register a reset.

5.8 WLAN Receiver Characteristics

$T_A = 25^\circ\text{C}$, $V_{BAT} = 2.3$ to 3.6 V. Parameters measured at module pin on channel 6 (2437 MHz).

PARAMETER	RATE	MIN	TYP	MAX	UNIT
Sensitivity (8% PER for 11b rates, 10% PER for 11g or 11n rates) (10% PER) ⁽¹⁾	1 DSSS		-95.0		dBm
	2 DSSS		-93.0		
	11 CCK		-87.0		
	6 OFDM		-89.5		
	9 OFDM		-89.0		
	18 OFDM		-85.5		
	36 OFDM		-79.5		
	54 OFDM		-73.5		
	MCS7 (Mixed Mode)		-69.5		
Maximum input level (10% PER)	802.11b		-3.0		dBm
	802.11g		-9.0		

(1) Sensitivity is 1-dB worse on channel 13 (2472 MHz).

5.9 WLAN Transmitter Characteristics

$T_A = 25^\circ\text{C}$, $V_{BAT} = 2.3$ to 3.6 V. Parameters measured at module pin on 6 (2437 MHz)⁽¹⁾⁽²⁾.

PARAMETER	RATE	MIN	TYP	MAX	UNIT
Max RMS Output Power measured at 1 dB from IEEE spectral mask or EVM	1 DSSS		17.0		dBm
	2 DSSS		17.0		
	11 CCK		17.3		
	6 OFDM		16.3		
	9 OFDM		16.3		
	18 OFDM		16.0		
	36 OFDM		15.0		
	54 OFDM		13.5		
	MCS7 (Mixed Mode)		12		
Transmit center frequency accuracy		-20		20	ppm

(1) The edge channels (2412 MHz and 2462 MHz) have reduced TX power to meet FCC emission limits.

(2) Power of 802.11b rates are reduced to meet ETSI requirements.

5.10 Reset Requirement

PARAMETER	MIN	TYP	MAX	UNIT
V_{IH} Operation mode level		$0.65 \times V_{BAT}$		V
V_{IL} Shutdown mode level ⁽¹⁾	0	0.6		V
Minimum time for nReset low for resetting the module	5			ms
T_r and T_f Rise and fall times		20		μs

(1) The nRESET pin must be held below 0.6 V for the module to register a reset.

5.11 Thermal Resistance Characteristics for MOB Package

NAME	DESCRIPTION	$^\circ\text{C/W}$	AIR FLOW (m/s)
$R_{\theta JC}$	Junction-to-case	11.4	0.00
$R_{\theta JB}$	Junction-to-board	8.0	0.00
$R_{\theta JA}$	Junction-to-free air	18.7	0.00
Ψ_{sJT}	Junction-to-package top	5.3	0.00
Ψ_{sJB}	Junction-to-board	7.7	0.00

5.12 Timing and Switching Characteristics

5.12.1 Power-Up Sequencing

For proper start-up of the CC3120MOD module, perform the recommended power-up sequencing as follows:

1. Tie V_{BAT1} (pin 37) and V_{BAT2} (pin 40) together on the board.
2. Hold the nRESET pin low while the supplies are ramping up.

Figure 5-6 shows the reset timing diagram for the first-time power-up and reset removal.

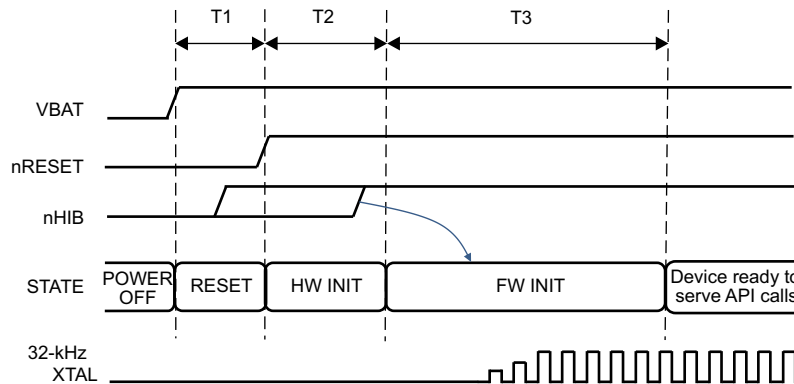

Figure 5-6. First-Time Power-Up and Reset Removal Timing Diagram

Table 5-2 describes the timing requirements for the first-time power-up and reset removal.

Table 5-2. First-Time Power-Up and Reset Removal Timing Requirements

ITEM	NAME	DESCRIPTION	MIN	TYP	MAX	UNIT
T1	Supply settling time	Depends on application board power supply, decoupling capacitor, and so on		3		ms
T2	Hardware wake-up time			25		ms
T3	Initialization time	Internal 32-kHz XTAL settling plus firmware initialization time plus radio calibration		1.35		s

5.12.2 Power-Down Sequencing

For proper power down of the CC3120MOD module, ensure that the nRESET (pin 35) and nHIB (pin 4) pins have remained in a known state for a minimum of 200 ms before removing power from the module.

5.12.3 Device Reset

When a device restart is required, the user may issue a negative pulse on either the nHIB pin (pin 4) or on the nRESET pin (pin 35), keeping the other pulled high, depending on the configuration of the platform. If the nRESET pin is used, the user must insure the following:

- A high-to-low reset pulse (on pin 35) of at least 200-ms duration

To ensure a proper reset sequence, the user must call the `sl_stop` function prior to toggling the reset.

5.12.4 Wakeup From HIBERNATE Mode Timing

Figure 5-7 shows the timing diagram for wakeup from HIBERNATE mode.

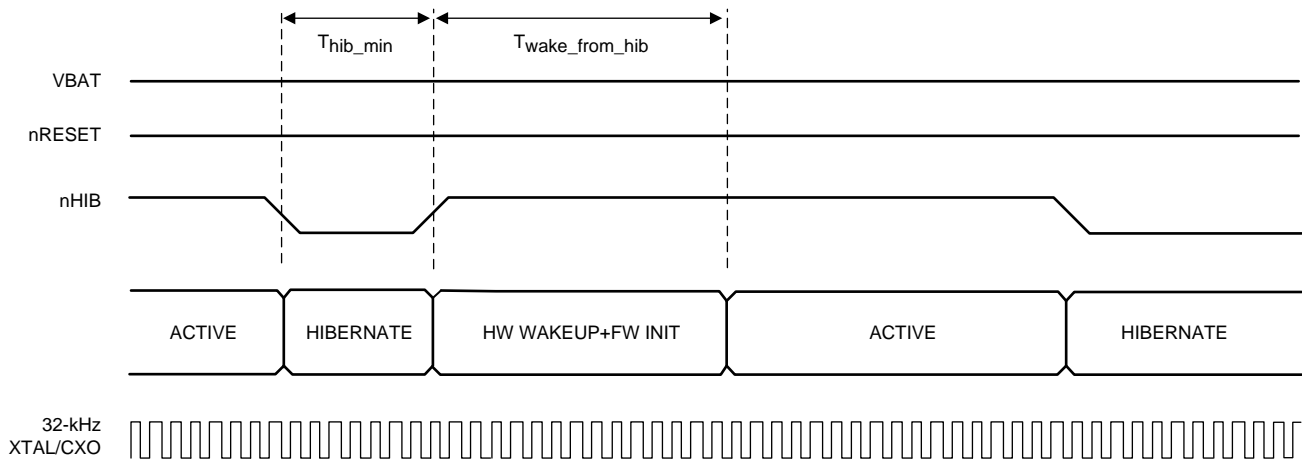

Figure 5-7. nHIB Timing Diagram

NOTE

The internal 32.768-kHz XTAL is kept enabled by default when the chip goes into HIBERNATE mode in response to nHIB being pulled low.

Table 5-3 describes the timing requirements for nHIB.

Table 5-3. nHIB Timing Requirements

ITEM	NAME	DESCRIPTION	MIN	TYP	MAX	UNIT
T _{hib_min}	Minimum hibernate time	Minimum pulse width of nHIB being low ⁽¹⁾	10			ms
T _{wake_from_hib}	Hardware wakeup time plus firmware initialization time	See ⁽²⁾		50		ms

- (1) If temperature changes by more than 20°C, initialization time from HIB can increase by 200 ms due to radio calibration.
- (2) Ensure that the nHIB pulse width is kept above the minimum requirement under all conditions (such as power up, MCU reset, and so on).

5.13 External Interfaces

This section describes the external interfaces supported by the CC3120MOD module, as follows:

- SPI Host
- Host UART
- External Flash

5.13.1 SPI Host Interface

The device interfaces to an external host using the SPI. The CC3120MOD module can interrupt the host using the HOST_INTR line to initiate the data transfer over the interface. The SPI host interface can work up to a speed of 20 MHz.

Figure 5-8 shows the SPI host interface.

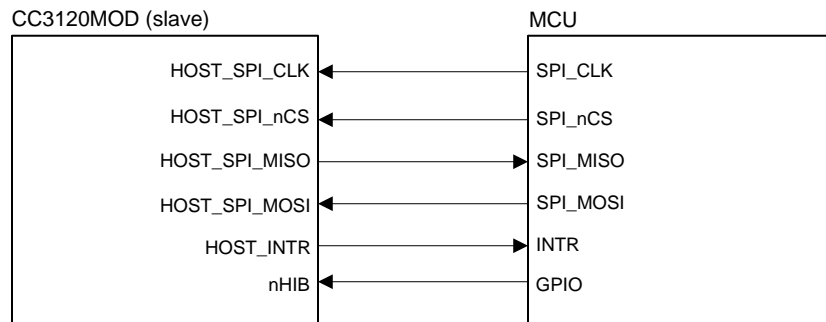

Figure 5-8. SPI Host Interface

Table 5-4 lists the SPI host interface pins.

Table 5-4. SPI Host Interface

PIN NAME	DESCRIPTION
HOST_SPI_CLK	Clock (up to 20 MHz) from MCU host to CC3120MOD module
HOST_SPI_nCS	CS (active low) signal from MCU host to CC3120MOD module
HOST_SPI_MOSI	Data from MCU host to CC3120MOD module
HOST_INTR	Interrupt from CC3120MOD module to MCU host
HOST_SPI_MISO	Data from CC3120MOD module to MCU host
nHIB	Active-low signal that commands the CC3120MOD module to enter hibernate mode (lowest power state)

Figure 5-9 shows the host SPI timing diagram.

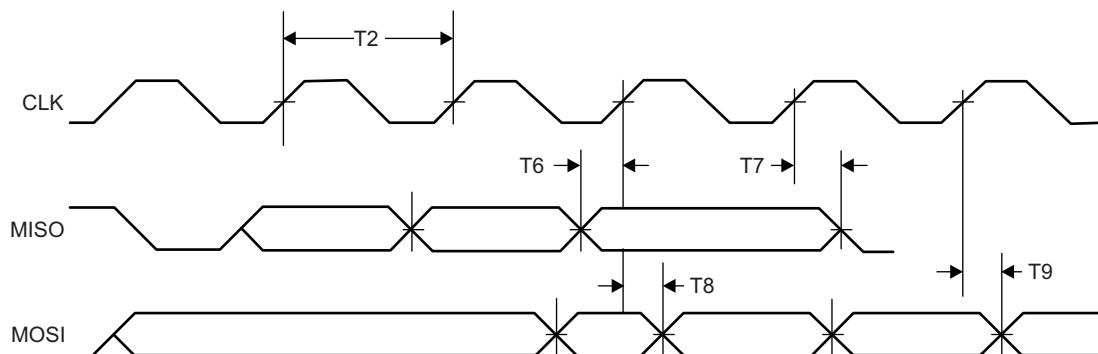

Figure 5-9. Host SPI Timing

Table 5-5 lists the host SPI timing parameters.

Table 5-5. Host SPI Timing Parameters

PARAMETER NUMBER	DESCRIPTION		MIN	MAX	UNIT
T1	F	Clock frequency at $V_{BAT} = 3.3\text{ V}$		20	MHz
		Clock frequency at $V_{BAT} = 2.3\text{ V}$		12	
T2	t_{clk}	Clock period	50		ns
T3	t_{LP}	Clock low period		25	ns
T4	t_{HT}	Clock high period		25	ns
T5	D	Duty cycle	45%	55%	
T6	t_{IS}	RX data setup time	4		ns
T7	t_{IH}	RX data hold time	4		ns
T8	t_{OD}	TX data output delay		20	ns
T9	t_{OH}	TX data hold time		24	ns

5.13.2 Host UART Interface

The SimpleLink device requires the UART configuration described in Table 5-6.

Table 5-6. SimpleLink™ UART Configuration

PROPERTY	SUPPORTED CC3120 CONFIGURATION
Baud rate	115200 bps, no auto-baud rate detection, can be changed by the host up to 3 Mbps using a special command
Data bits	8 bits
Flow control	CTS/RTS
Parity	None
Stop bits	1
Bit order	Least significant bit (LSB) first
Host interrupt polarity	Active high
Host interrupt mode	Rising edge or level 1
Endianness	Little-endian only ⁽¹⁾

(1) The SimpleLink device does not support automatic detection of the host length while using the UART interface.

5.13.2.1 5-Wire UART Topology

Figure 5-10 shows the typical 5-wire UART topology comprised of four standard UART lines plus one IRQ line from the device to the host controller to allow efficient low power mode.

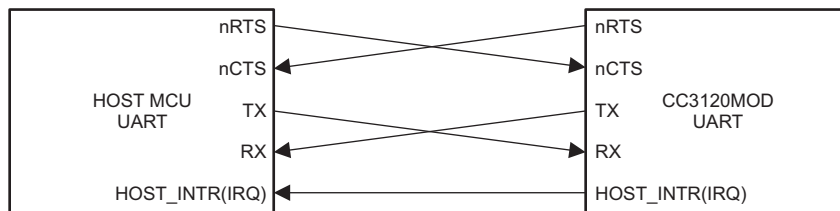

Figure 5-10. Typical 5-Wire UART Topology

Figure 5-10 shows the typical and recommended UART topology because it offers the maximum communication reliability and flexibility between the host and the SimpleLink device.

5.13.2.2 4-Wire UART Topology

The 4-wire UART topology eliminates the host IRQ line (see Figure 5-11). Using this topology requires one of the following conditions to be met:

- Host is always awake or active.
- Host goes to sleep, but the UART module has receiver start-edge detection for automatic wake up and does not lose data.

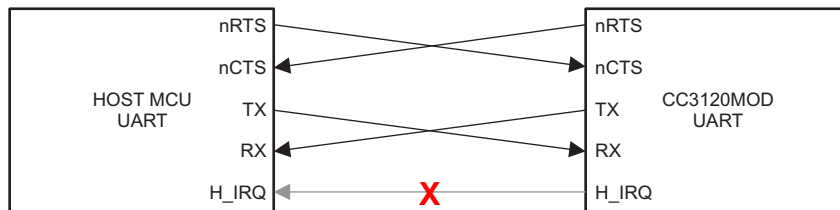

Figure 5-11. 4-Wire UART Configuration

5.13.2.3 3-Wire UART Topology

The 3-wire UART topology requires only the following lines (see Figure 5-12).

- RX
- TX
- nCTS

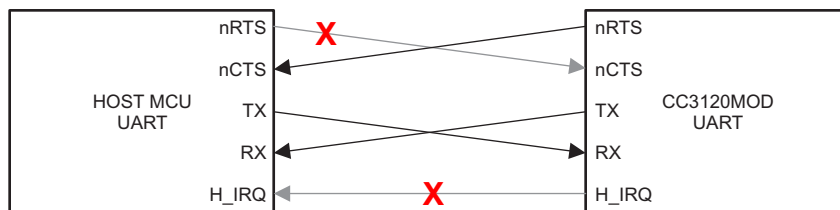

Figure 5-12. 3-Wire UART Topology

Using 3-wire topology requires one of the following conditions to be met:

- Host always stays awake or active.
- Host goes to sleep, but the UART module has receiver start-edge detection for auto wake up and does not lose data.
- Host can always receive any amount of data transmitted by the SimpleLink device because there is no flow control in this direction.

Because there is no full flow control, the host cannot stop the SimpleLink device to send its data; thus, the following parameters must be carefully considered:

- Maximum baud rate
- RX character interrupt latency and low-level driver jitter buffer
- Time consumed by the user's application

5.13.3 External Flash Interface

The CC120MOD module includes the Macronix 32-Mbit serial Flash. The serial Flash can be programmed directly via the external Flash interface (pins 13, 14, 15, and 17). Note that during normal operation, the external Flash interface should remain unconnected.

For timing details of the 32-Mbit Macronix serial Flash, see the [MX25R3235F](#) data sheet.

6 Detailed Description

6.1 Overview

The CC3120MOD Wi-Fi module contains a dedicated ARM MCU that offloads many of the networking activities from the host MCU. Including an 802.11 b/g/n radio, baseband, and MAC with a powerful crypto engine for a fast, secure WLAN and Internet connections with 256-bit encryption. The CC3120MOD module supports station, AP, and Wi-Fi Direct modes. The module also supports WPA2 personal and enterprise security and WPS 2.0. The Wi-Fi network processor includes an embedded IPv6 and IPv4 TCP/IP stack.

6.2 Module Features

6.2.1 WLAN

The WLAN features are as follows:

- 802.11 b/g/n integrated radio, modem, and MAC supporting WLAN communication as a BSS station, AP, and Wi-Fi Direct client and group owner with CCK and OFDM rates in the 2.4-GHz ISM band, channels 1 to 13.

NOTE

802.11n is supported only in Wi-Fi station, Wi-Fi direct, and P2P client modes.

- Autocalibrated radio with a single-ended 50-Ω interface enables easy connection to the antenna without requiring expertise in radio circuit design.
- Advanced connection manager with multiple user-configurable profiles stored in a serial Flash allows automatic, fast connection to an access point without user or host intervention.
- Supports all common Wi-Fi security modes for personal and enterprise networks, with on-chip security accelerators, including WEP, WPA/WPA2 PSK, and WPA2 Enterprise (802.1x).
- Smart provisioning options deeply integrated within the device provide a comprehensive end-to-end solution. Elaborate events notification to the host enable the application to control the provisioning decision flow. The wide variety of Wi-Fi provisioning methods include:
 - Access Point using HTTPS
 - SmartConfig Technology: a 1-step, 1-time process to connect a CC3120MOD-enabled module to the home wireless network, removing dependency on the I/O capabilities of the host MCU; thus, the device is usable by deeply embedded applications.
- 802.11 transceiver mode transmits and receives proprietary data through a socket without adding MAC or PHY headers, and provides the option to select the working channel, rate, and transmitted power. The receiver mode works together with the filtering options.

6.2.2 Network Stack

The network stack features are as follows:

- Integrated IPv4, IPv6, and TCP/IP stack with BSD socket APIs for simple Internet connectivity with any MCU, microprocessor, or ASIC

NOTE

Not all APIs are 100% BSD compliant. Not all BSD APIs are supported.

- Support of 16 simultaneous TCP, UDP, or RAW sockets
- Support of 6 simultaneous SSL/TLS sockets
- Built-in network protocols:
 - Static IP, LLA, DHCPv4, DHCPv6 (Stateful) with DAD and Stateless auto configuration
 - ARP, ICMPv4, IGMP, ICMPv6, MLD, ND
 - DNS client for easy connection to the local network and the Internet
- Built-in network application and utilities:
 - HTTP/HTTPS
 - Web page content stored on serial Flash
 - RESTful APIs for setting/configuring application content
 - Dynamic user callbacks
- Service discovery: Multicast DNS service discovery allows a client to advertise its service without a centralized server. After connecting to the access point, the CC3120 device provides critical information, such as device name, IP, vendor, and port number.
- DHCP server
- Ping

[Table 6-1](#) summarizes the NWP features.

Table 6-1. NWP Features

FEATURES	DESCRIPTION
Wi-Fi standards	802.11b/g/n station 802.11b/g AP supporting up to four stations Wi-Fi Direct client and group owner
Wi-Fi	Channels 1 to 13
Wi-Fi security	WEP, WPA/WPA2 PSK, WPA2 enterprise (802.1x)
Wi-Fi provisioning	SmartConfig technology, Wi-Fi protected setup (WPS2), AP mode with internal HTTP/HTTPS web server
IP protocols	IPv4 and IPv6
IP addressing	Static IP, LLA, DHCPv4, DHCPv6 (Stateful) with DAD and stateless auto configuration
Cross layer	ARP, ICMPv4, IGMP, ICMPv6, MLD, NDP
Transport	UDP, TCP SSLv3.0/TLSv1.0/TLSv1.1/TLSv1.2 RAW IP

Table 6-1. NWP Features (continued)

FEATURES	DESCRIPTION
Network applications and utilities	Ping HTTP/HTTPS web server mDNS DNS-SD DHCP server
Host interface	UART/SPI
Security	Secure file system Unique ID and private key for device authentication Crypto utilities Secure content delivery
Power management	Enhanced power policy management uses 802.11 power save and deep sleep power modes
Other	RF Transceiver Programmable RX Filters with Events trigger mechanism including WoWLAN Recovery mechanism – Restore to factory default

6.2.2.1 Security

The SimpleLink Wi-Fi CC3120MOD Internet-on-a-Chip module enhances the security capabilities available for development of IoT devices, while completely offloading these activities from the MCU to the networking subsystem. The security capabilities include the following key features:

Wi-Fi and Internet security

- Personal and enterprise Wi-Fi security
 - Personal standards
 - AES (WPA2-PSK)
 - TKIP (WPA-PSK)
 - WEP
- Enterprise standards
 - EAP Fast
 - EAP PEAPv0 MSCHAPv2
 - EAP PEAPv0 TLS
 - EAP PEAPv1 TLS EAP LS
 - EAP TTLS TLS
 - EAP TTLS MSCHAPv2

- **Secure sockets**
 - Protocol versions: SSL v3/TLS 1.0/TLS 1.1/TLS 1.2
 - On-chip powerful crypto engine for fast, secure Wi-Fi and internet connections with 256-bit AES encryption for TLS and SSL connections
 - Ciphers suites
 - SL_SEC_MASK_SSL_RSA_WITH_RC4_128_SHA
 - SL_SEC_MASK_SSL_RSA_WITH_RC4_128_MD5
 - SL_SEC_MASK_TLS_RSA_WITH_AES_256_CBC_SHA
 - SL_SEC_MASK_TLS_DHE_RSA_WITH_AES_256_CBC_SHA
 - SL_SEC_MASK_TLS_ECDHE_RSA_WITH_AES_256_CBC_SHA
 - SL_SEC_MASK_TLS_ECDHE_RSA_WITH_RC4_128_SHA
 - SL_SEC_MASK_TLS_RSA_WITH_AES_128_CBC_SHA256
 - SL_SEC_MASK_TLS_RSA_WITH_AES_256_CBC_SHA256
 - SL_SEC_MASK_TLS_ECDHE_RSA_WITH_AES_128_CBC_SHA256
 - SL_SEC_MASK_TLS_ECDHE_ECDSA_WITH_AES_128_CBC_SHA256
 - SL_SEC_MASK_TLS_ECDHE_ECDSA_WITH_AES_128_CBC_SHA
 - SL_SEC_MASK_TLS_ECDHE_ECDSA_WITH_AES_256_CBC_SHA
 - SL_SEC_MASK_TLS_RSA_WITH_AES_128_GCM_SHA256
 - SL_SEC_MASK_TLS_RSA_WITH_AES_256_GCM_SHA384
 - SL_SEC_MASK_TLS_DHE_RSA_WITH_AES_128_GCM_SHA256
 - SL_SEC_MASK_TLS_DHE_RSA_WITH_AES_256_GCM_SHA384
 - SL_SEC_MASK_TLS_ECDHE_RSA_WITH_AES_128_GCM_SHA256
 - SL_SEC_MASK_TLS_ECDHE_RSA_WITH_AES_256_GCM_SHA384
 - SL_SEC_MASK_TLS_ECDHE_ECDSA_WITH_AES_128_GCM_SHA256
 - SL_SEC_MASK_TLS_ECDHE_ECDSA_WITH_AES_256_GCM_SHA384
 - SL_SEC_MASK_TLS_ECDHE_ECDSA_WITH_CHACHA20_POLY1305_SHA256
 - SL_SEC_MASK_TLS_ECDHE_RSA_WITH_CHACHA20_POLY1305_SHA256
 - SL_SEC_MASK_TLS_DHE_RSA_WITH_CHACHA20_POLY1305_SHA256
 - Server authentication
 - Client authentication
 - Domain name verification
 - Socket upgrade to secure socket – STARTTLS
- Secure HTTP server (HTTPS)
- The trusted root-certificate catalog verifies that the CA used by the application is trusted and known secure content delivery.
- The TI root-of-trust public key is a hardware-based mechanism that allows authenticating TI as the genuine origin of a given content using asymmetric keys.
- Secure content delivery allows file transfer to the system in a secure way on any unsecured tunnel.
- **Code and data security**
 - Secured network information: Network passwords and certificates are encrypted
 - Secured and authenticated service pack: SP is signed based on TI certificate

6.2.3 Host Interface and Driver

- Interfaces over a 4-wire SPI with any MCU or a processor at a clock speed of 20 MHz
- Interfaces over UART with any MCU with a baud rate up to 3 Mbps. A low footprint driver is provided for TI MCUs and is easily ported to any processor or ASIC.
- Simple APIs enable easy integration with any single-threaded or multithreaded application.

6.2.4 System

- Connects directly to a battery
- Ultra-low leakage when disabled (hibernate mode) with a current of less than 5 μA with the RTC running and 1 μA when in shutdown mode.
- Integrated clock sources

6.3 Power-Management Subsystem

The CC3120MOD power-management subsystem contains DC-DC converters to accommodate the differing voltage or current requirements of the system.

The CC3120MOD is a fully integrated module-based WLAN radio solution used on an embedded system with a wide-voltage supply range. The internal power management, including DC-DC converters and LDOs, generates all of the voltages required for the module to operate from a wide variety of input sources. For maximum flexibility, the module can operate in the modes described in the following sections.

6.3.1 V_{BAT} Wide-Voltage Connection

In the wide-voltage battery connection, the module can be directly connected to two AA alkaline batteries. All other voltages required to operate the device are generated internally by the DC-DC converters. This scheme is the most common mode for the device because it supports wide-voltage operation from 2.3 to 3.6 V.

6.4 Low-Power Operating Modes

This section describes the low-power modes supported by the module to optimize battery life.

6.4.1 Low-Power Deep Sleep

The low-power deep-sleep (LPDS) mode is an energy-efficient and transparent sleep mode that is entered automatically during periods of inactivity based on internal power optimization algorithms. The module can wake up in less than 3 ms from the internal timer or from any incoming host command. Typical battery drain in this mode is 115 μA . During LPDS mode, the module retains the software state and certain configuration information. The operation is transparent to the external host; thus, no additional handshake is required to enter or exit this sleep mode.

6.4.2 Hibernate

The hibernate mode is the lowest power mode in which all of the digital logic is power-gated. Only a small section of the logic powered directly by the main input supply is retained. The real-time clock (RTC) is kept running and the module wakes up when the n_HIB line is asserted by the host driver. The typical battery drain in this mode is 5 μA . The wake-up time is longer than LPDS mode at about 50 ms.

6.4.3 Shutdown

Shutdown mode is the lowest power-mode system-wise. All device logics are off, including the realtime clock (RTC). The typical battery drain in this mode is 1 μA . The wake-up time in this mode is longer than hibernate at approximately 1.1 seconds.

6.5 Restoring Factory Default Configuration

The device has an internal recovery mechanism that allows rolling back the file system to its predefined factory image or restoring the factory default parameters of the device. The factory image is kept in a separate sector on the sFLASH in a secure manner and cannot be accessed from the host processor. The following restore modes are supported:

- None—no factory restore settings
- Enable restore of factory default parameters
- Enable restore of factory image and factory default parameters

The restore process is performed by pulling or forcing SOP[2:0] = 110 pins and toggling the nRESET pin from low to high.

The process is fail-safe and resumes operation if a power failure occurs before the restore is finished. The restore process typically takes about 8 seconds, depending on the attributes of the serial Flash vendor.

6.6 Device Certification and Qualification

The TI CC3120MOD module is certified for FCC, IC, ETSI/CE, Japan MIC, and SRRC. Moreover, the module is also Wi-Fi certified with the ability to request a certificate transfer for Wi-Fi alliance members. TI customers that build products based on the TI CC3120MOD can save in testing cost and time per product family.

The CC3120MOD module is certified to the standards listed in [Table 6-2](#) (with IDs where applicable):

Table 6-2. CC3120MOD List of Certifications

REGULATORY BODY	SPECIFICATION	ID (IF APPLICABLE)
FCC (USA)	Part 15C + MPE FCC RF Exposure	Z64-CC3120MOD
IC (Canada)	RSS-102 (MPE) and RSS-247 (Wi-Fi)	4511-CC3120MOD
ETSI/CE (Europe)	EN300328 v2.1.1 (2.4 GHz Wi-Fi)	—
	EN62311:2008 (MPE)	—
	EN301489-1 v2.1.1 (EMC General)	—
	EN301489-17 v3.1.1 (EMC Wi-Fi)	—
	EN60950-1:2006/A11:2009/A1:2010/A12:2011/A2:2013	—
Japan MIC	Article 49-20 of ORRE	210-170387
SRRC (China)	EN300328 v1.7.1	2017DJ2946(M)

6.6.1 FCC Certification and Statement

The TI CC3120MOD module is certified for FCC as a single-modular transmitter. The module is an FCC-certified radio module that carries a modular grant.

You are cautioned that changes or modifications not expressly approved by the part responsible for compliance could void the user's authority to operate the equipment.

This device complies with Part 15 of the FCC Rules. Operation is subject to the following two conditions:

- This device may not cause harmful interference.
- This device must accept any interference received, including interference that may cause undesired operation of the device.

CAUTION

FCC RF Radiation Exposure Statement:

This equipment complies with FCC radiation exposure limits set forth for an uncontrolled environment. End users must follow the specific operating instructions for satisfying RF exposure limits. This transmitter must not be colocated or operating with any other antenna or transmitter.

6.6.2 Industry Canada (IC) Certification and Statement

The TI CC3120MOD module is certified for IC as a single-modular transmitter. The TI CC3120MOD module meets IC modular approval and labeling requirements. The IC follows the same testing and rules as the FCC regarding certified modules in authorized equipment.

This device complies with Industry Canada licence-exempt RSS standards.

Operation is subject to the following two conditions:

- This device may not cause interference.
- This device must accept any interference, including interference that may cause undesired operation of the device.

Le présent appareil est conforme aux CNR d'Industrie Canada applicables aux appareils radio exempts de licence.

L'exploitation est autorisée aux deux conditions suivantes:

- L'appareil ne doit pas produire de brouillage
- L'utilisateur de l'appareil doit accepter tout brouillage radioélectrique subi, même si le brouillage est susceptible d'en compromettre le fonctionnement.

CAUTION

IC RF Radiation Exposure Statement:

To comply with IC RF exposure requirements, this device and its antenna must not be co-located or operating in conjunction with any other antenna or transmitter.

Pour se conformer aux exigences de conformité RF canadienne l'exposition, cet appareil et son antenne ne doivent pas être co-localisés ou fonctionnant en conjonction avec une autre antenne ou transmetteur.

6.6.3 ETSI/CE Certification

The TI CC3120MOD module is CE certified with certifications to the appropriate EU radio and EMC directives summarized in the Declaration of Conformity, evidenced by the CE mark. The module is tested against the new Radio Equipment Directive (RE-D). [See the full text of the EU Declaration of Conformity.](#)

6.6.4 Japan MIC Certification

The TI CC3120MOD module is MIC certified against article 49-20 and the relevant articles of the Ordinance Regulating Radio Equipment.

Operation is subject to the following condition:

- The HOST system does not contain a wireless wide area network (WWAN) device.

6.6.5 SRRC Certification and Statement

The TI CC3120MOD module complies with the SRRC's rules and regulations for a limited module approval (LMA).

Operation is subject to the following condition:

- The host system does not contain a WWAN device.

In addition, the host system using an approved LMA radio requires the following:

- New CMIIT ID
- Requires radiated-related testing only
- The host system's new SRRC certificate contains the LMA's CMIIT ID information
- The host system must be affixed with the new MIIT ID (not the LMA's CMIIT ID), following the SRRC labeling requirements.

NOTE

When an LMA radio is embedded into a host system, it does not mean the host system complies with SRRC rules and regulations. The manufacturer of the host system is responsible for ensuring that the combined system complies with SRRC rules and regulations.

6.7 Module Markings

Figure 6-1 shows the markings for the SimpleLink CC3120 Module.

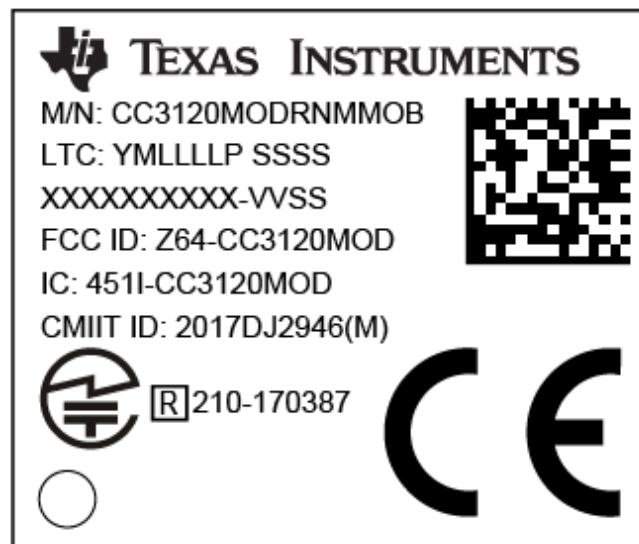



Figure 6-1. SimpleLink CC3120 Module Markings

Table 6-3 lists the SimpleLink module markings.

Table 6-3. Marking Descriptions

MARKING	DESCRIPTION
CC3120MODRNM MOB	Model
YMLLLLP SSSS	LTC (lot trace code): <ul style="list-style-type: none"> • Y = Year • M = Month • LLLL = Assembly lot code • P = Reserved for internal use • SSSS = Serial number
XXXXXXXXXX-VVSS	TI internal use only
Z64-CC3120MOD	FCC ID: single modular FCC grant ID
4511-CC3120MOD	IC: single modular IC grant ID
2017DJ2946(M)	CMIIT: limited modular SRRC grant ID
	MIC compliance mark
 210-170387	MIC ID: modular MIC grant ID
CE	CE compliance mark

6.8 End Product Labeling

This module is designed to comply with the FCC single modular FCC grant, FCC ID: Z64-CC3120MOD. The host system using this module must display a visible label indicating the following text:

Contains FCC ID: Z64-CC3120MOD

This module is designed to comply with the IC single modular IC grant, IC: 4511-CC3120MOD. The host system using this module must display a visible label indicating the following text:

Contains IC: 4511-CC3120MOD

This module is designed to comply with the JP statement, 201-170387. The host system using this module must display a visible label indicating the following text:

Contains transmitter module with certificate number: 201-170387.

6.9 Manual Information to the End User

The OEM integrator must be aware not to provide information to the end user regarding how to install or remove this RF module in the user's manual of the end product which integrates this module.

The end user manual must include all required regulatory information/warning as shown in this manual.

7 Applications, Implementation, and Layout

NOTE

Information in the following applications sections is not part of the TI component specification, and TI does not warrant its accuracy or completeness. TI's customers are responsible for determining suitability of components for their purposes. Customers should validate and test their design implementation to confirm system functionality.

7.1 Application Information

7.1.1 *Typical Application*

[Figure 7-1](#) shows the typical application schematic using the CC3120MOD module. For a full operation reference design, see the [BoosterPack](#) that uses the CC3120MOD module.

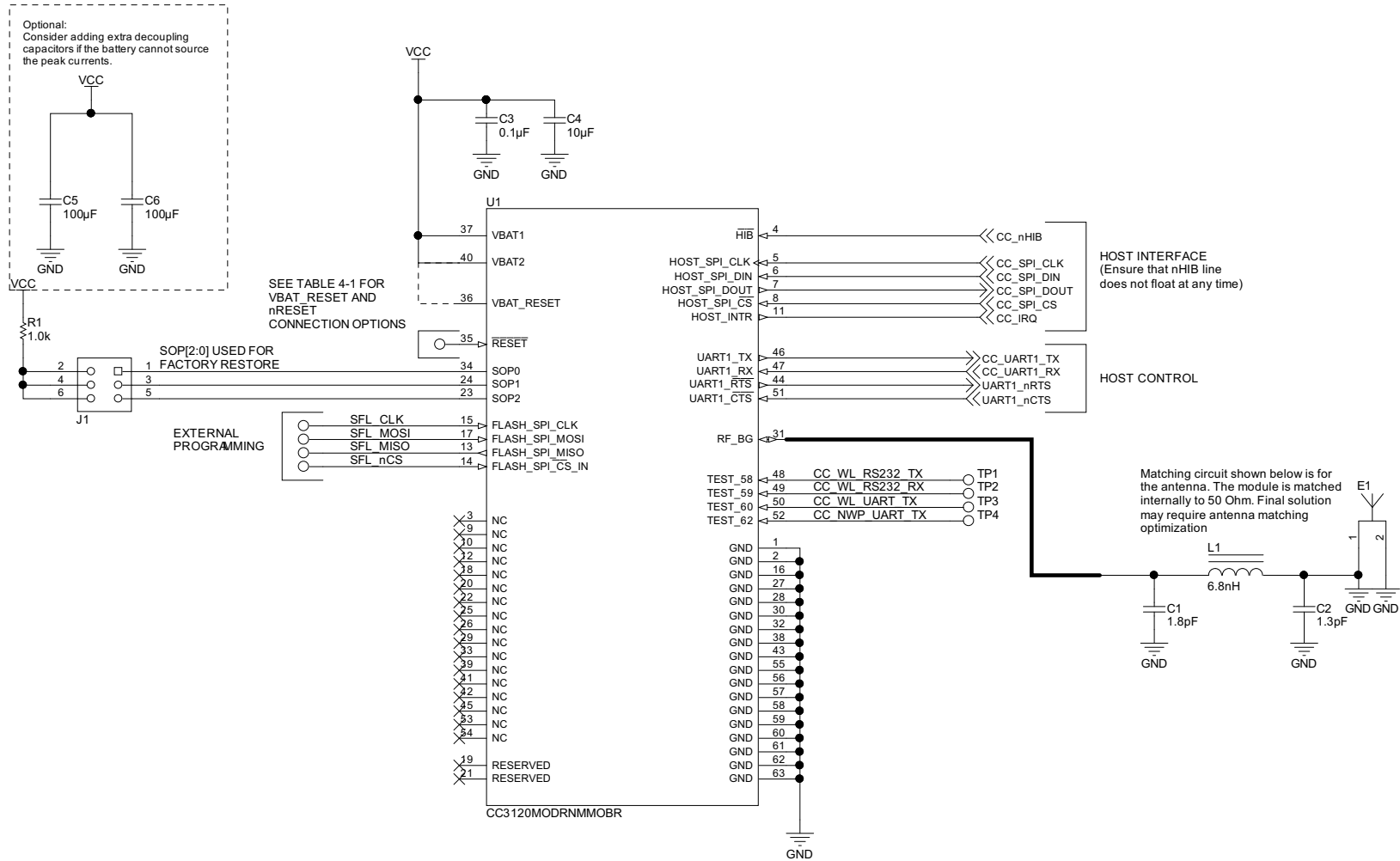

Note: This is the reference schematic and not an actual board design. For the board files and BOM, refer to the CC3120MODBOOST in the [CC3120MOD Tools Folder](#).

Figure 7-1. CC3120MOD Module Reference Schematic

Table 7-1 lists the bill of materials for a typical application using the CC3120MOD module shown in Figure 7-1.

Table 7-1. Bill of Materials

QUANTITY	DESIGNATOR	VALUE	MANUFACTURER	PART NUMBER	DESCRIPTION
1	C1	1.8 pF	MuRata	GCM1555C1H1R8BA16	CAP, CERM, 1.8 pF, 50 V, ±0.1 pF, C0G/NP0, 0402
1	C2	1.3 pF	MuRata	GCM1555C1H1R3BA16	CAP, CERM, 1.3 pF, 50 V, ±5%, C0G/NP0, 0402
1	C3	0.1 µF	MuRata	GRM155R60J104KA01D	CAP, CERM, 0.1 µF, 6.3 V, ±10%, X5R, 0402
1	C4	10 µF	MuRata	GRM21BR61A106KE19L	CAP, CERM, 10 µF, 10 V, ±10%, X5R, 0805
2	C5, C6	100 µF	MuRata	GRM31CR60J107ME39L	CAP, CERM, 100 µF, 6.3 V, ±20%, X5R, 1206
1	E1	2.45-GHz Ant	Taiyo Yuden	AH316M245001-T	ANT BLUETOOTH W-LAN ZIGBEE WIMAX, SMD
1	L1	6.8 nH	MuRata	LQP15MN6N8B02	6.8 nH Unshielded Thin Film Inductor 130 mA 900 mΩ Max 0402
1	R1	1.0 k	Vishay-Dale	CRCW04021K00JNED	RES, 1.0 k, 5%, 0.063 W, 0402
1	U1	CC3120MOD	Texas Instruments	CC3120MODRNMMOBR	SimpleLink Certified Wi-Fi Network Processor Internet-of-Things Module Solution for MCU Applications, MOB0063A (SIP MODULE-63)

7.1.2 Power Supply Decoupling and Bulk Capacitors

Depending upon routing resistors and battery type, TI recommends adding two 100- μ F ceramic capacitors to help provide the peak current drawn by the CC3120MOD module.

NOTE

The module enters a brown-out condition whenever the input voltage dips below V_{BROWN} (see [Figure 5-4](#) and [Figure 5-5](#)). This condition must be considered during design of the power supply routing specifically if operating from a battery. For more details on brown-out consideration, see [Section 5.6](#).

7.1.3 Reset

The module features an internal RC circuit to reset the device during power ON. The nRESET pin must be held below 0.6 V for at least 5 ms for the device to successfully reset.

7.1.4 Unused Pins

All unused pins can be left unconnected without any concern to leakage current.

7.2 PCB Layout Guidelines

This section details the PCB guidelines to speed up the PCB design using the CC3120MOD Module. The integrator of the CC3120MOD module must comply with the PCB layout recommendations described in the following subsections to preserve/minimize the risk with regulatory certifications for FCC, IC, CE, MIC, and SRRC. Moreover, TI recommends customers follow the guidelines described in this section to achieve similar performance to that obtained with the TI reference design.

7.2.1 General Layout Recommendations

Ensure that the following general layout recommendations are followed:

- Have a solid ground plane and ground vias under the module for stable system and thermal dissipation.
- Do **not** run signal traces underneath the module on a layer where the module is mounted.
- RF traces must have 50- Ω impedance.
- RF trace bends must be made with gradual curves, and 90 degree bends must be avoided.
- RF traces must **not** have sharp corners.
- There must be no traces or ground under the antenna section.
- RF traces must have via stitching on the ground plane beside the RF trace on both sides.
- RF traces must be as short as possible. The antenna, RF traces, and the module must be on the edge of the PCB product in consideration of the product enclosure material and proximity.

7.2.2 RF Layout Recommendations

The RF section of this wireless device gets top priority in terms of layout. It is very important for the RF section to be laid out correctly to ensure optimum performance from the device. A poor layout can cause low-output power, EVM degradation, sensitivity degradation, and mask violations.

Figure 7-2 shows the RF placement and routing of the CC3120MOD module.

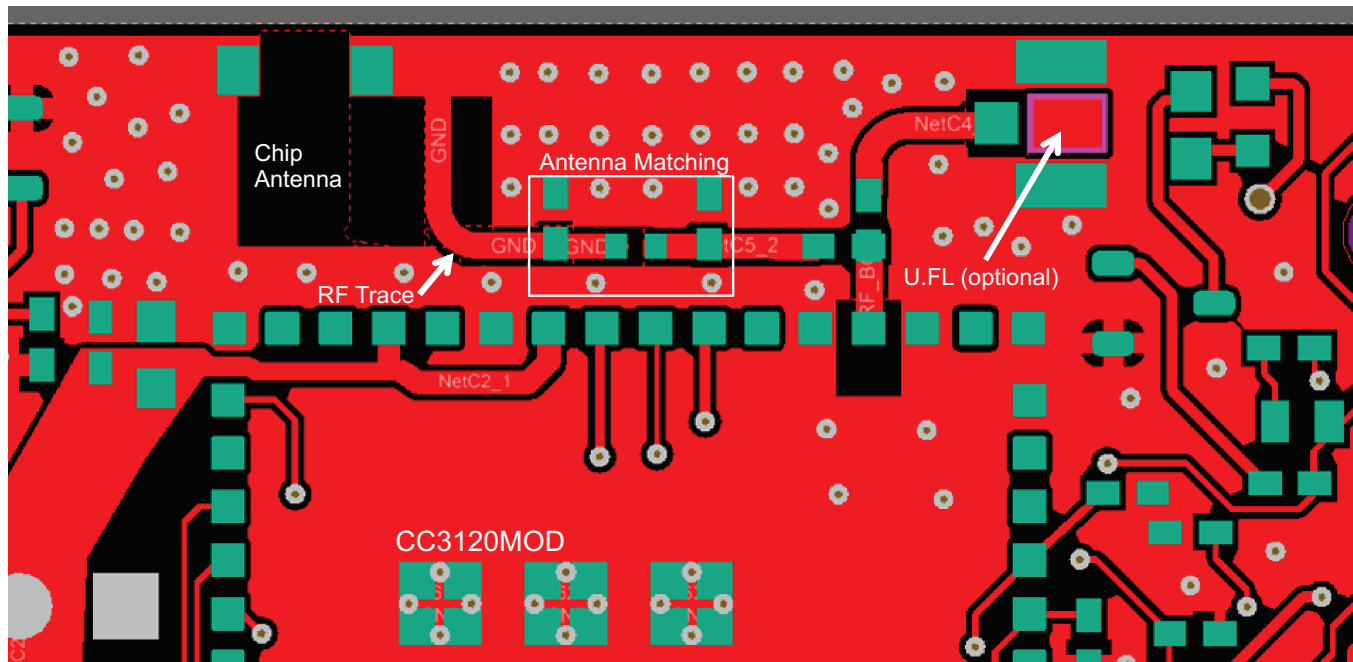

Figure 7-2. RF Section Layout

For optimal RF performance, ensure the copper cut out on the top layer under the RF-BG pin, (pin 31), is as shown in [Figure 7-3](#).

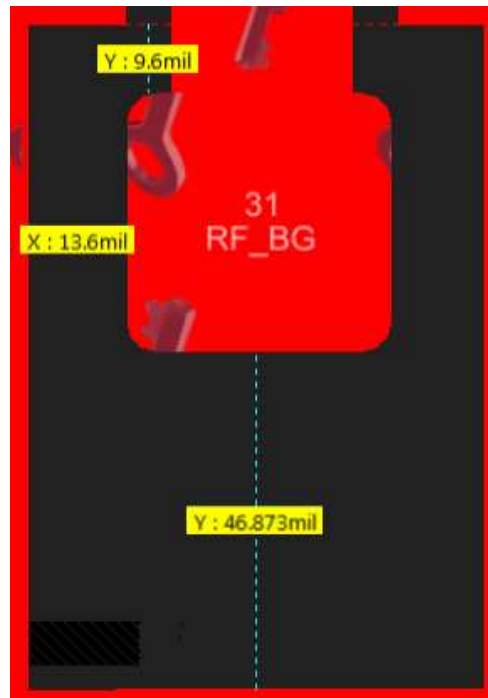

Figure 7-3. Top Layer Copper Pull Back on RF Pads

7.2.3 Antenna Placement and Routing

The antenna is the element used to convert the guided waves on the PCB traces to the free space electromagnetic radiation. The placement and layout of the antenna are the keys to increased range and data rates. [Table 7-2](#) provides a summary of the recommended antennas to use with the CC3120MOD module.

Table 7-2. Antenna Guidelines

SR NO.	GUIDELINES
1	Place the antenna on an edge or corner of the PCB.
2	Ensure that no signals are routed across the antenna elements on all the layers of the PCB.
3	Most antennas, including the chip antenna used on the booster pack, require ground clearance on all the layers of the PCB. Ensure that the ground is cleared on inner layers as well.
4	Ensure that there is provision to place matching components for the antenna. These must be tuned for best return loss when the complete board is assembled. Any plastics or casing must also be mounted while tuning the antenna because this can impact the impedance.
5	Ensure that the antenna impedance is 50 Ω because the device is rated to work only with a 50- Ω system.
6	In case of printed antenna, ensure that the simulation is performed with the solder mask in consideration.
7	Ensure that the antenna has a near omni-directional pattern.
8	The feed point of the antenna is required to be grounded. This is only for the antenna type used on the CC3120MOD BoosterPack. Refer to the specific antenna data sheets for the recommendations.
9	To use the FCC certification of the module, see the CC3120 and CC3220 Radio Certifications wiki page on CC3120 Radio certification

[Table 7-3](#) lists the recommended antennas to use with the CC3120MOD module. Other antennas may be available for use with the CC3120MOD module. See the [CC3120 and CC3220 Radio Certifications](#) wiki page.

Table 7-3. Recommended Components

CHOICE	PART NUMBER	MANUFACTURER	NOTES
1	AH316M245001-T	Taiyo Yuden	Can be placed at the edge of the PCB using the least amount of PCB area.

7.2.4 Transmission Line Considerations

The RF signal from the device is routed to the antenna using a Coplanar Waveguide with ground (CPW-G) structure. CPW-G structure offers the maximum amount of isolation and the best possible shielding to the RF lines. In addition to the ground on the L1 layer, placing GND vias along the line also provides additional shielding. Figure 7-4 shows a cross section of the coplanar waveguide with the critical dimensions.

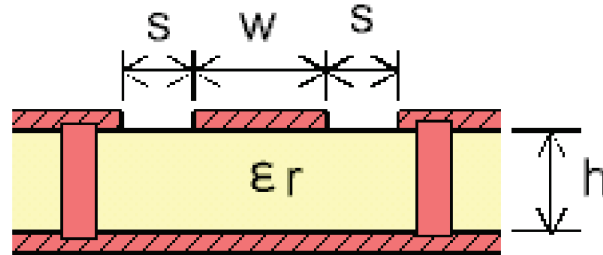

Figure 7-4. Coplanar Waveguide (Cross Section)

Figure 7-5 shows the top view of the coplanar waveguide with GND and via stitching.

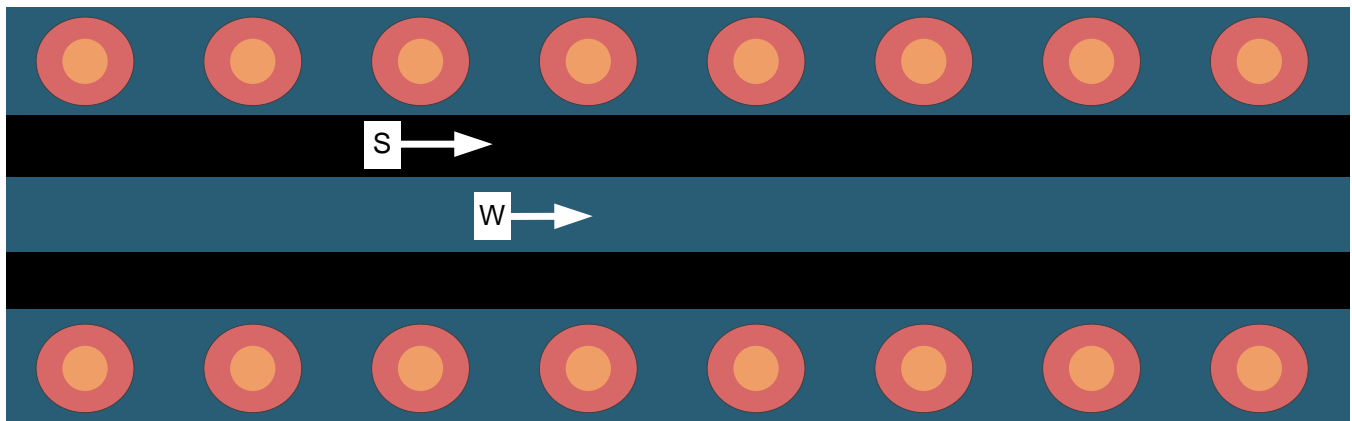

Figure 7-5. CPW With GND and Via Stitching (Top View)

The recommended values for the PCB are provided for 2-layer boards in [Table 7-4](#) and 4-layer boards in [Table 7-5](#).

Table 7-4. Recommended PCB Values for 2-Layer Board (L1 to L2 = 42.1 mils)

PARAMETER	VALUE	UNIT
W	24.5	mils
S	6.5	mils
H	42.1	mils
Er (FR-4 substrate)	4.8	

Table 7-5. Recommended PCB Values for 4-Layer Board (L1 to L2 = 16 mils)

PARAMETER	VALUE	UNITS
W	21	mils
S	10	mils
H	16	mils
Er (FR-4 substrate)	4.5	

8 Environmental Requirements and Specifications

8.1 Temperature

8.1.1 PCB Bending

The PCB bending specification will maintain planeness at a thickness of less than 0.1 mm.

8.2 Handling Environment

8.2.1 Terminals

The product is mounted with motherboard through land-grid array (LGA). To prevent poor soldering, do not touch the LGA portion by hand.

8.2.2 Falling

The mounted components will be damaged if the product falls or is dropped. Such damage may cause the product to malfunction.

8.3 Storage Condition

8.3.1 Moisture Barrier Bag Before Opened

A moisture barrier bag must be stored in a temperature of less than 30°C with humidity under 85% RH. The calculated shelf life for the dry-packed product will be 12 months from the date the bag is sealed.

8.3.2 Moisture Barrier Bag Open

Humidity indicator cards must be blue, < 30%.

8.4 Baking Conditions

Products require baking before mounting if:

- Humidity indicator cards read > 30%
- Temp < 30°C, humidity < 70% RH, over 96 hours

Baking condition: 90°C, 12–24 hours

Baking times: 1 time

8.5 Soldering and Reflow Condition

- Heating method: Conventional convection or IR convection
- Temperature measurement: Thermocouple $d = 0.1 \text{ mm}$ to 0.2 mm CA (K) or CC (T) at soldering portion or equivalent method
- Solder paste composition: Sn/3.0 Ag/0.5 Cu
- Allowable reflow soldering times: 2 times based on the reflow soldering profile (see [Figure 8-1](#))
- Temperature profile: Reflow soldering will be done according to the temperature profile (see [Figure 8-1](#))
- Peak temp: 245°C

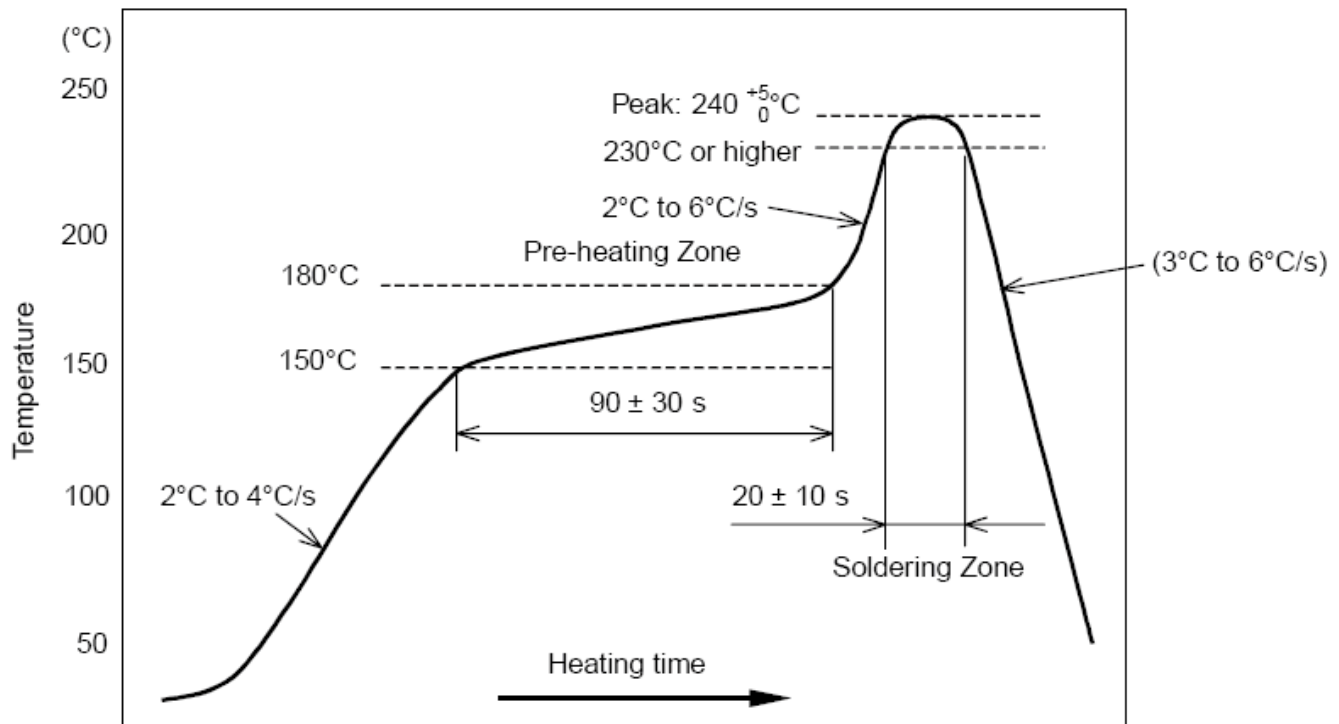

Figure 8-1. Temperature Profile for Evaluation of Solder Heat Resistance of a Component (at Solder Joint)

NOTE

TI does not recommend the use of conformal coating or similar material on the SimpleLink module. This coating can lead to localized stress on the WCSP solder connections inside the module and impact the device reliability. Use caution during the module assembly process to the final PCB to avoid the presence of foreign material inside the module.

9 Device and Documentation Support

TI offers an extensive line of development tools. Tools and software to evaluate the performance of the device, generate code, and develop solutions are listed in this section.

9.1 Device Nomenclature

To designate the stages in the product development cycle, TI assigns prefixes to the part numbers of the CC3120MOD and support tools (see [Figure 9-1](#)).

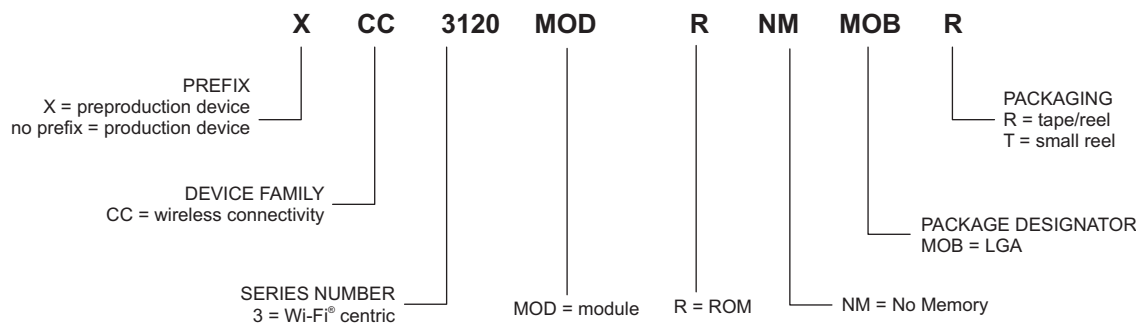

Figure 9-1. CC3120MOD Module Nomenclature

For orderable part numbers of CC3120MOD modules in the MOB package types, see the Package Option Addendum of this document, the TI website (www.ti.com), or contact your TI sales representative.

9.2 Development Tools and Software

For the most up-to-date list of development tools and software, visit the [CC3120MOD tools and software](#) page. You can also click on the Alert me button in the top-right corner of the page to stay informed about updates related to the CC3120MOD.

SimpleLink™ Wi-Fi® Starter Pro The SimpleLink™ Wi-Fi® Starter Pro mobile application is a new mobile app for SimpleLink provisioning. It goes with the embedded provisioning library and example that runs on the device side. The new provisioning release is TI's recommendation for Wi-Fi provisioning using SimpleLink Wi-Fi products. It implements advanced AP mode provisioning with feedback and fallback options to ensure a successful process has been accomplished. Customers can use both the embedded library and the mobile library for integration into their end products.

SimpleLink™ Wi-Fi® CC3120 SDK Plugin The CC3120 SDK contains drivers, many sample applications for Wi-Fi features and internet, and documentation needed to use the CC3120 Internet-on-a-chip™ solution. This SDK can be used with TI's MSP432P401R LaunchPad™, or SimpleLink Studio, a PC tool that allows MCU development with the CC3120. You can also use the SDK as example code for any platform. All sample applications in the SDK are supported on TI's MSP432P401R ultra-low-power MCUs with Code Composer Studio™ IDE and TI RTOS. In addition, many of the applications support IAR.

SimpleLink™ Studio for CC31xx SimpleLink™ Studio for CC31xx is a Windows®-based software tool used to aid in the development of embedded networking applications and software for microcontrollers. Using SimpleLink Studio for CC31xx, embedded software developers can develop and test applications using any desktop IDE, such as Visual Studio or Eclipse, and connect their applications to the cloud using the CC31xx BoosterPack™. The application can then be easily ported to any microcontroller. With the SimpleLink Wi-Fi CC31xx solution, customers now have the flexibility to add Wi-Fi to any microcontroller (MCU). This Internet-on-a-chip solution contains all you need to easily create IoT solutions – security, quick connection, cloud support and more. For more information on CC31xx devices, visit <http://www.ti.com/simplelinkwifi>.

SimpleLink™ Wi-Fi® Radio Testing Tool The SimpleLink™ Wi-Fi® Radio Testing Tool is a Windows-based software tool for RF evaluation and testing of SimpleLink Wi-Fi CC3120 and CC3220 designs during development and certification. The tool enables low-level radio testing capabilities by manually setting the radio into transmit or receive modes. Use of the tool requires familiarity and knowledge of radio circuit theory and radio test methods.

Uniflash Standalone Flash Tool for TI Microcontrollers (MCU), Sitara Processors and SimpleLink Devices CCS Uniflash is a standalone tool used to program onchip flash memory on TI MCUs and onboard flash memory for Sitara processors. Uniflash has a GUI, command line, and scripting interface. CCS Uniflash is available free of charge.

9.3 Firmware Updates

TI updates features in the service pack for this module with no published schedule. Due to the ongoing changes, TI recommends that users have the latest service pack in their module for production.

To stay informed, sign up with the SDK Alert me button in the top-right corner of the product page or visit [here](#).

9.4 Documentation Support

To receive notification of documentation updates — including silicon errata — go to the CC3120MOD product folder on ti.com, and click the Alert me button in the upper-right corner. This registers you to receive a weekly digest of updated product information (if any). For change details, check the revision history of any revised document. The current documentation which describes the processor, related peripherals, and other technical collateral follows. The following documents provide support for the CC3120MOD module.

Application Reports

[Transfer of TI's Wi-Fi® Alliance Certifications to Products Based on SimpleLink™](#) This document explains how to employ the Wi-Fi® Alliance (WFA) derivative certification transfer policy to transfer a WFA certification, already obtained by Texas Instruments, to a system you have developed.

[SimpleLink™ CC3x20 Wi-Fi® Internet-on-a chip™ Solution Built-In Security Features](#) The SimpleLink Wi-Fi CC3120 and CC3220 Internet-on-a chip family of devices from Texas Instruments offers a wide range of built-in security features to help developers address a variety of security needs, which is achieved without any processing burden on the main MCU. This document describes these security-related features and provides recommendations for leveraging each feature in the context of practical system implementation.

[Using Serial Flash on SimpleLink™ CC3x20 Wi-Fi® and Internet-of-Things Devices](#) This application note is divided into two parts. The first part provides important guidelines and best practice design techniques to consider when choosing and embedding a serial flash paired with the CC3120 and CC3220 (CC3x20) devices. The second part describes the file system, along with guidelines and considerations for system designers working with the CC3x20 devices.

[SimpleLink™ CC3x20 Wi-Fi® and Internet of Things Over-the-Air Update](#) This document describes the OTA library for the SimpleLink™ Wi-Fi® CC3x20 family of devices from Texas Instruments and explains how to prepare a new cloud-ready update to be downloaded by the OTA library.

[SimpleLink™ CC3x20 Wi-Fi® Internet-on-a chip™ Solution Device Provisioning](#) This guide describes the provisioning process, which provides the SimpleLink Wi-Fi device with the information (network name, password, and so forth) needed to connect to a wireless network.

[SimpleLink™ CC3x20 Wi-Fi® Internet-on-a chip™ Networking Subsystem Power Management](#) This application report describes the best practices for power management and extended battery life for embedded low-power Wi-Fi devices such as the SimpleLink Wi-Fi Internet-on-a chip™ solution from Texas Instruments™.

User's Guides

[SimpleLink™ CC3x20 Wi-Fi® Embedded Programming](#) This application note describes in detail additional options that leverage all the features UniFlash has to offer, but without the necessary connected PC. This option is referred to as Embedded Programming. To achieve embedded programming, bootloader protocol implemented over UART is described in detail.

[UniFlash SimpleLink™ CC3x20 Wi-Fi® and IoC™ Solution ImageCreator and Pro](#) This document describes the installation, operation, and usage of the SimpleLink ImageCreator tool as part of the UniFlash.

[SimpleLink™ CC3x20 Wi-Fi® and Internet of Things Network Processor](#) This document provides software (SW) programmers with all of the required knowledge for working with the networking subsystem of the SimpleLink Wi-Fi devices. This guide provides basic guidelines for writing robust, optimized networking host applications, and describes the capabilities of the networking subsystem. The guide contains some example code snapshots, to give users an idea of how to work with the host driver. More comprehensive code examples can be found in the formal software development kit (SDK). This guide does not provide a detailed description of the host driver APIs.

[SimpleLink™ CC3x20 Wi-Fi® Provisioning for Mobile Applications](#) This guide describes TI's SimpleLink™ Wi-Fi® provisioning solution for mobile applications, specifically on the usage of the Android™ and iOS® building blocks for UI requirements, networking, and provisioning APIs required for building the mobile application.

[SimpleLink™ CC3120 Wi-Fi® Internet-on-a-chip™ Solution SDK](#) This guide is intended to help users in the initial setup and demonstration of the different demos in the CC3120 SDK. The guide lists the software and hardware components required to get started, and explains how to install the supported integrated development environment (IDE), SimpleLink CC3120 SDK, and the various other tools required.

[SimpleLink™ CC3x20 Wi-Fi® and Internet-on-a-chip™ Solution Radio Tool](#) The Radio Tool serves as a control panel for direct access to the radio, and can be used for both the radio frequency (RF) evaluation and for certification purposes. This guide describes how to have the tool work seamlessly on Texas Instruments™ evaluation platforms such as the BoosterPack™ plus FTDI emulation board for CC3120 devices, and the LaunchPad™ for CC3220 devices.

[SimpleLink™ CC3120 Wi-Fi® BoosterPack™ Plug-In Module and IoT Solution](#) The SimpleLink Wi-Fi CC3120 wireless network processor from Texas Instruments™ provides users the flexibility to add Wi-Fi to any MCU. This user's guide explains the various configurations of the CC3120 BoosterPack™ Plug-In Module.

More Literature

[RemoTI Manifest](#)

Design Files

[SimpleLink™ CC3120MOD Wi-Fi® and Internet of Things CC3120 Hardware](#)

[SimpleLink™ CC3x20 Wi-Fi® and Internet of Things](#)

9.4.1 Community Resources

The following links connect to TI community resources. Linked contents are provided "AS IS" by the respective contributors. They do not constitute TI specifications and do not necessarily reflect TI's views; see TI's [Terms of Use](#).

TI E2E™ Online Community The TI engineer-to-engineer (E2E) community was created to foster collaboration among engineers. At e2e.ti.com, you can ask questions, share knowledge, explore ideas and help solve problems with fellow engineers.

TI Embedded Processors Wiki Established to help developers get started with Embedded Processors from Texas Instruments and to foster innovation and growth of general knowledge about the hardware and software surrounding these devices.

9.5 Trademarks

Internet-on-a chip, SimpleLink, SmartConfig, E2E, Internet-on-a-chip, LaunchPad, Code Composer Studio, BoosterPack are trademarks of Texas Instruments.

ARM is a registered trademark of ARM Limited.

Cortex, M4 are registered trademarks of ARM.

Bluetooth is a registered trademark of Bluetooth SIG Inc.

Wi-Fi CERTIFIED is a trademark of Wi-Fi Alliance.

Wi-Fi, Wi-Fi Direct are registered trademarks of Wi-Fi Alliance.

9.6 Electrostatic Discharge Caution



This integrated circuit can be damaged by ESD. Texas Instruments recommends that all integrated circuits be handled with appropriate precautions. Failure to observe proper handling and installation procedures can cause damage.

ESD damage can range from subtle performance degradation to complete device failure. Precision integrated circuits may be more susceptible to damage because very small parametric changes could cause the device not to meet its published specifications.

9.7 Export Control Notice

Recipient agrees to not knowingly export or re-export, directly or indirectly, any product or technical data (as defined by the U.S., EU, and other Export Administration Regulations) including software, or any controlled product restricted by other applicable national regulations, received from disclosing party under nondisclosure obligations (if any), or any direct product of such technology, to any destination to which such export or re-export is restricted or prohibited by U.S. or other applicable laws, without obtaining prior authorization from U.S. Department of Commerce and other competent Government authorities to the extent required by those laws.

9.8 Glossary

TI Glossary This glossary lists and explains terms, acronyms, and definitions.

10 Mechanical, Packaging, and Orderable Information

The following pages include mechanical packaging and orderable information. This information is the most current data available for the designated devices. This data is subject to change without notice and revision of this document.

10.1 Mechanical, Land, and Solder Paste Drawings

NOTE

1. The total height of the module is 2.45 mm.
 2. The weight of the module is 0.00175 kg \pm 3%.
-

NOTE

1. All dimensions are in mm.
 2. Solder mask should be the same or 5% larger than the dimension of the pad
 3. Solder paste must be the same as the pin for all peripheral pads. For ground pins, make the solder paste 20% smaller than the pad.
-

10.2 Package Option Addendum

The CC3120MOD is only offered in a 1000-unit real option.

10.2.1 Packaging Information

Orderable Device	Status ⁽¹⁾	Package Type	Package Drawing	Pins	Package Qty	Eco Plan ⁽²⁾	Lead/Ball Finish	MSL Peak Temp ⁽³⁾	Op Temp (°C)	Device Marking ⁽⁴⁾ ⁽⁵⁾
CC3120MODRNMMOBR	ACTIVE	LGA	MOB	63	1000	Green (RoHS and no Sb/Br)	Ni Au	3, 250°C	-40 to 85	CC3120MODRNMMOB

- (1) The marketing status values are defined as follows:
ACTIVE: Product device recommended for new designs.
LIFEBUY: TI has announced that the device will be discontinued, and a lifetime-buy period is in effect.
NRND: Not recommended for new designs. Device is in production to support existing customers, but TI does not recommend using this part in a new design.
PRE_PROD Unannounced device, not in production, not available for mass market, nor on the web, samples not available.
PREVIEW: Device has been announced but is not in production. Samples may or may not be available.
OBSOLETE: TI has discontinued the production of the device.
- (2) Eco Plan - The planned eco-friendly classification: Pb-Free (RoHS), Pb-Free (RoHS Exempt), or Green (RoHS & no Sb/Br) - please check <http://www.ti.com/productcontent> for the latest availability information and additional product content details.
TBD: The Pb-Free/Green conversion plan has not been defined.
Pb-Free (RoHS): TI's terms "Lead-Free" or "Pb-Free" mean semiconductor products that are compatible with the current RoHS requirements for all 6 substances, including the requirement that lead not exceed 0.1% by weight in homogeneous materials. Where designed to be soldered at high temperatures, TI Pb-Free products are suitable for use in specified lead-free processes.
Pb-Free (RoHS Exempt): This component has a RoHS exemption for either 1) lead-based flip-chip solder bumps used between the die and package, or 2) lead-based die adhesive used between the die and leadframe. The component is otherwise considered Pb-Free (RoHS compatible) as defined above.
Green (RoHS & no Sb/Br): TI defines "Green" to mean Pb-Free (RoHS compatible), and free of Bromine (Br) and Antimony (Sb) based flame retardants (Br or Sb do not exceed 0.1% by weight in homogeneous material)
- (3) MSL, Peak Temp. -- The Moisture Sensitivity Level rating according to the JEDEC industry standard classifications, and peak solder temperature.
- (4) There may be additional marking, which relates to the logo, the lot trace code information, or the environmental category on the device
- (5) Multiple Device markings will be inside parentheses. Only on Device Marking contained in parentheses and separated by a "~" will appear on a device. If a line is indented then it is a continuation of the previous line and the two combined represent the entire Device Marking for that device.

Important Information and Disclaimer: The information provided on this page represents TI's knowledge and belief as of the date that it is provided. TI bases its knowledge and belief on information provided by third parties, and makes no representation or warranty as to the accuracy of such information. Efforts are underway to better integrate information from third parties. TI has taken and continues to take reasonable steps to provide representative and accurate information but may not have conducted destructive testing or chemical analysis on incoming materials and chemicals. TI and TI suppliers consider certain information to be proprietary, and thus CAS numbers and other limited information may not be available for release. In no event shall TI's liability arising out of such information exceed the total purchase price of the TI part(s) at issue in this document sold by TI to Customer on an annual basis.

10.3 Tape and Reel Information

Emboss taping specification for MOC 1000 pin.

10.3.1 Tape and Reel Specification

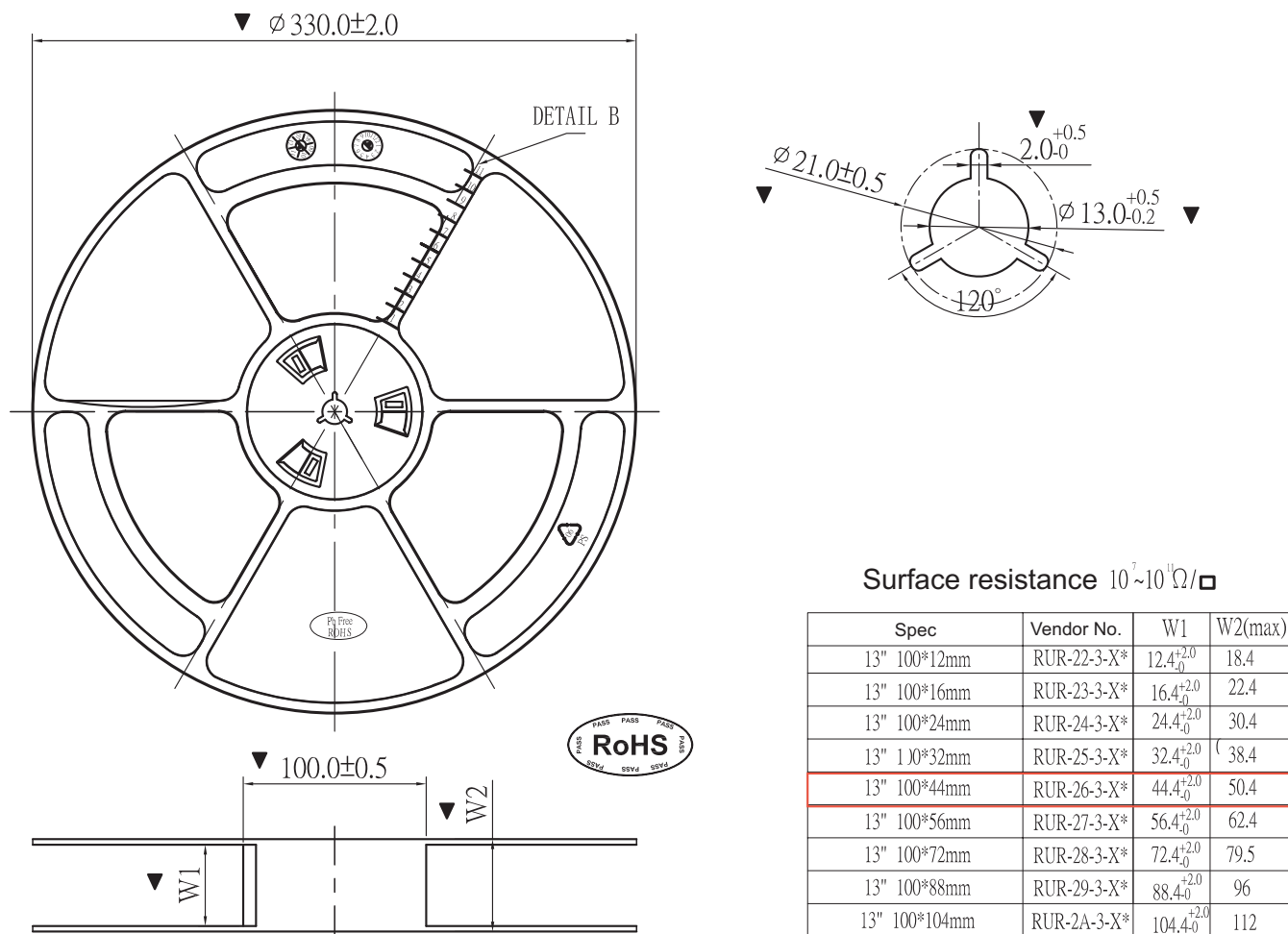
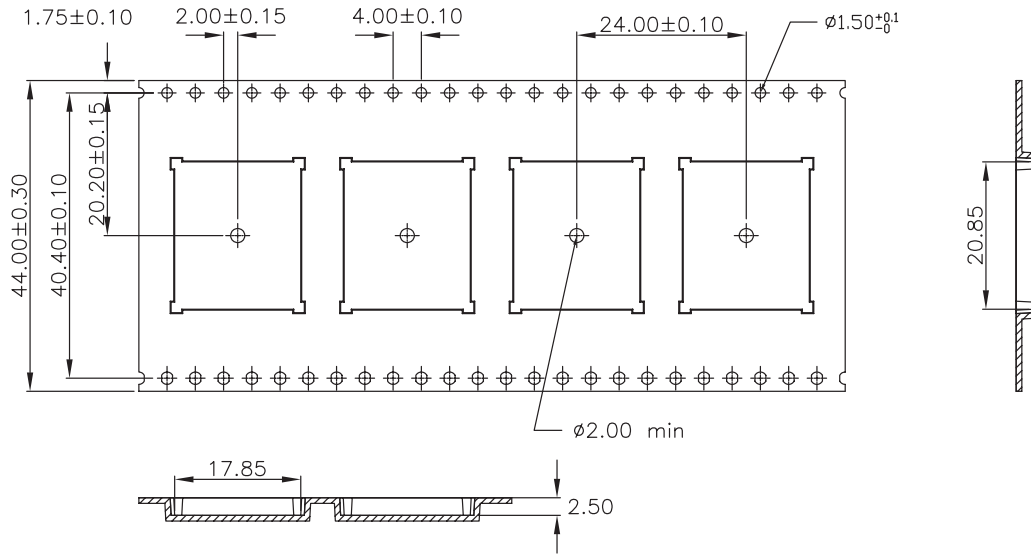

Figure 10-1. Tape Specification



W	44.00±0.30
A0	17.85±0.10
B0	20.85±0.10
K0	2.50±0.10

1. 10 sprocket hole pitch cumulative tolerance ±0.20.
2. Carrier camber is within 1 mm in 250 mm.
3. Material : Black Conductive Polystyrene Alloy.
4. All dimensions meet EIA-481-C requirements.
5. Thickness : 0.40±0.05mm.
6. Packing length per 13" reel : 25 Meters.
7. Component load per 7" reel : 1000 pcs

Figure 10-2. Reel Specification

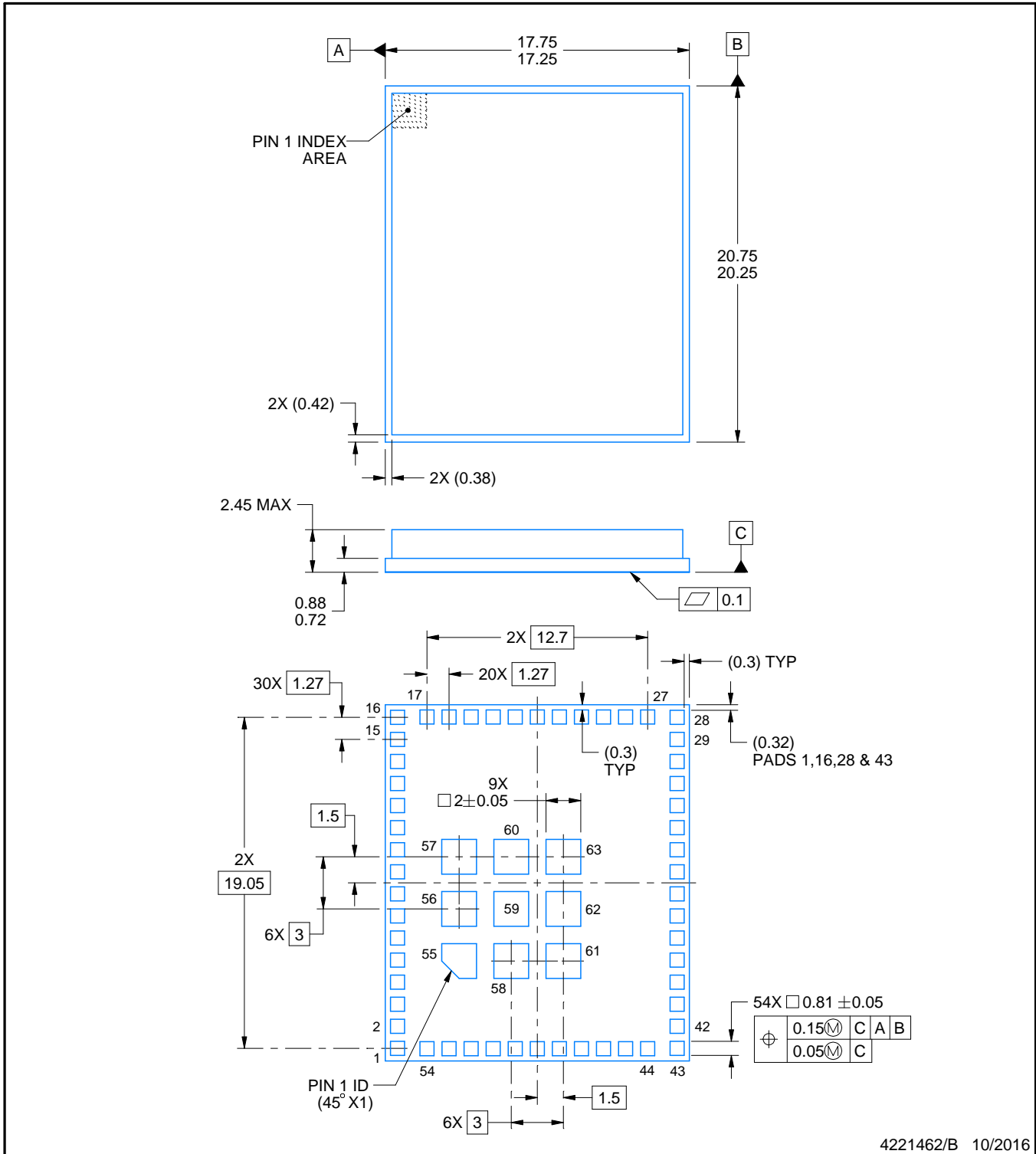
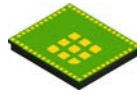

4221462/B 10/2016

NOTES:

1. All linear dimensions are in millimeters. Any dimensions in parenthesis are for reference only. Dimensioning and tolerancing per ASME Y14.5M.
2. This drawing is subject to change without notice.

EXAMPLE BOARD LAYOUT

MOB0063A

QFM - 2.45 mm max height

QUAD FLAT MODULE

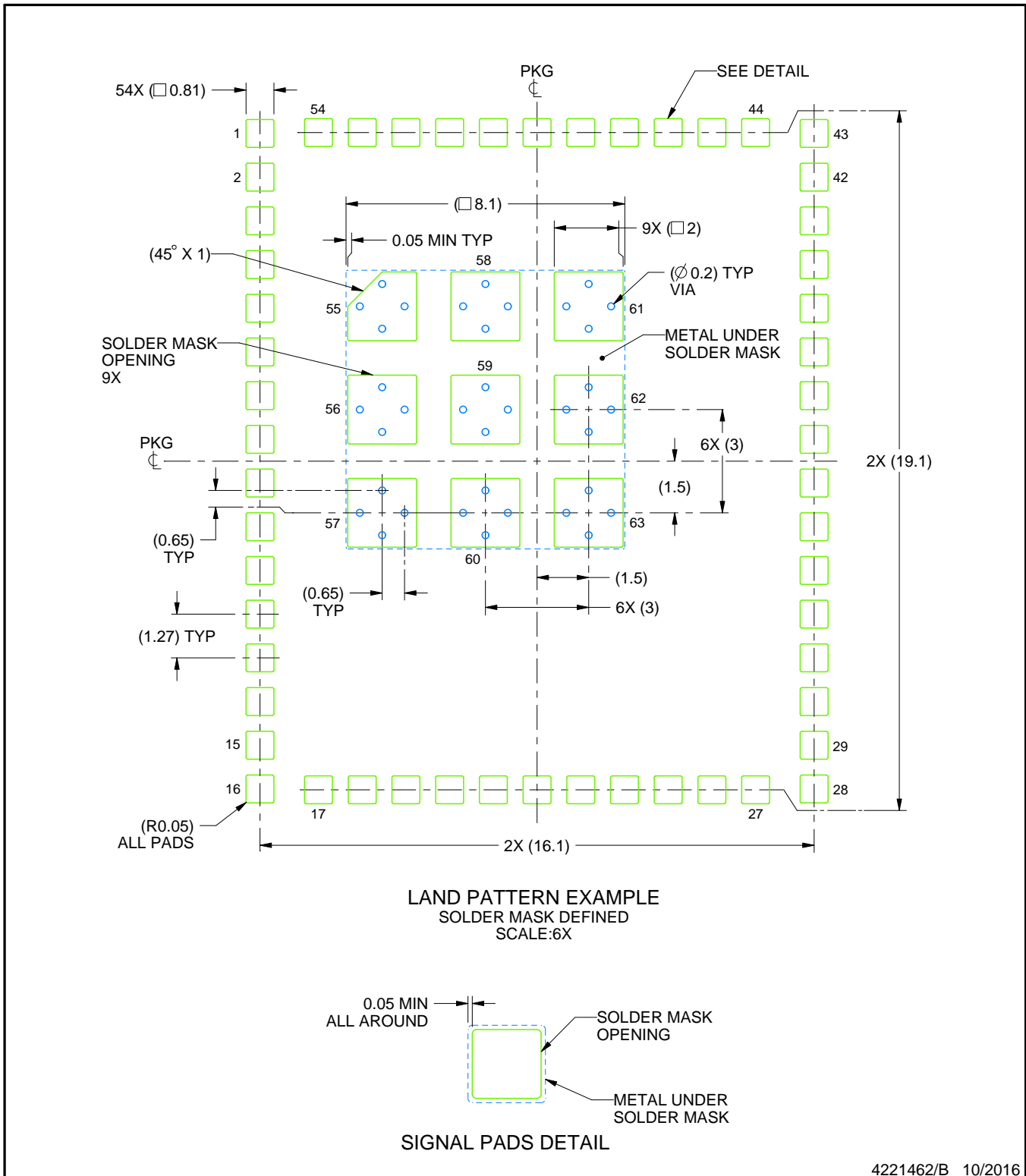

4221462/B 10/2016

NOTES: (continued)

3. This package is designed to be soldered to a thermal pad on the board. For more information, see Texas Instruments literature number SLUA271 (www.ti.com/lit/slua271).

EXAMPLE STENCIL DESIGN

MOB0063A

QFM - 2.45 mm max height

QUAD FLAT MODULE

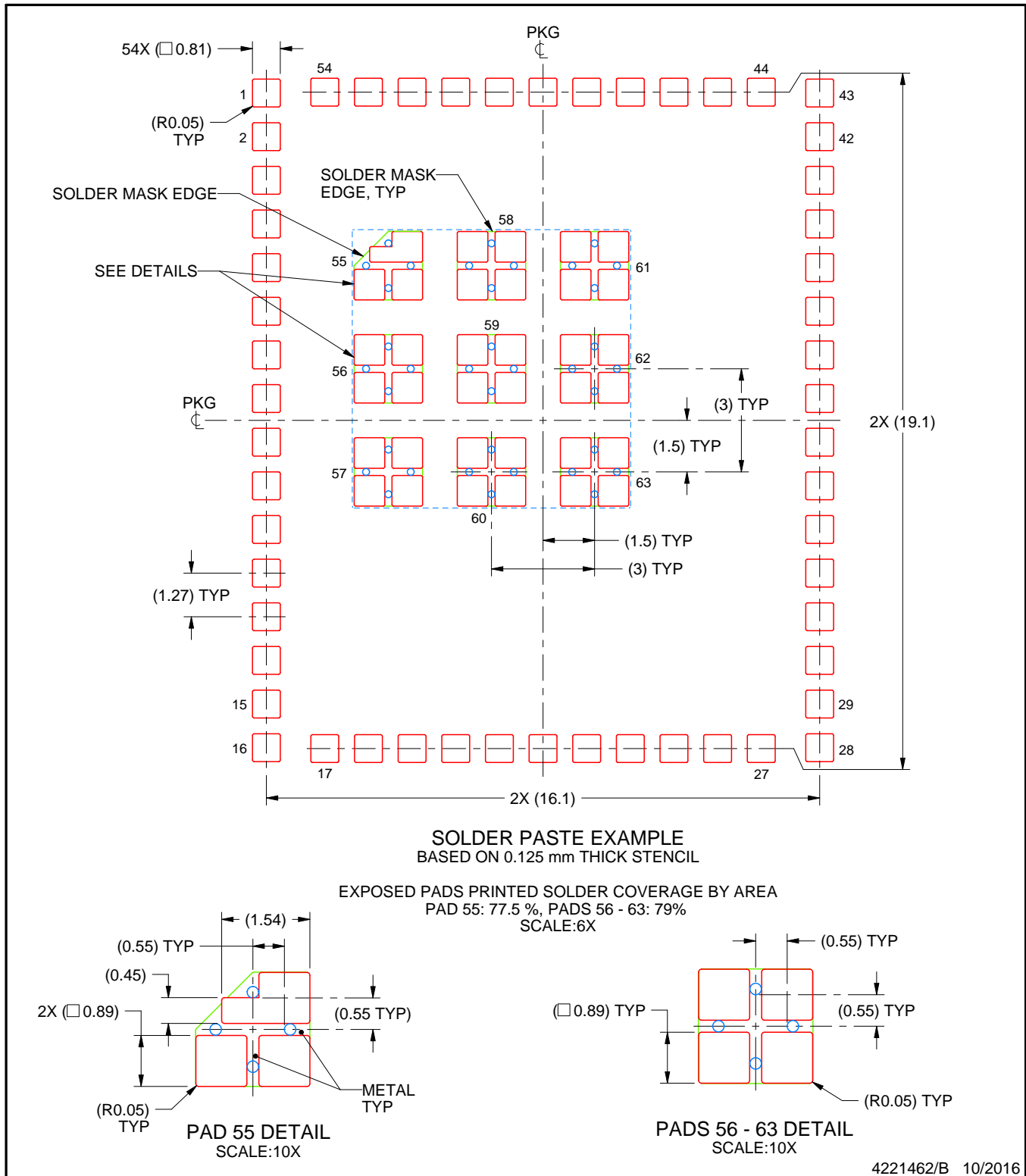

NOTES: (continued)

4. Laser cutting apertures with trapezoidal walls and rounded corners may offer better paste release. IPC-7525 may have alternate design recommendations.

IMPORTANT NOTICE

Texas Instruments Incorporated (TI) reserves the right to make corrections, enhancements, improvements and other changes to its semiconductor products and services per JESD46, latest issue, and to discontinue any product or service per JESD48, latest issue. Buyers should obtain the latest relevant information before placing orders and should verify that such information is current and complete.

TI's published terms of sale for semiconductor products (<http://www.ti.com/sc/docs/stdterms.htm>) apply to the sale of packaged integrated circuit products that TI has qualified and released to market. Additional terms may apply to the use or sale of other types of TI products and services.

Reproduction of significant portions of TI information in TI data sheets is permissible only if reproduction is without alteration and is accompanied by all associated warranties, conditions, limitations, and notices. TI is not responsible or liable for such reproduced documentation. Information of third parties may be subject to additional restrictions. Resale of TI products or services with statements different from or beyond the parameters stated by TI for that product or service voids all express and any implied warranties for the associated TI product or service and is an unfair and deceptive business practice. TI is not responsible or liable for any such statements.

Buyers and others who are developing systems that incorporate TI products (collectively, "Designers") understand and agree that Designers remain responsible for using their independent analysis, evaluation and judgment in designing their applications and that Designers have full and exclusive responsibility to assure the safety of Designers' applications and compliance of their applications (and of all TI products used in or for Designers' applications) with all applicable regulations, laws and other applicable requirements. Designer represents that, with respect to their applications, Designer has all the necessary expertise to create and implement safeguards that (1) anticipate dangerous consequences of failures, (2) monitor failures and their consequences, and (3) lessen the likelihood of failures that might cause harm and take appropriate actions. Designer agrees that prior to using or distributing any applications that include TI products, Designer will thoroughly test such applications and the functionality of such TI products as used in such applications.

TI's provision of technical, application or other design advice, quality characterization, reliability data or other services or information, including, but not limited to, reference designs and materials relating to evaluation modules, (collectively, "TI Resources") are intended to assist designers who are developing applications that incorporate TI products; by downloading, accessing or using TI Resources in any way, Designer (individually or, if Designer is acting on behalf of a company, Designer's company) agrees to use any particular TI Resource solely for this purpose and subject to the terms of this Notice.

TI's provision of TI Resources does not expand or otherwise alter TI's applicable published warranties or warranty disclaimers for TI products, and no additional obligations or liabilities arise from TI providing such TI Resources. TI reserves the right to make corrections, enhancements, improvements and other changes to its TI Resources. TI has not conducted any testing other than that specifically described in the published documentation for a particular TI Resource.

Designer is authorized to use, copy and modify any individual TI Resource only in connection with the development of applications that include the TI product(s) identified in such TI Resource. NO OTHER LICENSE, EXPRESS OR IMPLIED, BY ESTOPPEL OR OTHERWISE TO ANY OTHER TI INTELLECTUAL PROPERTY RIGHT, AND NO LICENSE TO ANY TECHNOLOGY OR INTELLECTUAL PROPERTY RIGHT OF TI OR ANY THIRD PARTY IS GRANTED HEREIN, including but not limited to any patent right, copyright, mask work right, or other intellectual property right relating to any combination, machine, or process in which TI products or services are used. Information regarding or referencing third-party products or services does not constitute a license to use such products or services, or a warranty or endorsement thereof. Use of TI Resources may require a license from a third party under the patents or other intellectual property of the third party, or a license from TI under the patents or other intellectual property of TI.

TI RESOURCES ARE PROVIDED "AS IS" AND WITH ALL FAULTS. TI DISCLAIMS ALL OTHER WARRANTIES OR REPRESENTATIONS, EXPRESS OR IMPLIED, REGARDING RESOURCES OR USE THEREOF, INCLUDING BUT NOT LIMITED TO ACCURACY OR COMPLETENESS, TITLE, ANY EPIDEMIC FAILURE WARRANTY AND ANY IMPLIED WARRANTIES OF MERCHANTABILITY, FITNESS FOR A PARTICULAR PURPOSE, AND NON-INFRINGEMENT OF ANY THIRD PARTY INTELLECTUAL PROPERTY RIGHTS. TI SHALL NOT BE LIABLE FOR AND SHALL NOT DEFEND OR INDEMNIFY DESIGNER AGAINST ANY CLAIM, INCLUDING BUT NOT LIMITED TO ANY INFRINGEMENT CLAIM THAT RELATES TO OR IS BASED ON ANY COMBINATION OF PRODUCTS EVEN IF DESCRIBED IN TI RESOURCES OR OTHERWISE. IN NO EVENT SHALL TI BE LIABLE FOR ANY ACTUAL, DIRECT, SPECIAL, COLLATERAL, INDIRECT, PUNITIVE, INCIDENTAL, CONSEQUENTIAL OR EXEMPLARY DAMAGES IN CONNECTION WITH OR ARISING OUT OF TI RESOURCES OR USE THEREOF, AND REGARDLESS OF WHETHER TI HAS BEEN ADVISED OF THE POSSIBILITY OF SUCH DAMAGES.

Unless TI has explicitly designated an individual product as meeting the requirements of a particular industry standard (e.g., ISO/TS 16949 and ISO 26262), TI is not responsible for any failure to meet such industry standard requirements.

Where TI specifically promotes products as facilitating functional safety or as compliant with industry functional safety standards, such products are intended to help enable customers to design and create their own applications that meet applicable functional safety standards and requirements. Using products in an application does not by itself establish any safety features in the application. Designers must ensure compliance with safety-related requirements and standards applicable to their applications. Designer may not use any TI products in life-critical medical equipment unless authorized officers of the parties have executed a special contract specifically governing such use. Life-critical medical equipment is medical equipment where failure of such equipment would cause serious bodily injury or death (e.g., life support, pacemakers, defibrillators, heart pumps, neurostimulators, and implantables). Such equipment includes, without limitation, all medical devices identified by the U.S. Food and Drug Administration as Class III devices and equivalent classifications outside the U.S.

TI may expressly designate certain products as completing a particular qualification (e.g., Q100, Military Grade, or Enhanced Product). Designers agree that it has the necessary expertise to select the product with the appropriate qualification designation for their applications and that proper product selection is at Designers' own risk. Designers are solely responsible for compliance with all legal and regulatory requirements in connection with such selection.

Designer will fully indemnify TI and its representatives against any damages, costs, losses, and/or liabilities arising out of Designer's non-compliance with the terms and provisions of this Notice.