

DASH NO.	M CODE	MADE FROM
----------	--------	-----------

GSD

1209-1-15 MA9

REVISIONS

ISSUE	CHANGES
2	CN 38588 E REDRAWN TML 06/12/02

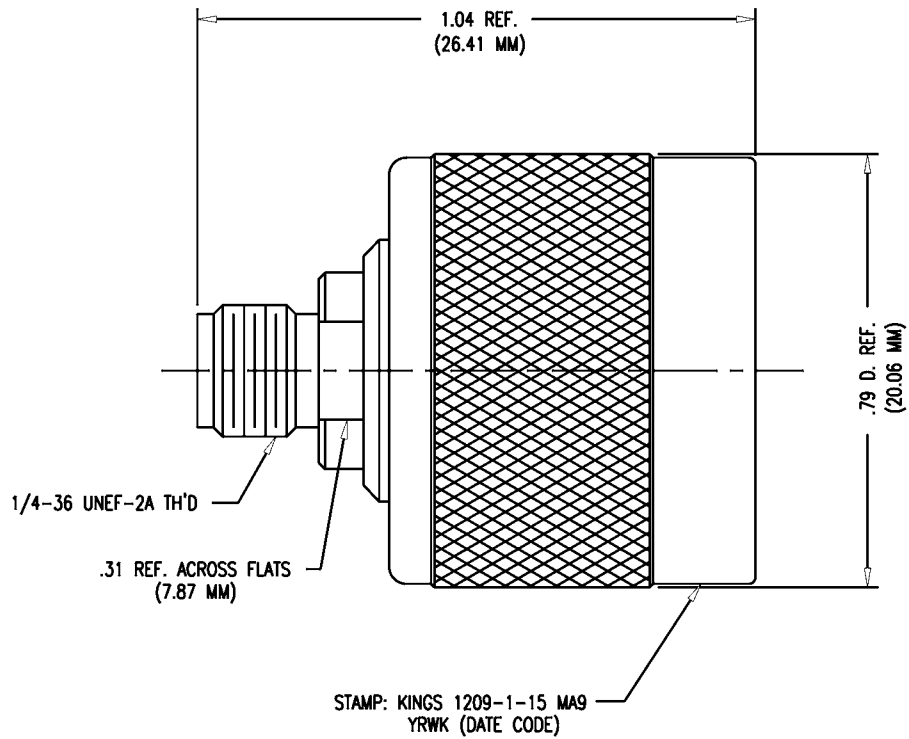

NOTES:

- INTERFACES PER MIL-STD-348, FIG. 304-1 & FIG. 310-2.
- MATERIALS:
INSULATOR: TEFLON, ASTM-D-1457
GASKET: SILICONE RUBBER, ZZ-R-765
CENTER CONTACT: BER. COP., ASTM-B-196
ALL OTHER METAL PARTS-BRASS, ASTM-B16
- FINISHES:
ALL METAL PARTS: GOLD PLATE PER MIL-G-45204
- ELECTRICAL CHARACTERISTICS:
NOMINAL IMPEDANCE: 50 OHMS
FREQUENCY RANGE: DC TO 11 GHZ
WORKING VOLTAGE: 500 VRMS

SCALE 4:1

APPROX SURFACE AREA

USED ON

REF:

ADAPTER, M-F,
N-SMA

DRAWN CT DATE 02/14/84

DESIGN MJB DATE 02/25/84

APPR. DATE

KINGS
ELECTRONICS CO., INC.
ROCK HILL, SOUTH CAROLINA 29730

1209-1-15 MA9

GSD