

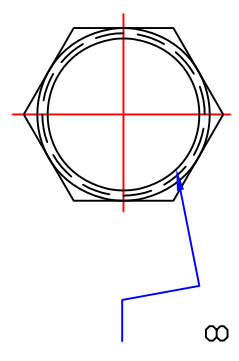

Product NO.		DOSIN-801-0043		
REV	DESCRIPTION	DWN	DATE	APPROVEN
A	First Issue	Mr. Wang	2010/08/19	John Kine

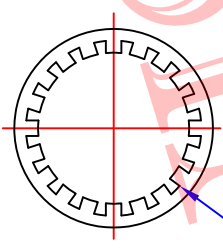
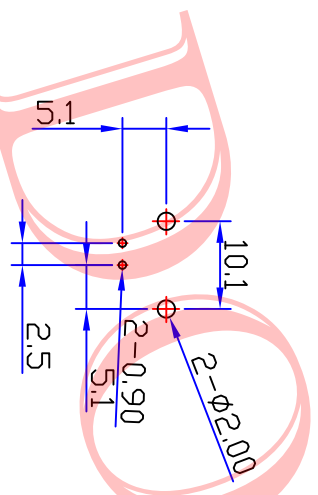
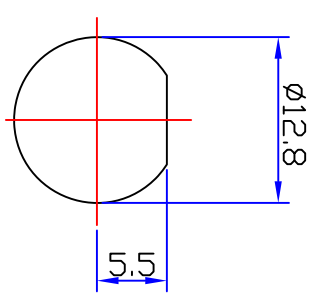
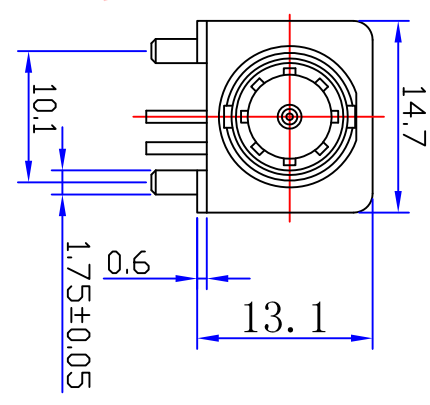
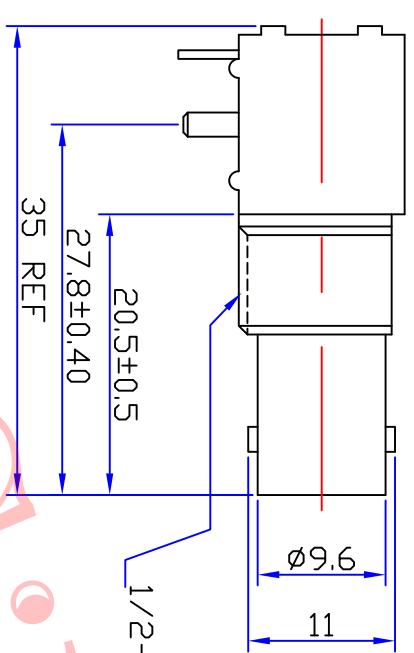
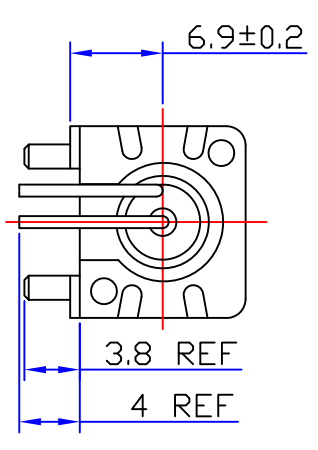

LOCK WASHER

1/2-28UNEF-2B  
CLAMP NUT

**Specification:**  
 Impedance: 75 Ohms  
 VSWR: 1.3MAX  
 Frequency range: DC~4G  
 Working Voltage: 500V rms @ sea level  
 Insulation resistance: 5000 Ohms min  
 Temperature range: -55°C T0 +155°C  
 Relative temperature: ≤95% (40°C ±2°C)  
 Drawings products are in line with ROHS standards.

RECOMMENDED MOUNTING HOLE  
 MAXIMUM PANEL THICKNESS: 5.5MM  
 RECOMMENDED MOUNTING TORQUE:  
 12 INCH-POUNDS MAX

1	Body	Zinc	NI: 80-120u"
2	Center contact	Brass	AU: 1u"
3	Lead	Iron	AU: 1u"
4	Fixed footrest	Iron	NI: 80-120u"
5	Insulator	POM	White
6	Fixed mount	PBT	White
7	Washer	IRON	NI: 80-120u"
8	Hex nut	Brass	NI: 80-120u"

NO	Component Number	Material	Finish
1			

NOTE:	
Tolerance	X, X.X, X.XX, Angular ±5°
View	MM

SCALE	1:1
APPROVALS	
CHECKED	Zelin Zhang
DRAWN	

**DOSIN** COMMUNICATION  
**Dosin Industrial(H.K)Co.,Ltd**  
 东莞市德索五金电子有限公司  
**Dosin Hardware Electronics Co., Ltd**  
 E-mail: dosin2005@163.com  
 dosin2005@dosin-china.com  
 Web: http://www.chin-guan.com  
 TEL: (0086) 769-81153906  
 FAX: (0086) 769-81875836

Name: BNC Jack 90° PCB Mount

SIZE: A  
 Product NO. DOSIN-801-0043

Date/Time	2012/04/13	CAD FILE	D/company drawings/BD	SHEET: 1 OF 1
-----------	------------	----------	-----------------------	---------------