

D-7TC
 CONTACTOR-SPDT
 50AMP 28VDC

REVISIONS

REV.	ECO	DESCRIPTION	DATE	APPROVED
F	20775	ITEM-16 PART NUMBER WAS 41194-001	31MAY1990	JD

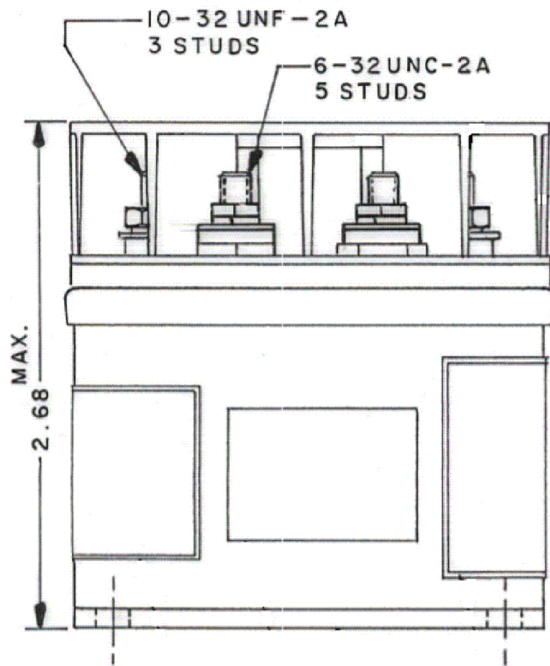
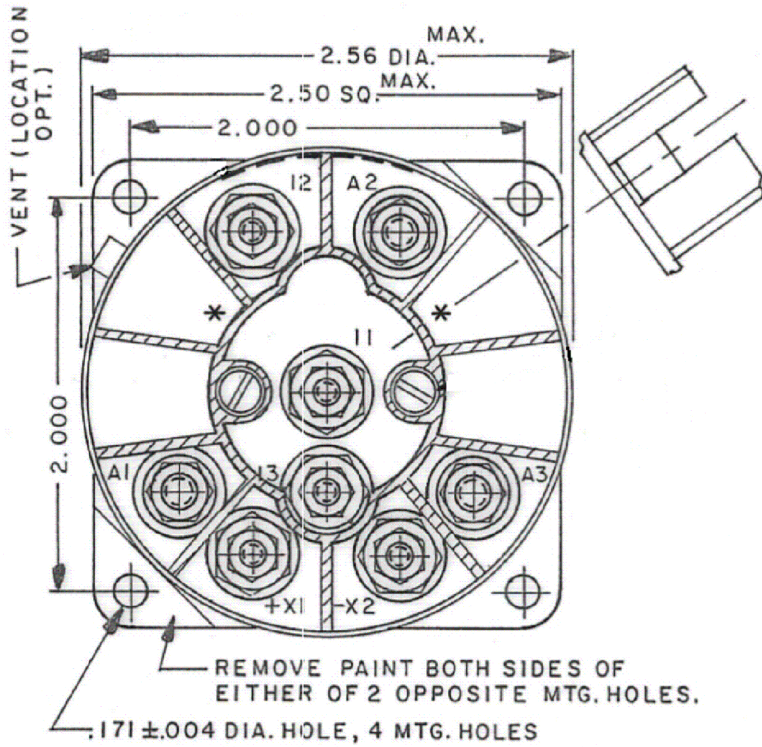

ALL DIMENSIONS ARE IN INCHES



TE CONNECTIVITY
 175 N. DIAMOND STREET MANSFIELD,
 OHIO 44902

TITLE

CONTACTOR-SPDT
 50AMP 28VDC

TE P.N.

1-1616933-7

DWG NO.

D-7TC

DS

DATA SHEET

CAGE CODE
 74063

SCALE
 NONE

SHEET
 1 OF 2

REV
 F

GENERAL SPECIFICATION

FAA/PMA

CONSTRUCTION	GASKET SEALED & VENTED
NOMINAL VOLTAGE	28 VDC
CONTACT ARRANGEMENT	
MAIN	SPDT DOUBLE BREAK
AUX	SPDT SINGLE BREAK
CONTACT RATING	50 AMP , 28 VDC
	500 AMP MAX INTERRUPTING CAPABILITY
II, 12, 13	5 AMP , 28 VDC OR 115 VAC 400 HZ
COIL RATING	28 VDC
PICKUP	18 VOLTS MAX HOT
DROPOUT	1.5 -7 VOLTS MAX HOT
RATED DUTY	CONTINUOUS
TEMP RATING	-55°C TO +71°C
MAX WEIGHT	13 OZ
COIL RESISTANCE	126 OHM

NOTES

1. COIL TRANSIENT VOLTAGE LIMITED TO
± 42. VOLT REFERENCED TO ZERO VOLTS.
2. * TERMINAL SHIELD NOTCHED TWO
PLACES FOR TERMINAL LEADS NO. 11 & 13

SCHEMATIC

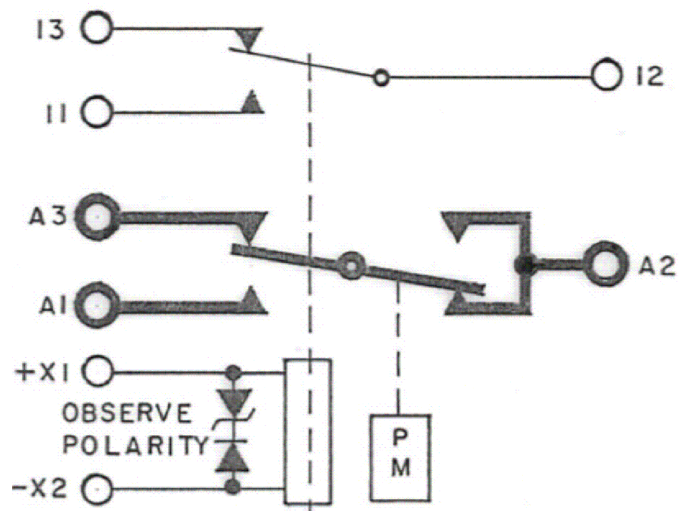

TE CONNECTIVITY
175 N. DIAMOND STREET MANSFIELD,
OHIO 44902

TITLE

CONTACTOR-SPDT
50AMP 28VDC

TE P.N.

1-1616933-7

DWG NO.

D-7TC

DS

DATA SHEET

CAGE CODE
74063

SCALE
NONE

SHEET
2 OF 2

REV
F