

THIS DOCUMENT IS THE PROPERTY OF
KEYSTONE ELECTRONICS CORP. AND
SHALL NOT BE REPRODUCED, DISTRIBUTED
OR USED AS A BASIS FOR MANUFACTURE
WITHOUT PRIOR WRITTEN PERMISSION
FROM KEYSTONE ELECTRONICS CORP.

ACTUAL SIZE

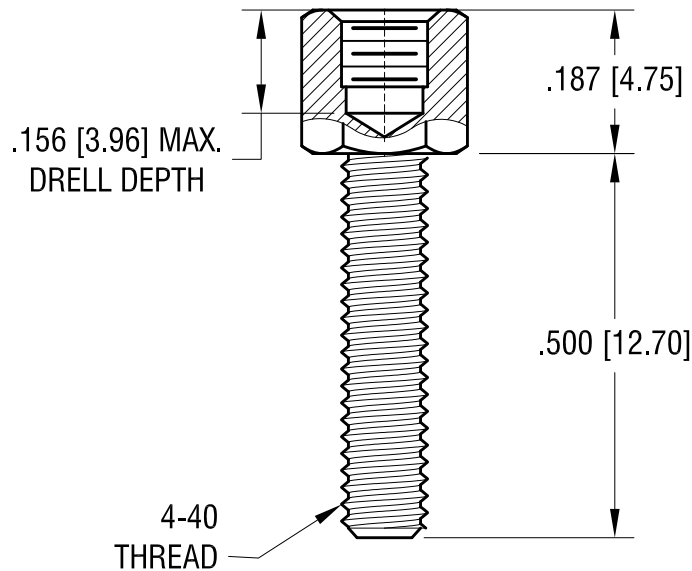
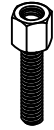
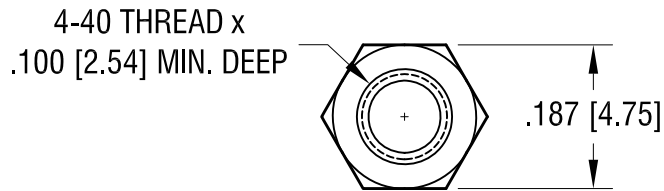

KEYSTONE ELECTRONICS CORP.

www.keyelco.com • NEW HYDE PARK NY 11040 • Tel (516)328-7500

PART NAME

JACK SCREW

MATERIAL

STEEL

FINISH ZINC PLATE
CLEAR CHROMATE

DRN BY BOONE

DATE 2.01.06

APP'D RH

SCALE 4X

TOLERANCES INCH [MM]
DECIMAL ± .005 [± 0.13]
ANGULAR ± 1°
UNLESS OTHERWISE SPECIFIED

CODE

DWG NO.

C

7243-5

12.13.23 SPLIT C/M DRAWING TO 'C' &'M
CHANGE AS PER ECN 23-307

A

REV.

DATE

DESCRIPTION