

För icke direkt toleranssatta mått gäller toleransklass
General tolerances if not otherwise stated

NOM DIM MM		TOL CLASS		
From	To	A	B	C
(1)	6	±0.05	±0.1	±0.2
(6)	30	±0.1	±0.2	±0.5
(30)	100	±0.15	±0.3	±0.8
(100)	300	±0.2	±0.5	±1.2
(300)	1000	±0.3	±0.8	±2

Hål / Holes H13

Skarpa kanter brutna där ej annat anges.
No sharp edges unless otherwise specified.

Övriga generella toleranser enligt ritning 4100-4644.
Additional general tolerances in accordance with drawing 4100-4644.

LASERMÄRKT ENLIGT RITNING : 4101-0261 F
LASERMARKED ACCORDING TO DRAWING : 4101-0261 F

Rev	Change order	Change: A = Added W = Was D = Deleted	Date	Sign
3	1014994000	4101-0272 ÄNDRAD/CHANGED	021017	SE
4	1016252000	4101-0261F ÄNDRAD/CHANGED	030508	SE

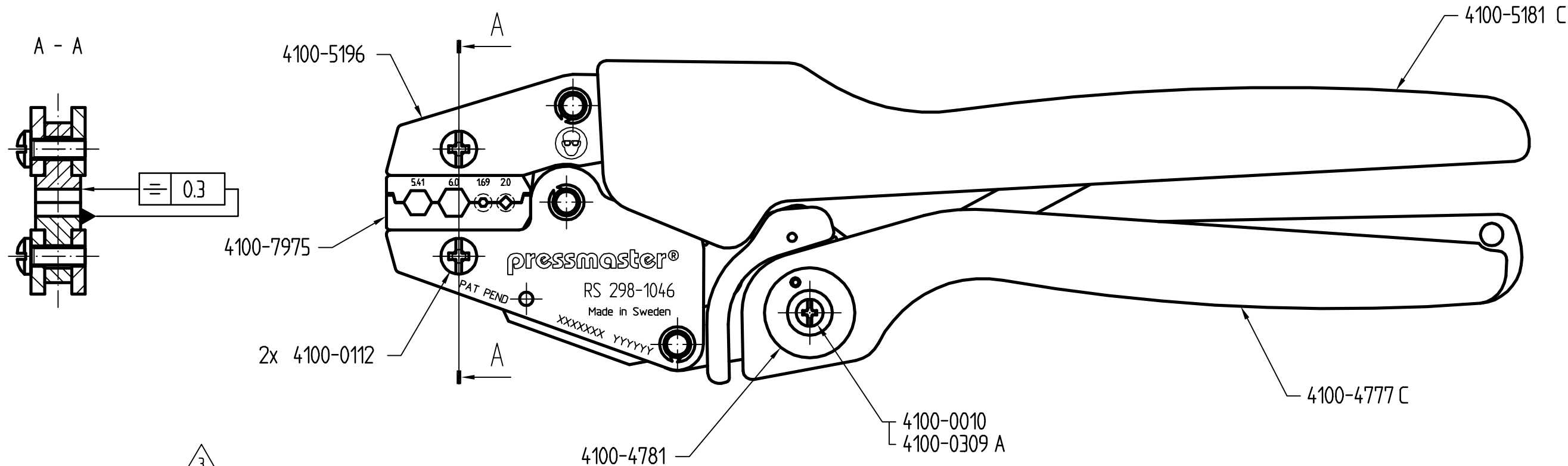
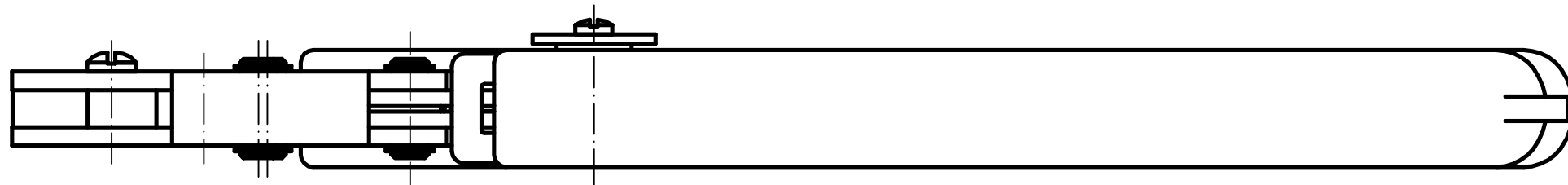

FÖRSPÄNNING / PRELOAD: 190 ± 40 N

Tolkmått / Gauge dimensions (mm)		
URTAG NEST	Gåttolk GO	Stopptolk NO GO
5.41	Ø5.36	Ø5.46
6.0	Ø5.95	Ø6.05
1.69	Ø1.66	Ø1.72
2.0	Ø1.97	Ø2.03

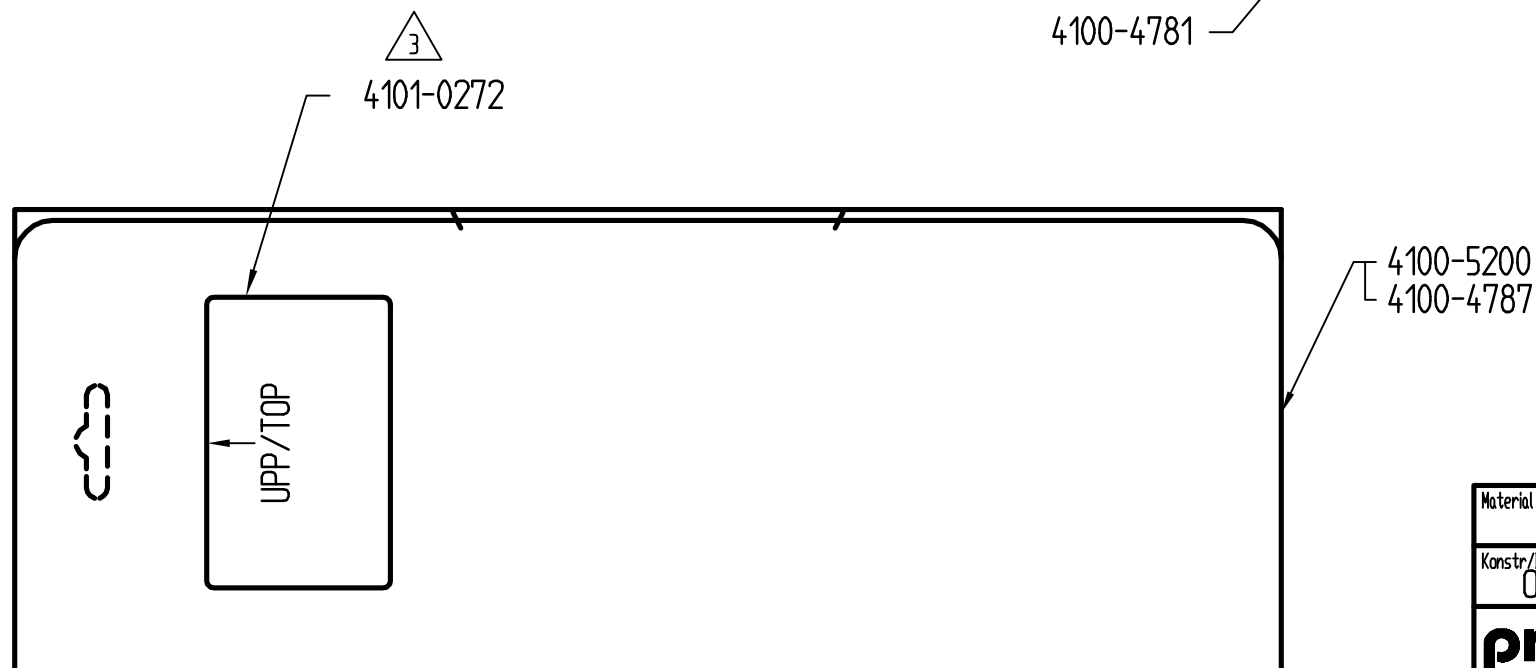

Denna ritning är Pressmaster AB:s egendom. Skyddad av gällande lag.
This drawing is the property of Pressmaster AB. Protected in accordance with prevailing law.

Material		Behandling/Treatment			Status Prel.utc.	
Konstr./Design OS	Ritad/Drawn LJ	Datum/Date 980420	Skala/Scale 1:1	Kontr./Checked	Godk./Approved	Ämne/Blank
pressmaster®				Benämning/Denomination KRIMPTÅNG 298-1046		Vikt/Weight, gram Art grp 012
ISO 9001 REG NR FM13687				CRIMPING TOOL		Ritn nr/Drawing no 43002436 REV 004