

# AVERY DENNISON MARKETING SPECIFICATION

THE SUBJECT MATTER DISCLOSED HEREIN EMBODIES PROPRIETARY INFORMATION WHICH IS THE CONFIDENTIAL PROPERTY OF THE AVERY DENNISON CO. NONE OF WHICH SHALL BE COPIED, REPRODUCED, DISCLOSED TO OTHERS, PUBLISHED OR USED IN WHOLE OR IN PART, FOR ANY PURPOSE OTHER THAN THAT FOR WHICH IT IS BEING MADE AVAILABLE WITHOUT THE EXPRESS ADVANCE WRITTEN PERMISSION OF A DULY AUTHORIZED AGENT OF THE COMPANY. THIS DOCUMENT IS THE PROPERTY OF THE AVERY DENNISON CO. AND IS TO BE RETURNED TO THE COMPANY ON DEMAND.

HISTORY		
REV.	DATE	DESCRIPTION
A	2/17/15	RELEASE

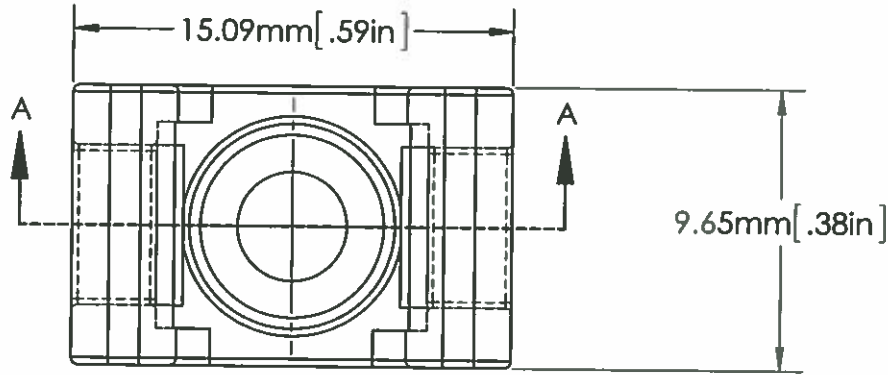

SCALE 4 : 1

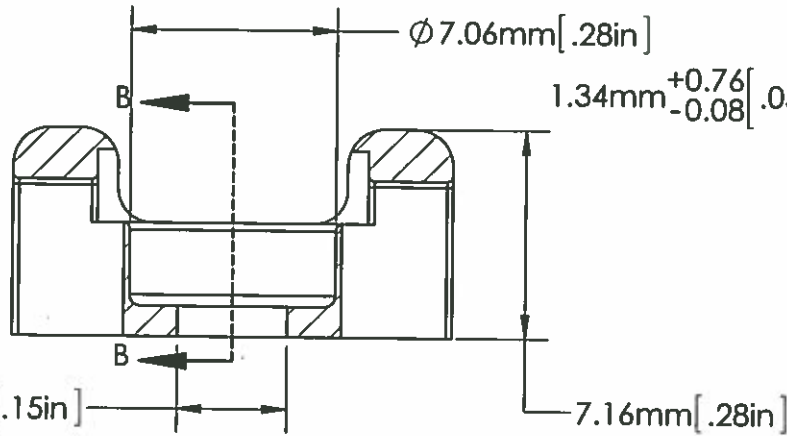

SECTION A-A  
SCALE 4 : 1

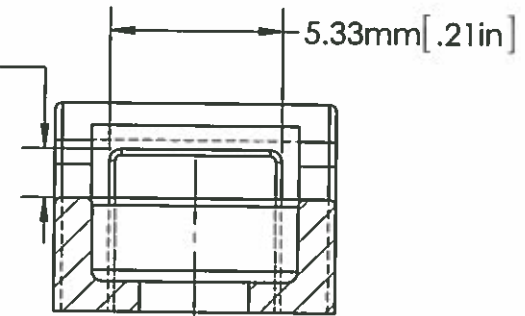

SECTION B-B  
SCALE 4 : 1



APPROVALS:	ENG. APPR. <i>[Signature]</i> 2-17-15	<b>AVERY DENNISON</b> <small>FASTENER DIVISION                  FITCHBURG, MA 01420 U.S.A.                  TEL: 1-800-225-5913                  FAX: 978-353-8157</small>
	Q.A. APPR. <i>[Signature]</i> 2-23-15	
SPECIFIED TOLERANCES ARE:		DESCRIPTION
.XX ± .03 INCHES .XX ± .25 MM		<b>CRADLE MOUNT, SMALL</b>
ANGULAR: ± 2°		STOCK NO. <b>10044-2</b>
MATERIAL <b>NYLON 6/6</b>		REV. <b>A</b>
COLOR <b>NATURAL</b>		

WEIGHT:	.012 oz. / 0.34 grams
MOUNTING:	# 6 (FLATHEAD SCREW)
PACKAGING:	100/BAG, 5000/CASE

5

4

3

2

1

# Mouser Electronics

Authorized Distributor

Click to View Pricing, Inventory, Delivery & Lifecycle Information:

[Avery Dennison:](#)

[10044](#) [10044-0](#)