

規格承認書

PECIFICATION FOR APPROVAL

客戶

CUSTOMER : 立創

項目

ITEM : 铁壳内磁喇叭

型號

TYPE : GSPK5010TN-8R2W 内磁

描述

DESCRIPTION : ϕ 50*H8mm 8R 2W S.P.L: 96dB \pm 3dB

客戶料號

CUSTOMER NO.:

規格書號

SPECIFICATION NO.:

版本

EDITION NO. : V1.0

日期

DATE : 2021-9-17

客戶承認

CUSTOMER CONFIRM AND SIGN

檢查 TESTED BY	審核 CHECKED BY	承認 APPROVED BY

東莞市贏海電子有限公司

DONGUAN INGHAI ELECTRONICS CO.,LTD

製作 ISSUED BY	審查 CHECKED BY	確認 APPROVED BY
周明	刘承成	

地址：广东省东莞市长安镇上沙管理区新春 1 路新春科技园

電話 / TEL: 0769-83060958 傳真 / FAX: 0769-81608993

網址: HTTP://WWW.INGHAI.COM

A. SCOPE 範疇

This specification applies speaker, GSPK5010TN-8R2W 內磁
此規格書適用於喇叭, GSPK5010TN-8R2W 內磁

1. 測試條件 TEST CONDITION

Unless otherwise specified, the standard range of atmospheric conditions for making measurements and tests are as follows (無特定要求時如下述測試條件): 15°C~35°C, 25%~85%RH, 860mbar~mbar.

If there is no doubt about the results, measurement shall be made with in the following limits (當判定有疑義的場合如下述測試條件): 20°C±3°C, 60%~70%RH, 860mbar~1060mbar.

2. 一般規範 GENERAL SPECIFICATIONS

NO.	ITEM	SPECIFICATIONS
1.	類型 Type	FULL RANGE
2.	口徑 Dimensions	2" inch
3.	重量 Weight	14.8g±2g/PC

3. 電氣特性 ELECTRICAL AND SPECIFICATION

型号	Φ 50×8 8 欧 2W				
阻抗	8±20% at 1 kHz				
灵敏度	96±2dB				
频率响应 (F0)	550Hz-650Hz				
测试设备	JH6160(R)				
电压输入	1.5V				
工作温度	-20°C O +50°C				
工作湿度	30%~75%RH (NO dew condensation)				
保存环境温度	-20°C O +50°C				
保存环境湿度	20%~80% (Water vapor pressure 6643pa Max)				
保存期	1 year				
上机不良品	10ppm Max				

材料名称	物料编号	材料成分	材料含量(%)	供应商	备注
外壳	JY000002	壳体	55	川洋	
夹板	JY000003	薄板	15	樊氏电子配件厂	
磁钢	JY000005	磁铁	25	鑫林磁钢	
线路板	JY000006	镀银	5	维嘉微电子	

检查项目	重要等级	抽样标准	检查方法	检查标准	
外观	焊锡	A	G-II, AQL=0.25	用目视观察	无发黄, 斑点。
	外壳	B	G-II, AQL=0.25	用目视观察	无严重色差, 无明显划痕。
	产品标识	B	G-II, AQL=0.01	用目视观察	产品标识要求字迹清楚, 字样与合同评审相符

4. 揚聲器模式測量示意圖 SPEAKER MODE MEASUREMENT DIAGRAM

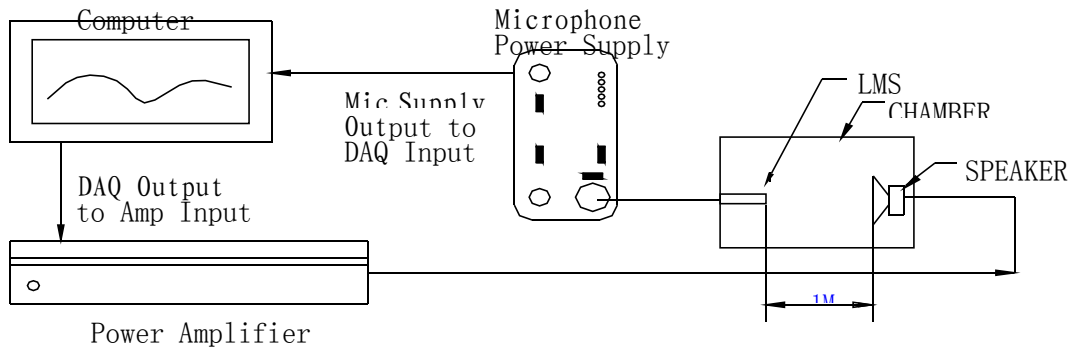

5. 環境試驗特性 ENVIRONMENTAL CHARACTERISTICS

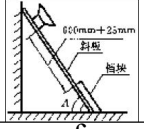
NO.	ITEM	CONDITIONS
1.	工作溫度 Operating temperature range	-20°C ~ +50°C
2.	貯存溫度 Storage temperature range	-25°C ~ +65°C
3.	外觀檢測 Appearance	Should not exist any obstacle to be harmful to normal operation : damages \ cracks \ rusts and distortions etc.
4.	試驗後檢測 Results of after test	Sensitivity difference shall be within (3dB) and should satisfy the test described under item 3.7 after each following test.
5.	拉力試驗 Terminal strength	Capable of withstanding (2N) load for (10 sec.) without resulting in any damage or rejection .
6.	高溫試驗 High temperature durability	After having been in a test chamber for 16 hours at the condition of +55°C ±2°C and then let 6 hours in a room .
7.	低溫試驗 Low temperature durability	After having been in a test chamber for 16 hours at the condition of -20°C ±3°C and then let 6 hours in a room .
8.	濕度試驗 Humidity durability	After having been in a test chamber for 48 hours at the condition of +40°C ±2°C 90%~95% RH and then let 6 hours in a room .
9.	溫度循環試驗 Temperature cycle durability	Low temperature -10 °C ±2°C (1 hour) / high temperature +55 ± 2 °C (1 hour) : 1 cycle , total 5 cycles and then let 6 hours in a room .
10.	振動試驗 (捆包狀態) Vibration durability (PACK)	Frequency Range: 10Hz ~ 55Hz~10Hz Amplitude : 0.35mm Duration : 2h per axis=10 cycles ; 3 axis
11.	跌落沖擊試驗 Drop impact test	Speaker magnetic circuit part of the fall line a distance of 600mm ± 25mm. Angle A is 60° ± 5° . 
12.	絕緣抵抗 Insulation resistance	Voice coil and magnetic circuit terminal and cone frame between the metal parts of the insulation resistance of not less than 1 MΩ 音圈引出端與盆架和磁路的金屬部分之間的絕緣電阻不小 1MΩ
13.	連續負荷 Load test	Rated Power, Pink Noise at 460HZ-9KHz applied for 96 Hours. After Test, Meet Item 3.7

6. 頻率響應曲線 FREQUENCY RESPONSE CURVE

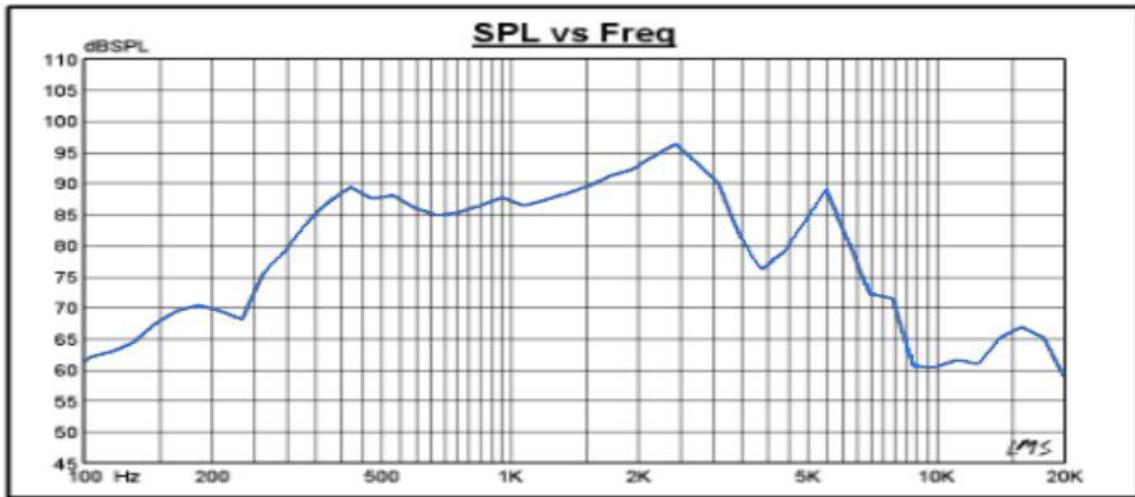

7. 阻抗曲線& T/S 參數曲線 IMPEDANCE CURVE & T/S PARAMETER CURVE

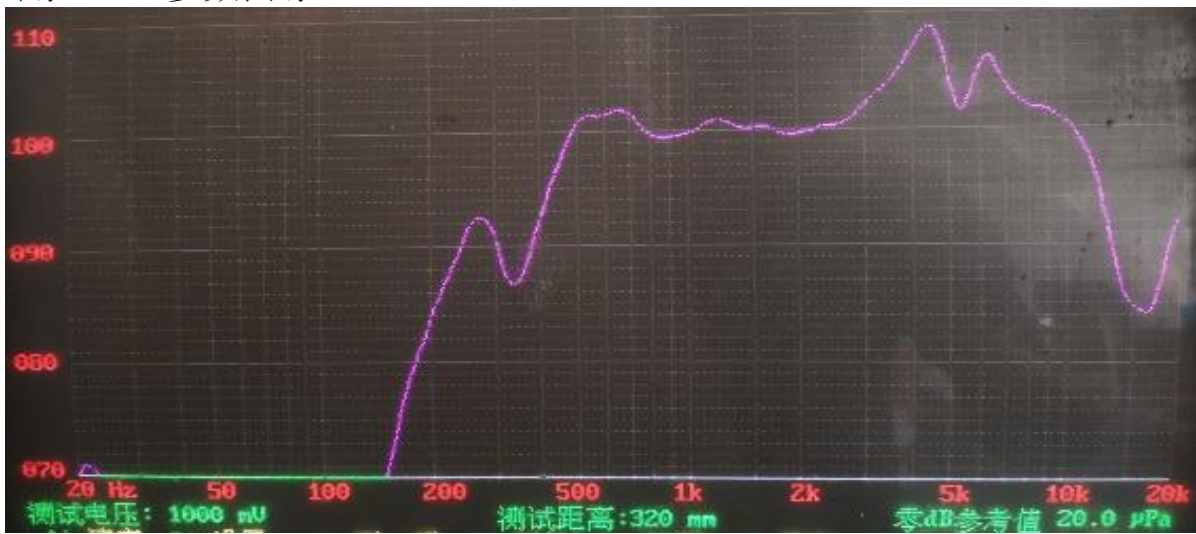

D. APPEARANCE DRAWING 外觀尺寸圖



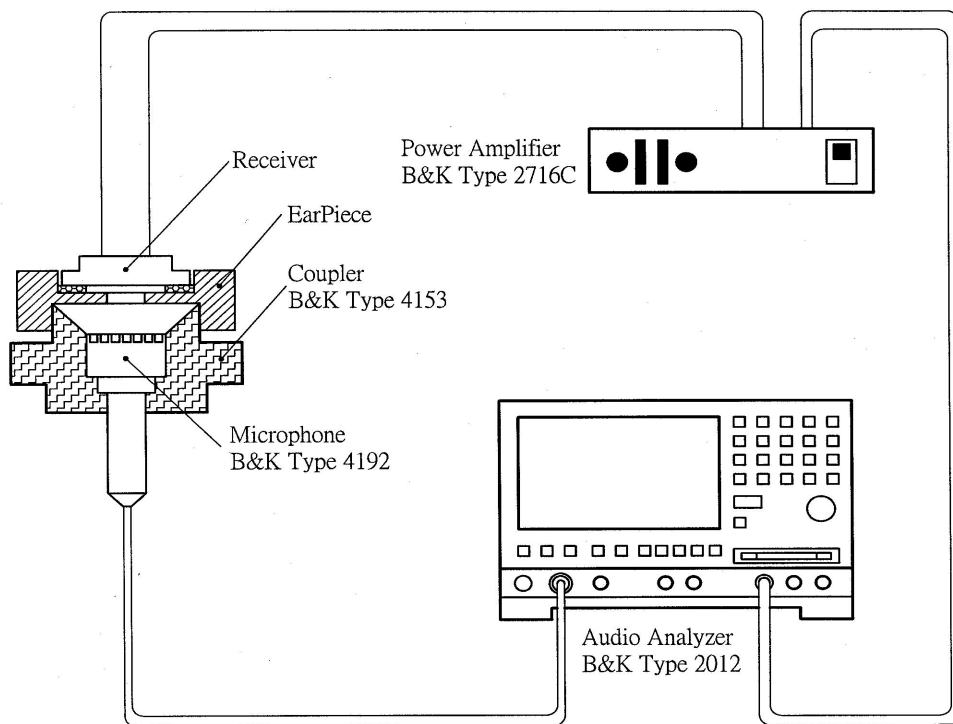
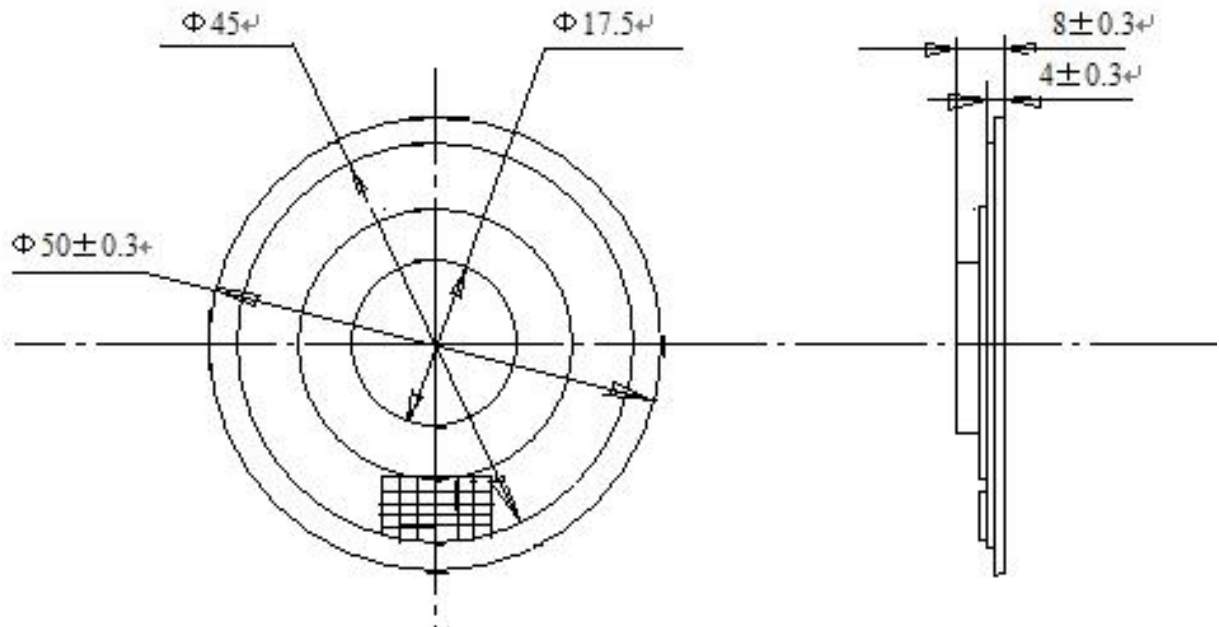

F. MECHANICAL CHARACTERISTICS 機械特性

No.	Item	Test conditions	Evaluation standard
1	PCB Wire Pull Strength PCB 線材拉力	The pull force shall be applied to double lead wire : Horizontal 3.0N(0.306kg) for 30 seconds. 雙線材水平方向施以 3.0N(0.306kg)的力量,30 秒.	No damage and cutting off. 不鬆動,不脫落.

2	Vibration test 振動測試	Receiver shall be measured after being applied vibration of amplitude of 1.5mm with 10 to 55hz band of vibration frequency to each of 3 per-pendicular directions for 2 hours. 振動週波數 10~55HZ、全振幅 1.5mm 於 X.Y.Z 3 個方向,各 2 小時.	No obstacle to be harmful to normal operation; damages, cracks, rusts and distortions. Should not be audible at 890mV sine wave between 50Hz ~ 20KHz
3	Drop test 落下測試	Drop the receiver contained in normal box onto the board 40mm thick 10 times from the height of 75cm 將受話器置於盒中, 自 75 公分高度落在 40mm 木板上共 10 次.	測試後無任何障礙防礙正常操作.且在輸入 890mV 正弦波從 50Hz 到 20KHz 之間無異常音.

G. ENVIRONMENTAL TEST 環境試驗

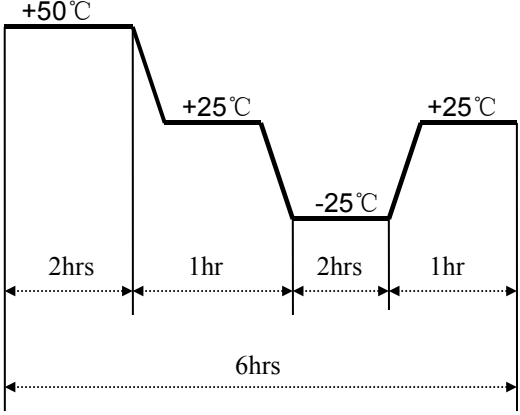
No.	Item	Test conditions	Evaluation standard
1	High temp. Test 高溫測試	After being placed in a chamber at +50°C for 796hours 置於+50°C 環境 96 小時	Being placed for 6 hours at +25°C, receiver shall be measured. No obstacle to be harmful to normal operation; damages, cracks, rusts, etc. Should not be audible at 890mV, sine wave between 50Hz ~20KHz. S.P.L. deviation of unit should be within ±3dB 經測試後, 靜置於+25°C (室溫) 環境中 6 小時後, 測試後無任何障礙防礙正常操作. 且在輸入 890mV 正弦波從 50Hz 到 20KHz 之間無異常音. 輸出音壓變化量在±3dB 內.
2	Low temp. Test 低溫測試	After being placed in a chamber at -25°C for 96 hours. 置於-25°C 環境中 96 小時	
3	Humidity test 相對濕度測試	After being placed in a chamber at +40 °C and 95±5%RH relative humidity for 96 hours. 置於+40°C, 相對濕度 95±5%環境中 96 小時.	
4	Thermal cycle test 溫度循環測試	The part shall be subjected to 6 cycles. One cycle shall be consist of : 單體承受溫度循環測 6 次,其循環內容如圖示: 	

H. Recommended Temperature Profile For Hand Soldering 建議手焊溫度

Hand Soldering
320 ± 10°C / 3 ± 1 Sec

I. RELIABILITY TEST 信賴性試驗

No.	Item	Test conditions	Evaluation standard
1	Load test 連續負荷	565mV white noise is applied for 24 hours, at room temp. 在室溫下,輸入功率 565mV, 白雜音連續操作 24 小時.	Being placed for 1 hours at +25°C, receiver shall be measured. No obstacle to be harmful to normal operation; damages, cracks, rusts, etc. Should not be audible at 890mV sine wave between 50Hz ~20KHz. S.P.L. deviation of unit should be within ±3dB 經測試後, 靜置於+25°C (室溫)環境中 1 小時後,測試後無任何障礙防礙正常操作. 且在輸入 890mV 正弦波從 50 到 20KHz 之間無異常音.輸出音壓變化量在±3dB 內.

TEST CONDITION.

Standard Test Condition :	a) Temperature : +5 ~ +35°C	b) Humidity : 45-85%	c) Pressure : 860-1060mbar
一般測試條件 :	a) 溫度 : +5 ~ +35°C	b) 濕度 : 45-85%	c) 氣壓 : 860-1060mbar
Judgment Test Condition	a) Temperature : +25 ± 2°C	b) Humidity : 60-70%	c) Pressure : 860-1060mbar
爭議時測試條件:	a) 溫度 : +25 ± 2°C	b) 濕度 : 60-70%	c) 氣壓 : 860-1060mbar

手工焊接溫度 300±5°C, 焊接時間 2±0, 5S。 $\Delta f/f < 10\text{ppm}$, $\Delta RS < 10\%$

标准包装	SHIPPING MARK		标签
外包装	纸箱		
内包装	泡沫盒		

- 1, 泡沫包装盒数量: 200PCS
- 2, 外箱数量: 1400PCS
- 3, 净重: 19KG 毛重: 20KG