



SPC
TECHNOLOGY

ALL RIGHTS RESERVED. NO PORTION OF THIS PUBLICATION, WHETHER IN WHOLE OR IN PART CAN BE REPRODUCED WITHOUT THE EXPRESS WRITTEN CONSENT OF SPC TECHNOLOGY.

SPC-F005.DWG

REVISIONS

| DCP # | REV | DESCRIPTION | DRAWN | DATE | CHECKD | DATE | APPRVD | DATE |
|-------|-----|-------------|-------|----------|--------|----------|--------|----------|
| | | | AMU | 02-08-10 | MRE | 05-08-10 | XXX | 16-08-10 |

DOC. NO. SPC-F005 * Effective: 7/8/02 * DCP No: 1398

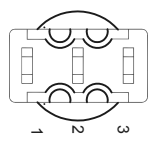
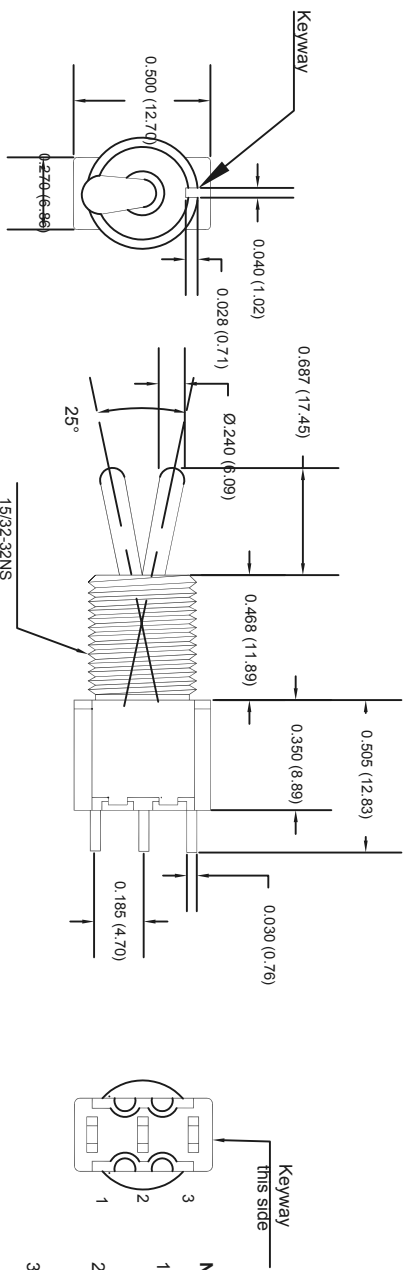

NOTES:

- Rating: 5 Amps with resistive load at 120 VAC or 28 VDC
- 2 Amps with resistive load at 250 VAC
- Contact Material: Contact Surface: Coin Silver
- Body: Coin Silver or silver plated brass
- Center Terminal: Contact Surface: Brass, silver plated
- Body: Brass, silver plated
- Electrical Life: 50,000 make-and-break cycles at full load
- Contact Resistance: 10 milliohm maximum
- Initial at 2 to 4 VDC 100 milliamp
- Operating Temperature: -30°C to 85°C
- Toggle Handle: Brass, chrome plated
- Bushing: Brass, nickel plated
- Housing: Stainless Steel
- U/L Listed
- Includes: Hex nut, lock washer and locking ring
- Insulation Resistance: 1000 Megohms minimum
- Dielectric Strength: 1000 V RMS at seal level

Part Number Table

| Description | Part Number |
|----------------------|-------------|
| Toggle Switch , Spot | SPC21274 |

Dimensions : Inches (mm)

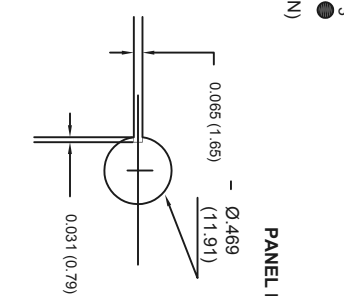
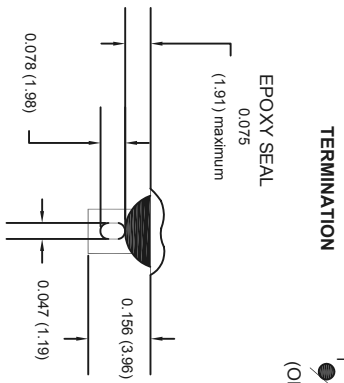

DISCLAIMER:
ALL STATEMENTS AND TECHNICAL INFORMATION CONTAINED HEREIN ARE BASED UPON INFORMATION AND/OR TESTS WE BELIEVE TO BE ACCURATE AND RELIABLE. SINCE CONDITIONS OF USE ARE BEYOND OUR CONTROL, THE USER SHALL DETERMINE THE SUITABILITY OF THE PRODUCT FOR THE INTENDED USE AND ASSUME ALL RISK AND LIABILITY WHATSOEVER IN CONNECTION THEREWITH.

TOLERANCES:
UNLESS OTHERWISE SPECIFIED, DIMENSIONS ARE FOR REFERENCE PURPOSES ONLY.

| | | | |
|--------------|-----|-------|----------|
| DRAWN BY: | AMU | DATE: | 02-08-10 |
| CHECKED BY: | MRE | DATE: | 05-08-10 |
| APPROVED BY: | XXX | DATE: | 16-08-10 |

| | | | |
|----------------|----------|-----------------------------|---------------|
| DRAWING TITLE: | | Toggle Switch , Spot | |
| SIZE | DWG. NO. | ELECTRONIC FILE | REV |
| XXX | XXX | 50N285 | A |
| SCALE: | NTS | U.O.M.: INCHES [mm] | SHEET: 1 OF 1 |