

# 40MHz to 500MHz Quadrature Demodulator with VGA

## FEATURES

- Wide Range 1.8V to 5.25V Supply
- Frequency Range: 40MHz to 500MHz
- -4dB to 59dB Variable Power Gain
- THD < 0.12% (-58dBc)  
at 800mV<sub>p-p</sub> Differential Output Level
- 8.8MHz I/Q Lowpass Output Noise Filters
- IF Overload Detector
- Baseband I/Q Amplitude Imbalance: 0.2dB
- Baseband I/Q Phase Imbalance: 0.6°
- 6.8dB Noise Figure at Max Gain
- Input IP3 at Low Gain: -0.5dBm
- Low Supply Current: 27mA
- Low Delay Shift Over Gain Control Range: 2ps/dB
- Outputs Biased Up While in Standby
- 16-Lead QFN 4mm x 4mm Package with Exposed Pad

## APPLICATIONS

- IEEE802.11
- High Speed Wireless LAN
- Wireless Local Loop

## DESCRIPTION

The LT<sup>®</sup>5506 is a 40MHz to 500MHz monolithic integrated quadrature demodulator with variable gain amplifier (VGA), designed for low voltage operation. It supports standards that use a linear modulation format. The chip consists of a VGA, quadrature down-converting mixers and lowpass noise filters. The LO port consists of a divide-by-two stage and LO buffers. The IC provides all building blocks for IF down-conversion to I and Q baseband signals with a single supply voltage of 1.8V to 5.25V. The VGA gain has a linear-in-dB relationship to the control input voltage. Hard-clipping amplifiers at the mixer outputs reduce the recovery time from a signal overload condition. The lowpass filters reduce the out-of-band noise and spurious frequency components. The cut-off frequency of the noise filters is approximately 8.8MHz. The external 2xLO frequency is required to be twice the IF input frequency for the mixers. The standby mode provides reduced supply current and fast transient response into the normal operating mode when the I/Q outputs are AC-coupled to a baseband chip.

LT, LTC and LT are registered trademarks of Linear Technology Corporation.

## TYPICAL APPLICATION

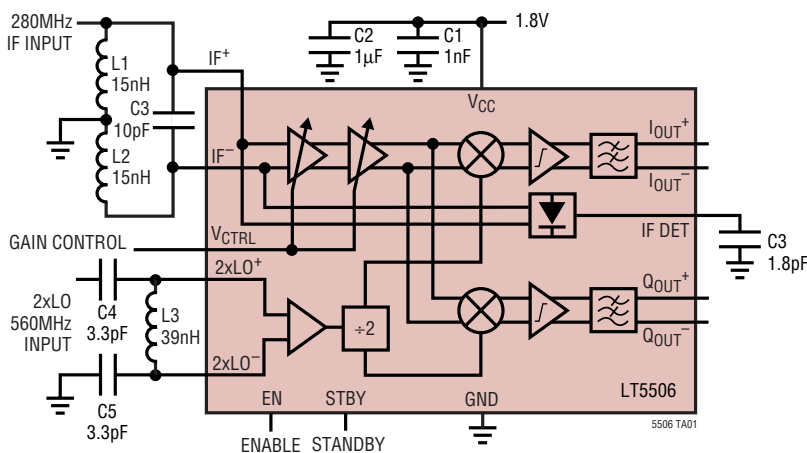

Total Harmonic Distortion vs  
IF Input Level at 1.8V Supply

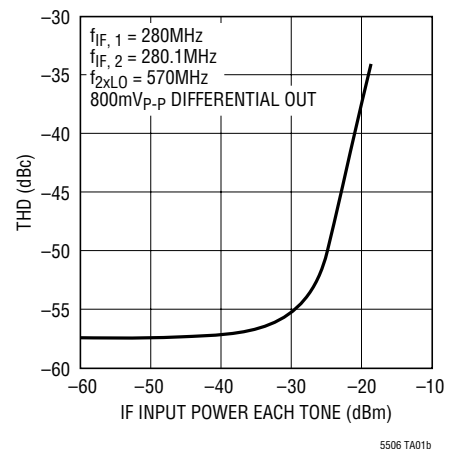

**ABSOLUTE MAXIMUM RATINGS**

(Note 1)

Supply Voltage .....	5.5V
Differential Voltage Between 2xLO <sup>+</sup> and 2xLO <sup>-</sup> .....	4V
IF <sup>+</sup> , IF <sup>-</sup> .....	-500mV to 500mV
I <sub>OUT</sub> <sup>+</sup> , I <sub>OUT</sub> <sup>-</sup> , Q <sub>OUT</sub> <sup>+</sup> , Q <sub>OUT</sub> <sup>-</sup> .....	V <sub>CC</sub> - 1.8V to V <sub>CC</sub>
Operating Ambient Temperature (Note 2) .....	-40°C to 85°C
Storage Temperature Range .....	-65°C to 125°C
Voltage on Any Pin Not to Exceed .....	-500mV to V <sub>CC</sub> + 500mV

**PACKAGE/ORDER INFORMATION**

<p>TOP VIEW</p> <p>UF PACKAGE 16-LEAD (4mm × 4mm) PLASTIC QFN</p> <p>T<sub>JMAX</sub> = 125°C, θ<sub>JA</sub> = 37°C/W EXPOSED PAD (PIN 17) IS GROUND MUST BE SOLDERED TO PCB</p>	<p>ORDER PART NUMBER</p> <p><b>LT5506EU</b></p>
---	---

Consult LTC Marketing for parts specified with wider operating temperature ranges.

**ELECTRICAL CHARACTERISTICS**

V<sub>CC</sub> = 3V, f<sub>2xLO</sub> = 570MHz, P<sub>2xLO</sub> = -5dBm (Note 5), f<sub>IF</sub> = 284MHz, P<sub>IF</sub> = -30dBm, I and Q outputs 800mV<sub>p-p</sub> into 4kΩ differential load, T<sub>A</sub> = 25°C, EN = V<sub>CC</sub>, STBY = V<sub>CC</sub>, unless otherwise noted. (Note 3)

SYMBOL	PARAMETER	CONDITIONS	MIN	TYP	MAX	UNITS
<b>IF Input</b>						
f <sub>IF</sub>	Frequency Range			40 to 500		MHz
	Nominal Input Level	R <sub>SOURCE</sub> = 200Ω Differential		-79 to -22		dBm
	Input Impedance	IF <sup>+</sup> , IF <sup>-</sup> to GND, EN = V <sub>CC</sub> IF <sup>+</sup> , IF <sup>-</sup> to GND, EN = GND		100Ω//1.2pF 1pF		
NF	Noise Figure at Max Gain	V <sub>CTRL</sub> = 1.7V		6.8		dB
G <sub>L</sub>	Min Gain (Note 4)	V <sub>CTRL</sub> = 0.2V		0.9	8	dB
G <sub>H</sub>	Max Gain (Note 4)	V <sub>CTRL</sub> = 1.7V	50	59		dB
IIP3	Input IP3, Min Gain	P <sub>IF</sub> = -22.5dBm (Note 7)		-0.5		dBm
	Input IP3, Max Gain	P <sub>IF</sub> = -75dBm (Note 7)		-49		dBm
IIP2	Input IP2, Max Gain	V <sub>CTRL</sub> = 1.7V		-8		dBm
<b>Demodulator I/Q Output</b>						
	Nominal Voltage Swing	(Note 6)		0.8		V <sub>p-p</sub>
	Clipping Level	(Note 6)		1.25		V <sub>p-p</sub>
	DC Common Mode Voltage			V <sub>CC</sub> - 1.19		V
	I/Q Amplitude Imbalance	(Note 8)		0.2	0.5	dB
	I/Q Phase Imbalance	(Note 8)		0.6	3	Deg
	DC Offset	(Notes 6, 8)		28		mV
	Output Driving Capability	Single Ended, C <sub>LOAD</sub> ≤ 10pF	2	1.5		kΩ
	STBY to Turn-On Delay			0.3		μs
	I/Q Output 1dB Compression			-11.5		dBm
	I/Q Output IM3	P <sub>IF, 1</sub> = -25.5dBm, 280MHz P <sub>IF, 2</sub> = -25.5dBm, 280.1MHz (Note 7)		-50		dBc

**ELECTRICAL CHARACTERISTICS**  $V_{CC} = 3V$ ,  $f_{2 \times LO} = 570MHz$ ,  $P_{2 \times LO} = -5dBm$  (Note 5),  $f_{IF} = 284MHz$ ,  $P_{IF} = -30dBm$ , I and Q outputs 800mV<sub>P-P</sub> into 4k $\Omega$  differential load,  $T_A = 25^\circ C$ ,  $EN = V_{CC}$ ,  $STBY = V_{CC}$ , unless otherwise noted. (Note 3)

SYMBOL	PARAMETER	CONDITIONS	MIN	TYP	MAX	UNITS
<b>Variable Gain Amplifier (VGA)</b>						
	Gain Slope Linearity Error	$V_{CTRL} = 0V$ to 1.4V		$\pm 0.5$		dB
	Temperature Gain Shift	$T = -40^\circ C$ to $85^\circ C$ , $V_{CTRL} = 0V$ to 1.4V		$\pm 0.3$		dB
	Gain Control Response Time	Settled within 10% of Final Value		100		ns
	Gain Control Voltage Range			0 to 1.7		V
	Gain Control Slope			43		dB/V
	Gain Control Input Impedance	To Internal 0.2V		25		k $\Omega$
	Delay Shift Over Gain Control	Measured Over 10dB Step		2		ps/dB
<b>Baseband Lowpass Filter</b>						
	-3dB Cutoff Frequency		7.2	8.8	10.4	MHz
	Group Delay Ripple			5		ns
<b>2xLO Input</b>						
$f_{2 \times LO}$	Frequency Range			80 to 1000		MHz
$P_{2 \times LO}$	Input Power	1:2 Transformer with 240 $\Omega$ Shunt Resistor (Note 5)	-20	-5		dBm
	Input Power	LC Balun (Note 5)		-10		dBm
	Input Impedance	Differential Between 2xLO <sup>+</sup> and 2xLO <sup>-</sup>		800 $\Omega$ /0.4pF		
	DC Common Mode Voltage			$V_{CC} - 0.4$		V
<b>IF Detector</b>						
	IF Detector Range	Referred to IF Input		-30 to 8		dBm
	Output Voltage Range	For $P_{IF} = -30dBm$ to 8dBm		0.3 to 1.2		V
	Detector Response Time	With External 1.8pF Load, Settling within 10% of Final Value		100		ns
<b>Power Supply</b>						
$V_{CC}$	Supply Voltage		1.8		5.25	V
$I_{CC}$	Supply Current	$EN = High$ , $STBY = Low$ or $High$		26.5	36	mA
$I_{OFF}$	Shutdown Current	$EN, STBY < 350mV$		0.2	30	$\mu A$
$I_{STBY}$	Standby Current	$EN = Low$ ; $STBY = High$		3.6	5.5	mA
<b>Mode</b>						
Enable	Enable Pin Voltage	$EN = High$	1			V
Disable	Enable Pin Voltage	$EN = Low$			0.5	V
Standby	Standby Pin Voltage	$STBY = High$	1			V
No Standby	Standby Pin Voltage	$STBY = Low$			0.5	V

**Note 1:** Absolute Maximum Ratings are those values beyond which the life of a device may be impaired.

**Note 2:** Specifications over the  $-40^\circ C$  to  $85^\circ C$  temperature range are assured by design, characterization and correlation with statistical process controls.

**Note 3:** Tests are performed as shown in the configuration of Figure 6. The IF input transformer loss is subtracted from the measured values.

**Note 4:** Power gain is defined here as the I (or Q) output power into a 4k $\Omega$  differential load, divided by the IF input power in dB. To calculate the voltage gain between the differential I output (or Q output) and the IF input, including ideal matching network,  $10 \cdot \log(4k\Omega/50) = 19dB$  has to be added to this power gain.

**Note 5:** If a narrow-band match is used in the 2xLO path instead of a 1:2 transformer with 240 $\Omega$  shunt resistor, 2xLO input power can be reduced to -10dBm, without degrading the phase imbalance. See Figure 11 and Figure 6.

**Note 6:** Differential between  $I_{OUT+}$  and  $I_{OUT-}$  (or differential between  $Q_{OUT+}$  and  $Q_{OUT-}$ ).

**Note 7:** The gain control voltage  $V_{CTRL}$  is set in such a way that the differential output voltage between  $I_{OUT+}$  and  $I_{OUT-}$  (or differential between  $Q_{OUT+}$  and  $Q_{OUT-}$ ) is 800mV<sub>P-P</sub>, with the given input power  $P_{IF}$ .

**Note 8:** The typical parameter is defined as the mean of the absolute values of the data distribution.

**TYPICAL PERFORMANCE CHARACTERISTICS**  $V_{CC} = 3V$ ,  $f_{2 \times LO} = 570MHz$ ,  $P_{2 \times LO} = -5dBm$   
 (Note 5),  $f_{IF} = 284MHz$ ,  $P_{IF} = -30dBm$ , I and Q outputs 800mV<sub>P-P</sub> into 4k $\Omega$  differential load,  $T_A = 25^\circ C$ ,  $EN = V_{CC}$ ,  $STBY = V_{CC}$ ,  
 unless otherwise noted. (Note 3)

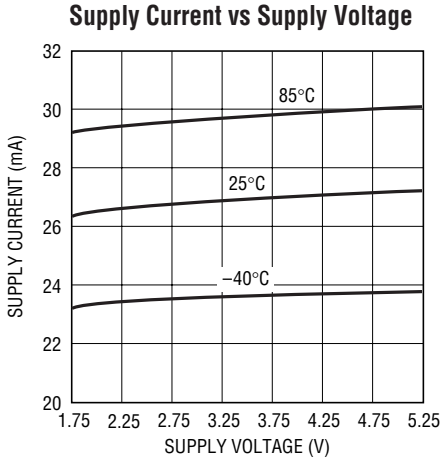

5506 G01

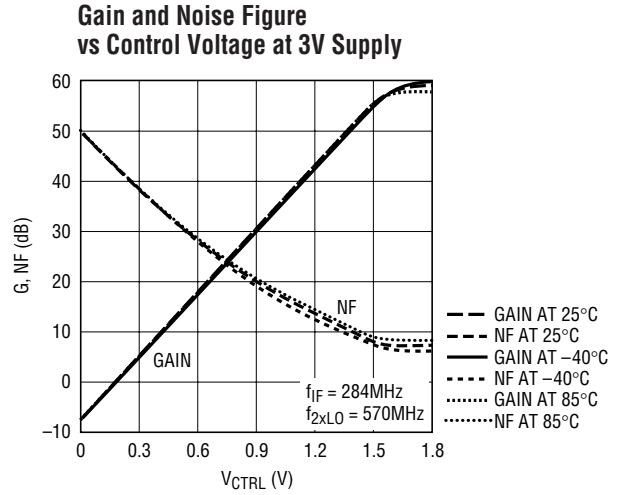

5506 G02

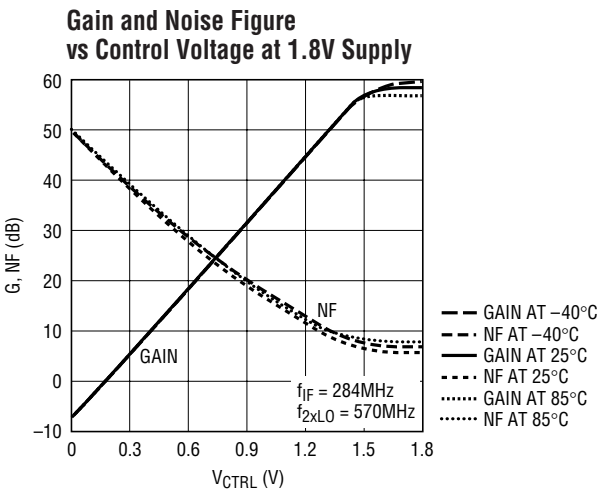

5506 G03

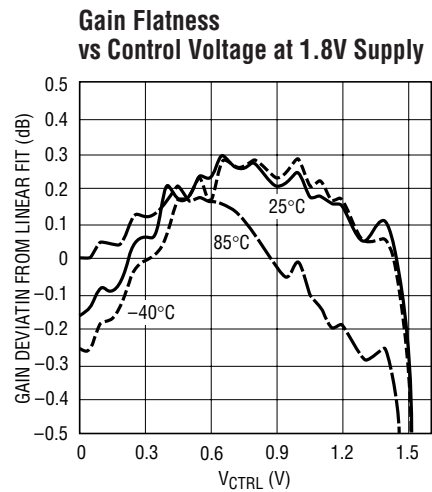

5506 G04

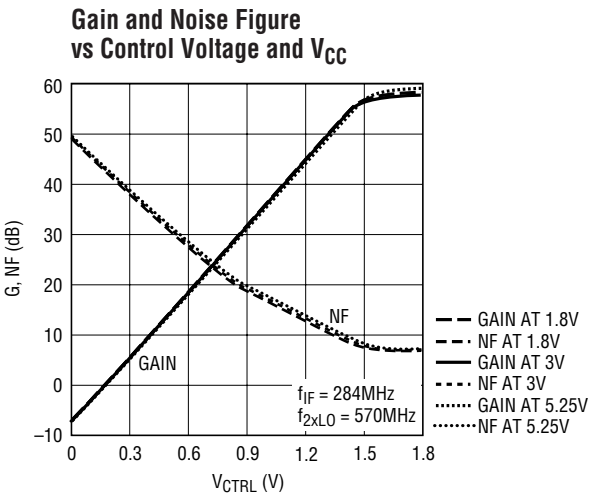

5506 G05

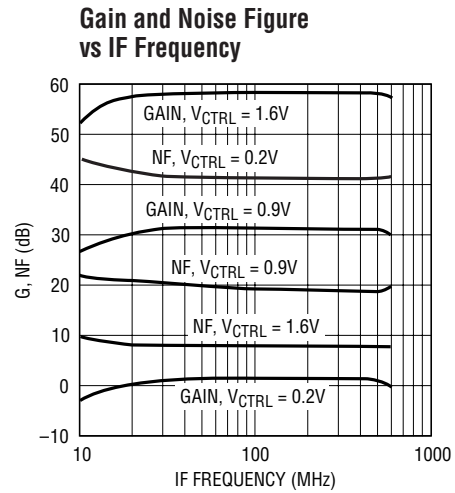

5506 G06

**TYPICAL PERFORMANCE CHARACTERISTICS**  $V_{CC} = 3V$ ,  $f_{2 \times LO} = 570MHz$ ,  $P_{2 \times LO} = -5dBm$   
 (Note 5),  $f_{IF} = 284MHz$ ,  $P_{IF} = -30dBm$ , I and Q outputs  $800mV_{p-p}$  into  $4k\Omega$  differential load,  $T_A = 25^\circ C$ ,  $EN = V_{CC}$ ,  $STBY = V_{CC}$ ,  
 unless otherwise noted. (Note 3)

**Total Harmonic Distortion vs IF Input Power at 3V Supply and 800mV<sub>p-p</sub> Differential Out**

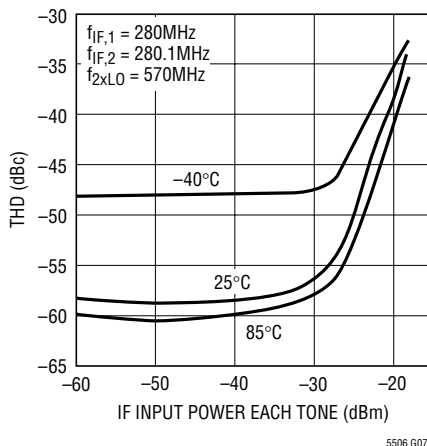

5506 G07

**Total Harmonic Distortion vs IF Input Power and IF Frequency**

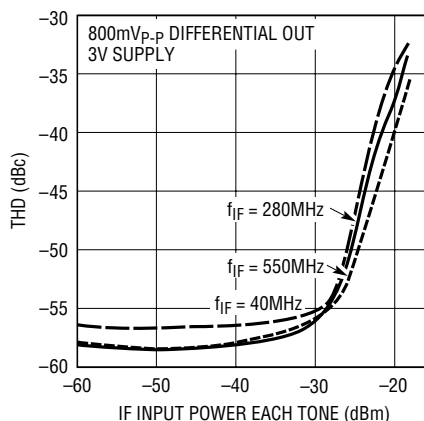

5506 G08

**Total Harmonic Distortion vs IF Input Power at 1.8V Supply and 800mV<sub>p-p</sub> Differential Out**

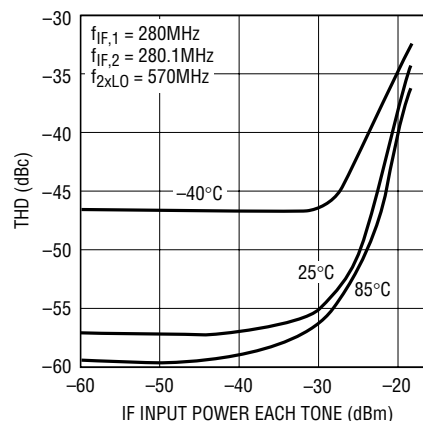

5506 G09

**Total Harmonic Distortion vs IF Input Power and Supply Voltage**

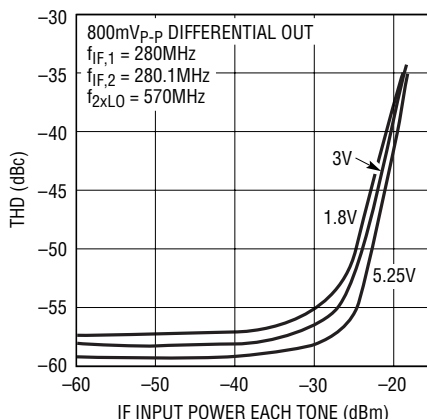

5506 G10

**Total Harmonic Distortion vs IF Input Power at 500mV<sub>p-p</sub> Differential Out**

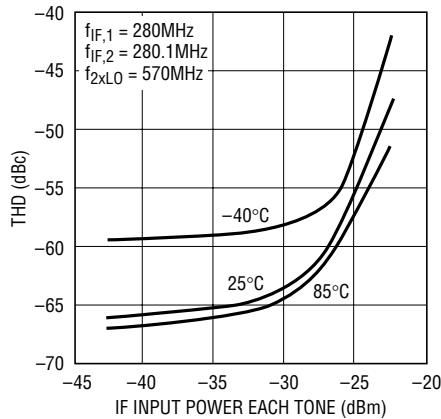

5506 G11

**LPF Frequency Response vs Baseband Frequency and Temperature**

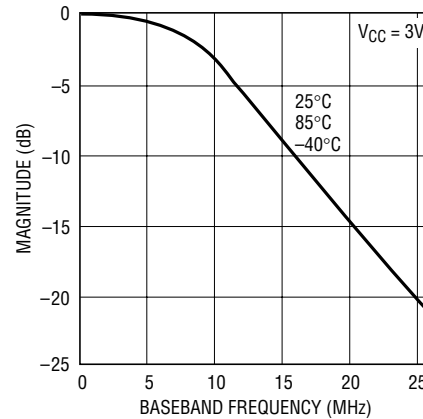

5505 G12

**LPF Frequency Response vs Baseband Frequency and Supply Voltage**

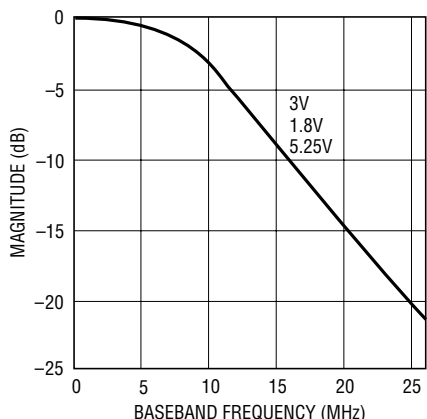

5505 G13

**IF Detector Output Voltage vs IF Input CW Power at 3V Supply**

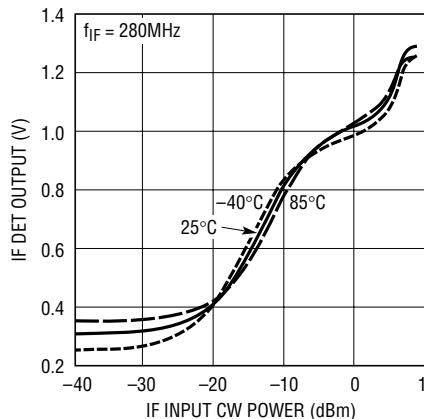

5506 G14

**IF Detector Output Voltage vs IF Input CW Power at 1.8V Supply**

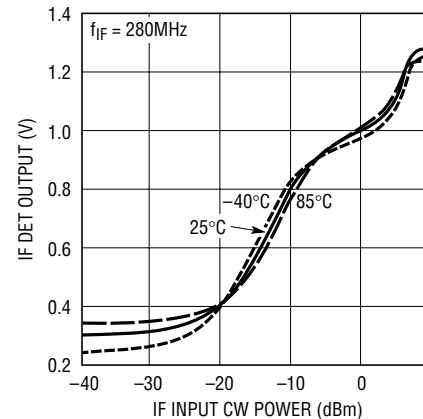

5506 G15

5506fa

**TYPICAL PERFORMANCE CHARACTERISTICS**  $V_{CC} = 3V$ ,  $f_{2 \times LO} = 570MHz$ ,  $P_{2 \times LO} = -5dBm$   
 (Note 5),  $f_{IF} = 284MHz$ ,  $P_{IF} = -30dBm$ , I and Q outputs 800mV<sub>P-P</sub> into 4k $\Omega$  differential load,  $T_A = 25^\circ C$ ,  $EN = V_{CC}$ ,  $STBY = V_{CC}$ ,  
 unless otherwise noted. (Note 3)

**IF Detector Output Voltage vs IF Input CW Power and Supply Voltage**

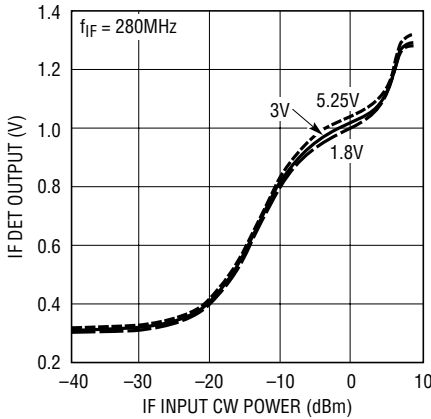

5506 G16

**IF Detector Output Voltage vs IF Input CW Power and IF Frequency**

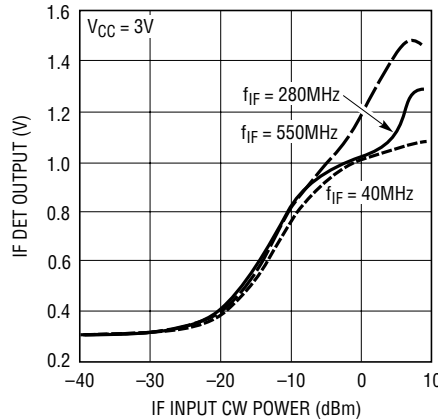

5506 G17

**Phase Relation Between I and Q Outputs vs LO Input Power**

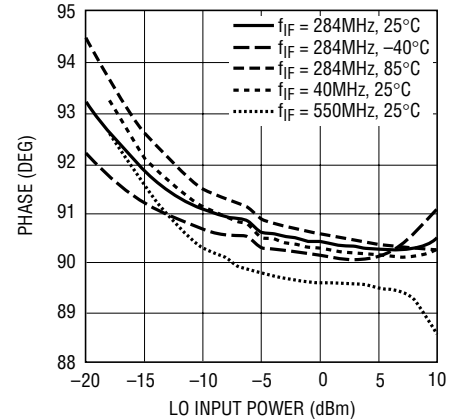

5506 G18

**PIN FUNCTIONS**

**GND (Pins 1, 4, 17):** Ground. Pins 1 and 4 are connected to each other internally. The Exposed Pad (Pin 17) is not connected internally to Pins 1 and 4. For chip functionality, the Exposed Pad and either Pin 1 or Pin 4 must be connected to ground. For best RF performance, Pin 1, Pin 4 and the Exposed Pad should be connected to RF ground.

**IF<sup>+</sup>, IF<sup>-</sup> (Pins 2, 3):** Differential Inputs for the IF Signal. Each pin must be DC grounded through an external inductor or RF transformer with central ground tap. This path should have a DC resistance lower than 2 $\Omega$  to ground.

**V<sub>CC</sub> (Pins 5 and 8):** Power Supply. These pins should be decoupled to ground using 1000pF and 0.1 $\mu$ F capacitors.

**V<sub>CTRL</sub> (Pin 6):** VGA Gain Control Input. This pin controls the IF gain and its typical input voltage range is 0.2V to 1.7V. It is internally biased via a 25k resistor to 0.2V, setting a low gain if the V<sub>CTRL</sub> pin is left floating.

**IF DET (Pin 7):** IF Detector Output. For strong IF input signals, the DC level at this pin is a function of the IF input signal level.

**EN (Pin 9):** Enable Input. When the enable pin voltage is higher than 1V, the IC is completely turned on. When the input voltage is less than 0.5V, the IC is turned off, except the part of the circuit associated with standby mode.

**2xLO<sup>-</sup>, 2xLO<sup>+</sup> (Pins 10, 11):** Differential Inputs for the 2xLO Input. The 2xLO input frequency must be twice that of the IF frequency. The internal bias voltage is V<sub>CC</sub> - 0.4V.

**STBY (Pin 12):** Standby Input. When the STBY pin is higher than 1V, the standby mode circuit is turned on to prebias the I/Q buffers. When the STBY pin is less than 0.5V, the standby mode circuit is turned off.

**Q<sub>OUT</sub><sup>-</sup>, Q<sub>OUT</sub><sup>+</sup> (Pins 13, 14):** Differential Baseband Outputs of the Q Channel. Internally biased at V<sub>CC</sub> - 1.19V.

**I<sub>OUT</sub><sup>-</sup>, I<sub>OUT</sub><sup>+</sup> (Pins 15, 16):** Differential Baseband Outputs of the I Channel. Internally biased at V<sub>CC</sub> - 1.19V.

## BLOCK DIAGRAM

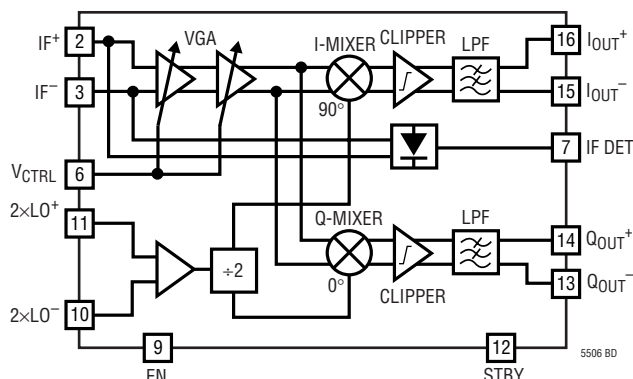

## APPLICATIONS INFORMATION

The LT5506 consists of variable gain amplifier (VGA), I/Q demodulator, quadrature LO generator, hard clipping amplifiers (clippers), lowpass filters (LPFs) and bias circuitry.

The IF signal is fed to the inputs of the VGA. The VGA gain is typically set by an external signal in such a way that the amplified IF signal delivered to the I/Q mixers is constant. The IF signal is then converted into I/Q baseband signals using the I/Q down-converting mixers. The quadrature LO signals that drive the mixers are internally generated from the on-chip divide-by-two circuit. The I/Q signals are passed through a pair of hard-clipping amplifiers (clippers), which protect the subsequent lowpass filters from overloading. After externally setting the required gain, these amplifiers should not clip. However, in the event of overload, they reduce the settling time of the (optional) external AC coupling capacitors by preventing asymmetrical charging and discharging effects. The second order baseband lowpass filters remove the out-of-band noise and harmonic content generated by the mixers and the clippers. The I/Q baseband outputs are buffered by output drivers.

### VGA and Input Matching

The VGA has a nominal 60dB gain control range with a frequency range of 40MHz to 500MHz. The inputs of the VGA must have a DC return to ground. This can be done using a transformer with a central tap (on secondary) or an LC matching circuit with a matched impedance at the frequency of interest and near zero impedance at DC. The

differential AC input impedance of the LT5506 is about 200Ω, thus a 1:4 (impedance ratio) RF transformer with central tap can be used. In Figure 6, the evaluation board schematic is shown using a 1:4 transformer. The measured input sensitivity of this board is about -82.6dBm for a 10dB signal-to-noise ratio. In the case of an LC matching circuit, the circuit of Figure 1 can be used. In Table 1 the values are given for a range of IF frequencies. The matching circuit of Figure 1 approaches 180° phase shift between IF<sup>+</sup> and IF<sup>-</sup> in a broad range around its center frequency. However, some amplitude mismatch occurs if the circuit is not tuned to the center frequency. This leads to reduced circuit linearity performance, because one of the inputs carries a higher signal compared to the perfectly balanced case. A 10% frequency shift from the center frequency results in about a 2dB gain difference between the IF<sup>+</sup> and IF<sup>-</sup> inputs. This results in a 1.5dB higher IM3 contribution from the input stage which leads to a 0.75dB drop in IIP3. Moreover, the IIP2 of the circuit is also reduced which can lead to a higher second order harmonic contribution. The circuit can be driven single ended, but this is not recommended because it leads to a 3dB drop in gain and a considerable increase in IM5 and IM7 components. The single-ended noise figure increases by 4dB if one IF input is directly grounded and increases by 1.5dB if one IF input is grounded via a 1μH inductor. An IF input cannot be left open or connected via a resistor to ground because this will disturb the internal biasing, reducing the gain, noise and linearity performance. For optimal performance, it is important to keep the DC impedance to ground



APPLICATIONS INFORMATION

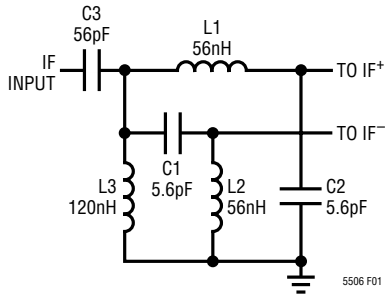

Figure 1. IF Input Matching Network at 280MHz

Table 1. The Component Values of Matching Network L1, L2, L3, C1, C2 and C3.

$f_{IF}$ (MHz)	L1, L2(nH)	C1, C2(pF)	L3(nH)	C3(pF)
50	340	34	1800	820
100	159	15.9	470	220
150	106	10.6	470	220
200	80	8.0	470	220
250	64	6.4	120	56
300	53	5.3	120	56
350	45	4.5	120	56
400	40	4.0	120	56
450	35	3.5	120	56
500	32	3.2	120	56

of both IF inputs lower than  $2\Omega$ . In the matching network of Figure 1, inductor L3 is used for supplying the DC bias current to the IF<sup>+</sup> input. To keep the DC resistance of L3 below  $2\Omega$ , 120nH is used. This disturbs the matching network slightly by causing the frequency where the S11 is minimal to be lower than the frequency where the amplitudes of IF<sup>+</sup> and IF<sup>-</sup> are equal. To compensate for this, the value of coupling capacitor C3 is lowered and will contribute some correcting reactance. For low frequencies, it might not be possible to find any practical inductor value for L3 with DC resistance smaller than  $2\Omega$ . In that case it is recommended to use a transformer with central tap. The tolerance for the components in Figure 1 can be 10% for a return loss higher than 16dB and a gain reduction due to mismatch less than 0.3dB.

It is possible to simplify the input matching circuit and compromise the performance. In Figure 2a, the simplified matching network is given.

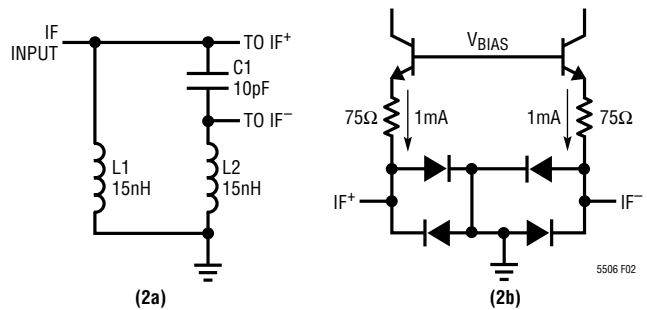

Figure 2a. Simplified IF Input Matching Network at 280MHz and Figure 2b. Simplified Circuit Schematic of the IF Inputs

This matching network can deliver equal amplitudes to the IF<sup>+</sup> and IF<sup>-</sup> inputs for a narrow frequency region, but the phase difference between the inputs will not be exactly 180 degrees. In practice, the phase shift will be around 145 degrees, depending on the quality factor of the network. This will result in a reduction in the gain. The higher the chosen quality factor, the closer the phase difference will approach 180 degrees. However, a higher quality factor will reduce bandwidth and create more loss in the matching network. For minimum board space, 0402 components are used. The measured noise figure for maximum gain with this matching network is about 8dB, and the maximum gain about 57dB. Assuming 0402 inductors with  $Q = 35$ , the insertion loss of this network is about 2.5dB. The tolerance for the components in Figure 2a can be 10% for a return loss higher than 10dB and a gain reduction due to mismatch less than 0.5dB. The measured input sensitivity for this matching network (see also Figure 11) is about  $-82.7\text{dBm}$  for a 10dB signal-to-noise ratio.

The gain of the VGA is set by the voltage at the V<sub>CTRL</sub> pin. For high gain settings, both the noise figure and the input IP3 will be low. From a noise figure point of view, it is advantageous to work as closely as possible to the maximum gain point. However, if the voltage at the V<sub>CTRL</sub> pin is increased beyond the maximum gain point (where additional increase in control voltage does not give an increase in gain), the response time of the gain control circuit is increased. If control speed is crucial, a few dB of gain margin should be allowed from the highest gain point to be sure that at all temperatures, the maximum gain setting is not crossed. At low gain settings, the noise figure and the input IP3 will be high. Optionally, the control



## APPLICATIONS INFORMATION

voltage  $V_{CTRL}$  can be set lower than 0.2V. The normal range is from  $V_{CTRL} = 0.2V$  to 1.7V, which results in a nominal gain range from 0.9dB to 59dB. The linear-in-dB gain relation with the  $V_{CTRL}$  voltage still holds for control voltages as low as  $-0.4V$ . This results in an extended gain control range of  $-19.7dB$  to 59dB. The  $V_{CTRL}$  pin is a very sensitive input because of its high input impedance and therefore should be well shielded. Signal pickup on the  $V_{CTRL}$  pin can lead to spurs and increased noise floor in the I/Q baseband outputs. It can degrade the linearity performance and it can cause asymmetry in the two-tone test. If control speed is not important,  $1\mu F$  bypass capacitors are recommended between  $V_{CTRL}$  and ground.

A fast responding peak detector is connected to the VGA input, sensitive to signal levels above the signal levels where the VGA is operating in the linear range. It is active from  $-22dBm$  up to  $5dBm$  IF input signal levels. The DC output voltage of this detector (IF DET) can be used by the baseband controller to quickly determine the presence of a strong input level at the desired channel, and adjust gain accordingly. Figure 3a shows the simplified circuit schematic of the IF DET output.

### I/Q Demodulators

The quadrature demodulators are double balanced mixers, down-converting the amplified IF signal from the VGA into I/Q baseband signals. The quadrature LO signals are generated internally from a double frequency external CW signal. The nominal output voltage of the differential I/Q baseband signals should be set to  $0.8V_{P-P}$  or lower, depending on the linearity requirements. The magnitudes of I and Q are well matched and their phases are  $90^\circ$  apart.

### Quadrature LO Generator

The quadrature LO generator consists of a divide-by-two circuit and LO buffers. An input signal (2xLO) with twice the desired IF signal frequency is used as the clock for the divide-by-two circuit, producing the quadrature LO signals for the demodulators. The outputs are buffered and then drive the down-converting mixers. With a fully differential approach, the quadrature LO signals are well matched. Second harmonic content (or higher order even harmonics) in the external 2xLO signal can degrade the  $90^\circ$  phase shift between I and Q. Therefore, such content should be

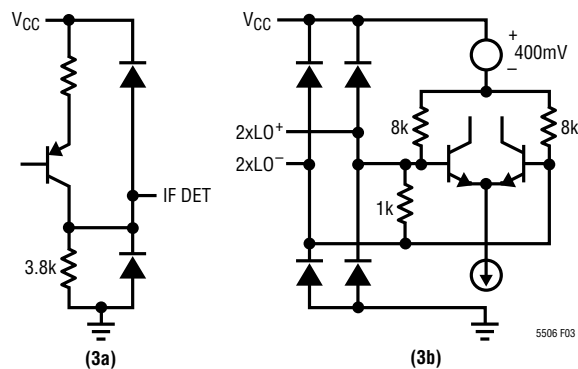

Figure 3a. Simplified Circuit Schematic of the IF DET Output and Figure 3b. The 2xLO Inputs

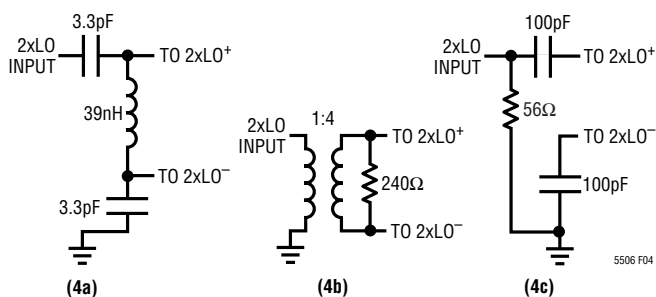

Figure 4. 2xLO Input Matching Networks for 4a) Narrow Band Tuned to 570MHz, 4b) Wide Band, 4c) Single-Ended Wide Band

minimized. Figure 3b shows the simplified circuit schematic of the 2xLO inputs. Depending on the application, different 2xLO input matching networks can be chosen. In Figure 4, three examples are given. The first network provides the best 2xLO input sensitivity because it can boost up the 2xLO differential input signal using a narrow-band resonant approach. The second network gives a wide-band match, but the 2xLO input sensitivity is about 2dB lower. The third network gives a simple and less expensive wide-band match, but 2xLO input sensitivity drops by about 9dB. The IF input sensitivity doesn't change significantly using either of the three 2xLO matching networks.

### Baseband Circuit

The baseband circuit consists of I/Q hard limiters (clippers), I/Q lowpass filters and I/Q output buffers. The hard limiter operates as a linear amplifier normally. However, if a high level input temporarily overloads the linear amplifier, then the circuit will limit symmetrically, which will help to prevent the filter and output buffer from overloading. This speeds up recovery from an overload event,

5506fa

## APPLICATIONS INFORMATION

which can occur during the gain settling. It also helps to reduce the high frequency spectral content at the I/Q outputs during overload. The second order integrated lowpass filters are used for filtering the down-converted baseband signals for both the I channel and the Q channel. They serve as antialiasing and pulse-shaping filters. The I/Q filters are well matched in gain response and group delay. The 3dB corner frequency is typically 8.8MHz with a group delay ripple of 5ns. The I/Q outputs can drive 2kΩ in parallel with a maximum capacitive loading of 10pF, from all four pins to ground. The outputs are internally biased at  $V_{CC} - 1.19V$ . Figure 5 shows the simplified output circuit schematic of the I channel or Q channel.

The I/Q baseband outputs can be DC-coupled to the inputs of a baseband chip. For AC-coupled applications with large capacitors, the STBY pin can be used to pre-bias the outputs to nominal  $V_{CC} - 1.19V$  at much reduced current. This mode draws only 3.6mA supply current. When the EN pin is then driven high (>1V), the chip is quickly switched to normal operating mode, avoiding the introduction of large charging time constants. Table 2 shows the logic of

**Table 2. The Logic of Different Operating Modes**

EN	STBY	Comments
Low	Low	Shutdown Mode
Low	High	Standby Mode
High	Low or High	Normal Operation Mode

the EN pin and STBY pin. In both normal operating mode and standby mode, the maximum discharging current is about 300μA, and the maximum charging current is more than 4mA. In Figure 5 the simplified circuit schematic of the STBY (or EN) input is shown.

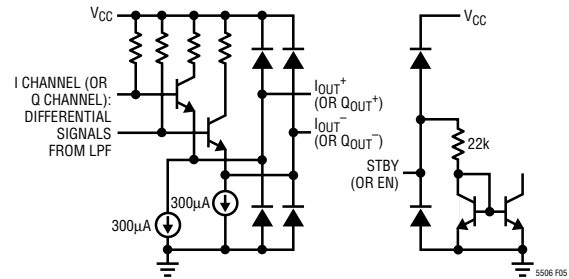

**Figure 5. Simplified Circuit Schematic of I Channel (or Q Channel) Outputs and STBY (or EN) Input**

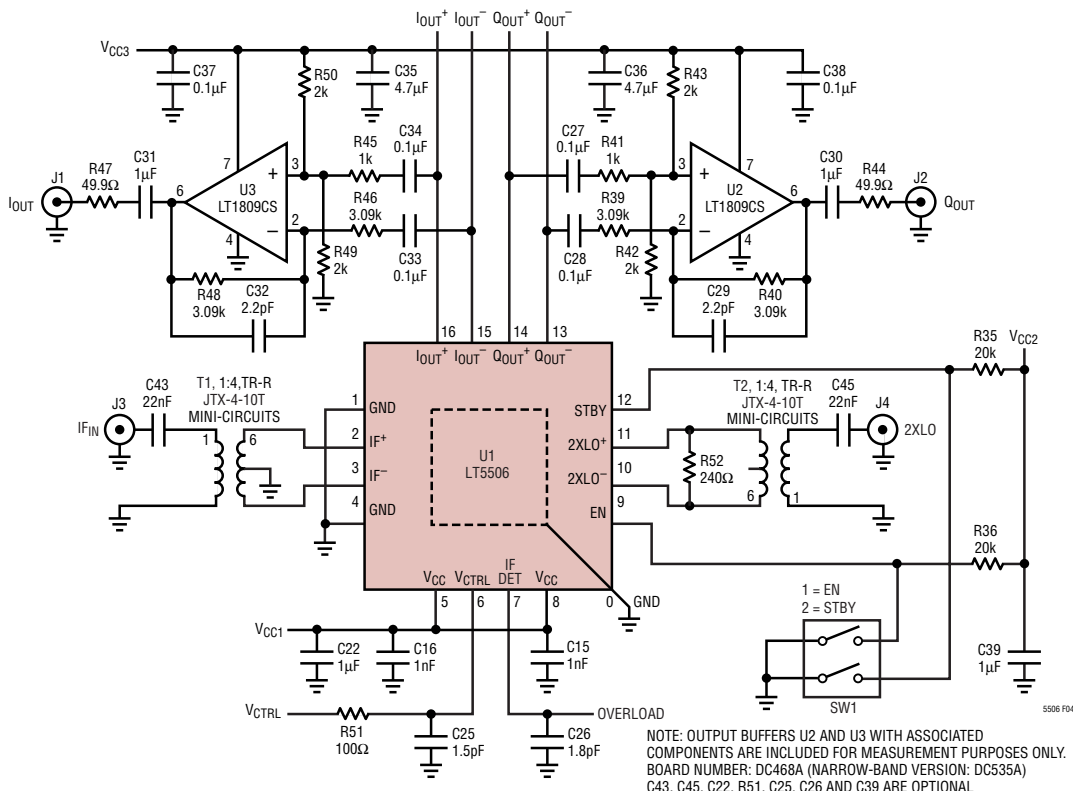

**Figure 6. Evaluation Circuit Schematic with I/Q Output Buffers**



APPLICATIONS INFORMATION

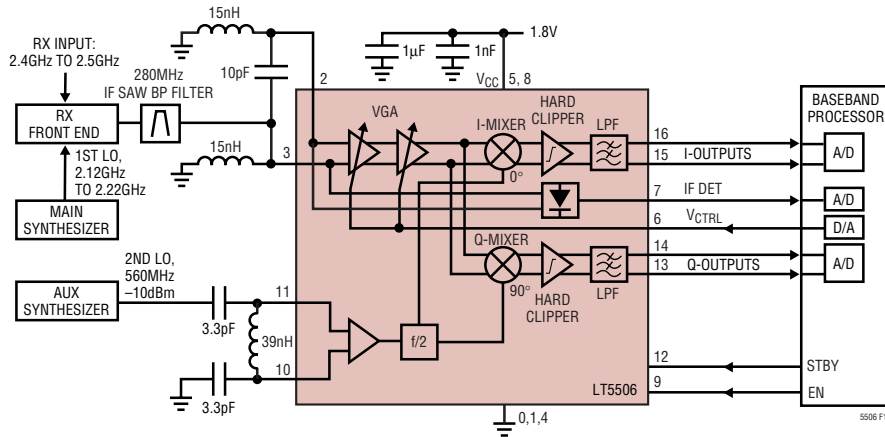
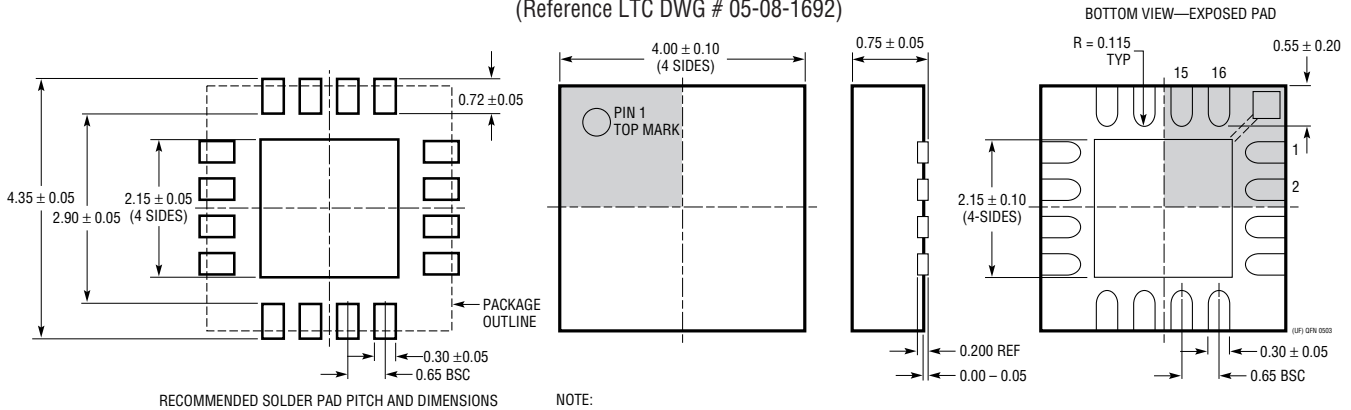

Figure 11. 2.4GHz to 2.5GHz Receiver Application (RX IF = 280MHz)

PACKAGE DESCRIPTION

UF Package  
 16-Lead Plastic QFN (4mm × 4mm)  
 (Reference LTC DWG # 05-08-1692)



- NOTE:
1. DRAWING CONFORMS TO JEDEC PACKAGE OUTLINE MO-220 VARIATION (WGCC)
  2. ALL DIMENSIONS ARE IN MILLIMETERS
  3. DIMENSIONS OF EXPOSED PAD ON BOTTOM OF PACKAGE DO NOT INCLUDE MOLD FLASH. MOLD FLASH, IF PRESENT, SHALL NOT EXCEED 0.15mm ON ANY SIDE
  4. EXPOSED PAD SHALL BE SOLDER PLATED

RELATED PARTS

PART NUMBER	DESCRIPTION	COMMENTS
LT5500	1.8GHz to 2.7GHz Receiver Front End	1.8V to 5.25V Supply, Dual-Gain LNA, Mixer
LT5502	400MHz Quadrature IF Demodulator with RSSI	1.8V to 5.25V Supply, 70MHz to 400MHz IF, 84dBm Limiting Gain, 90dB RSSI Range
LT5503	1.2GHz to 2.7GHz Direct IQ Modulator and Mixer	1.8V to 5.25V Supply, Four Step RF Power Control, 120MHz Modulation Bandwidth
LT5504	800MHz to 2.7GHz RF Measuring Receiver	2.7V to 5.25V Supply, 80dB Dynamic Range, Temperature Compensated
LTC5505	RF Power Detectors with >40dB Dynamic Range	2.7V to 6V Supply, 300MHz to 3.5GHz, Temperature Compensated
LTC5507	100kHz to 1000MHz RF Power Detector	2.7V to 6V Supply, 40dB Dynamic Range, Temperature Compensated
LT5511	High Signal Level Upconverting Mixer	RF Output to 3GHz, 17dBm IIP3, Integrated LO Buffer
LT5512	High Signal Level Downconverting Mixer	DC-3GHz, 21dBm IIP3, Integrated LO Buffer

5506fa