

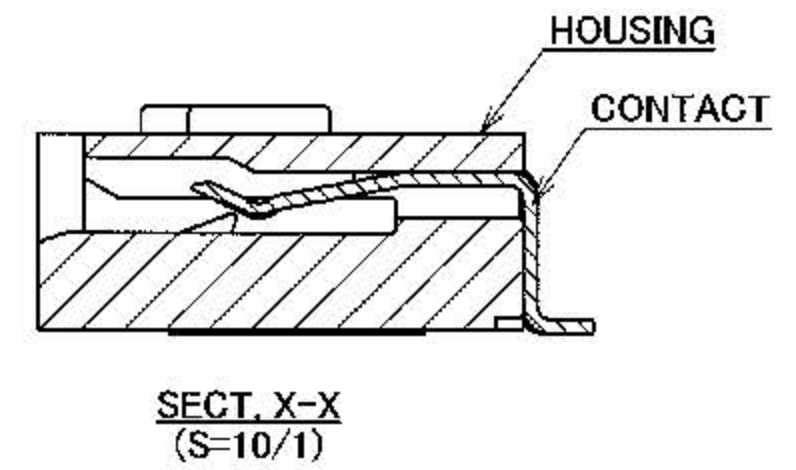

PART NO.	POS.	A	B	C	D	E
◆20526-030E-01	30	28.10	20.90	14.50	26.40	18.56
20526-040E-01	40	33.10	25.90	19.50	31.40	23.56
◆20526-045E-01	45	35.60	28.40	22.00	33.90	26.06
20526-050E-01	50	38.10	30.90	24.50	36.40	28.56
20526-060E-01	60	43.10	35.90	29.50	41.40	33.56

◆MARK MEANS NOT AVAILABLE

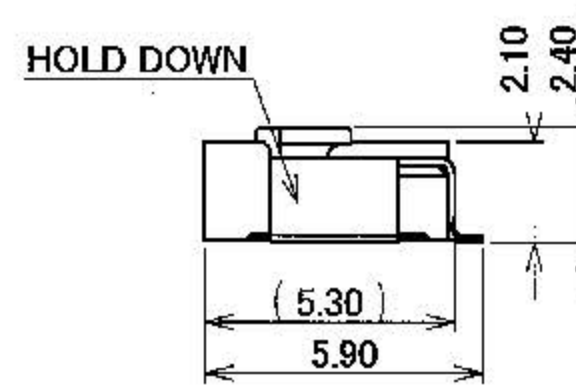
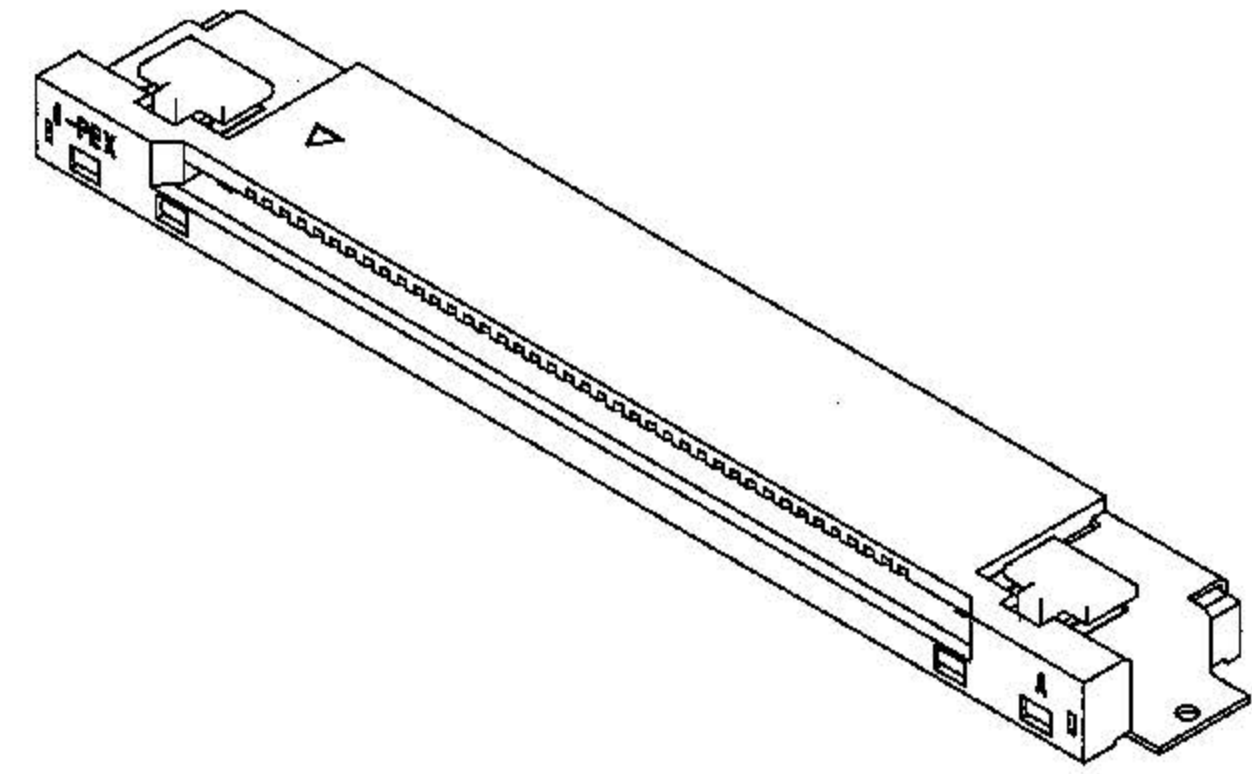
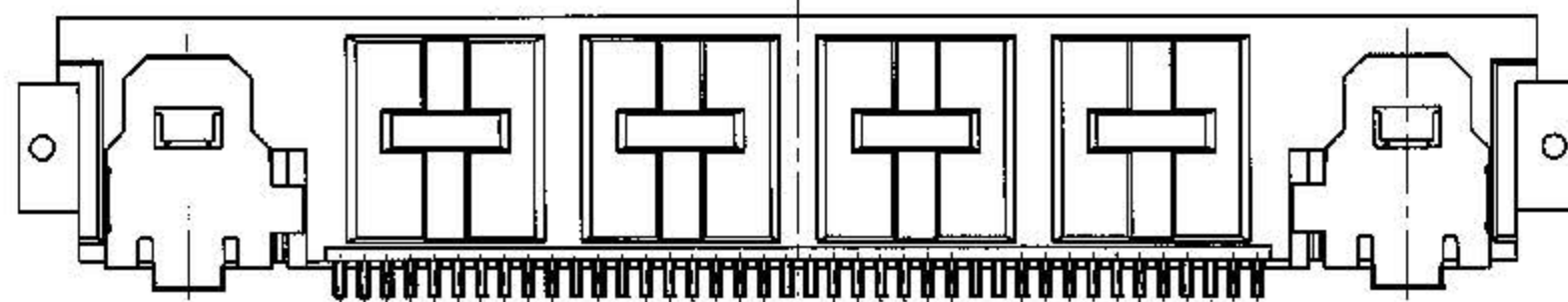
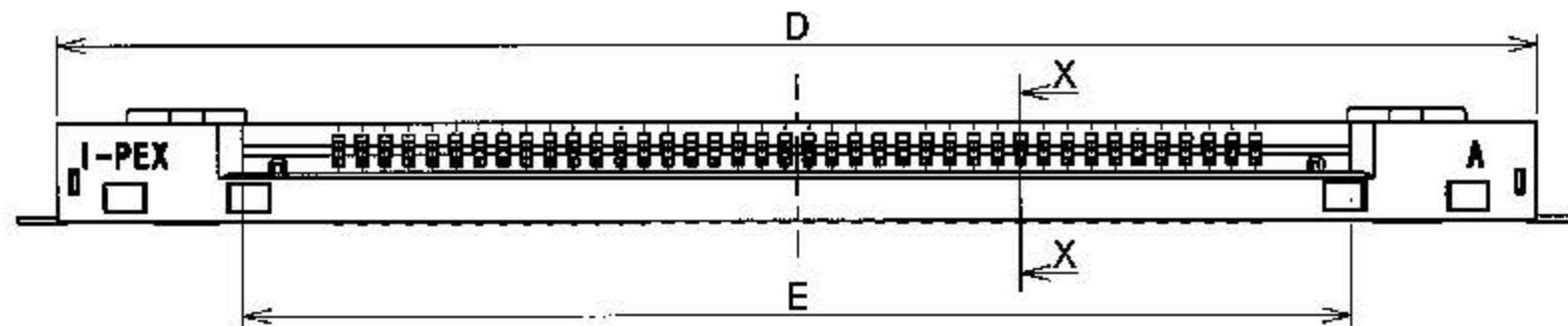
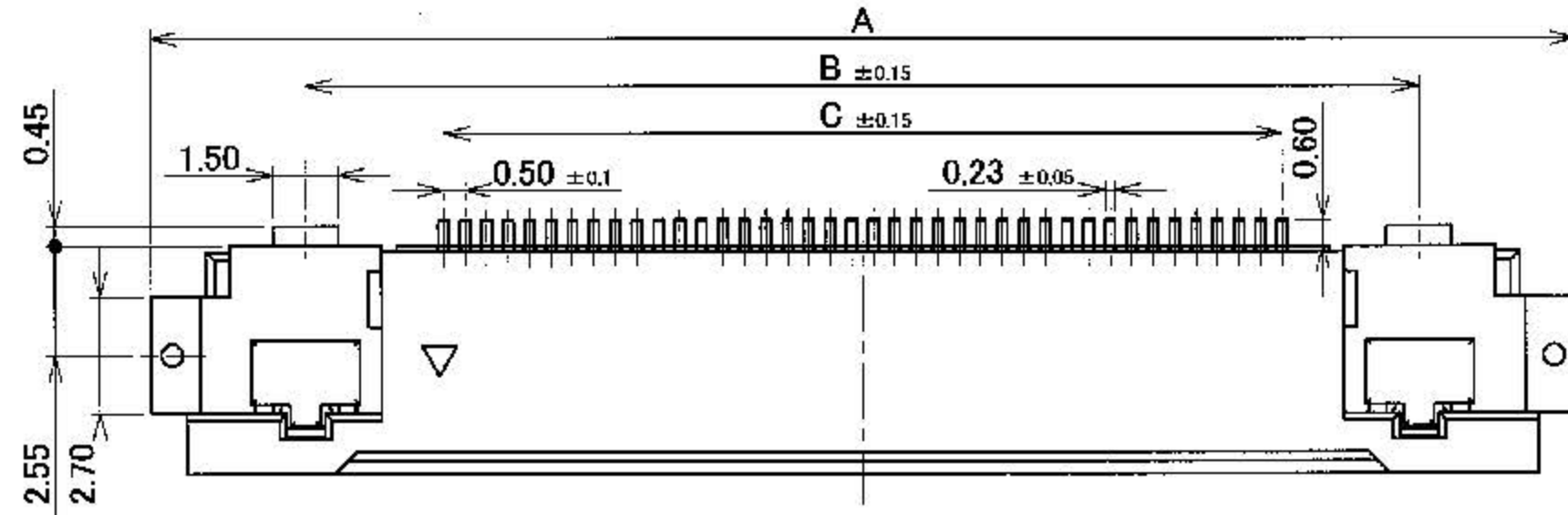

- NOTES.
- MATERIAL
    - HOUSING : LCP UL94V-0 BLACK
    - CONTACT : COPPER ALLOY
    - HOLD DOWN : COPPER ALLOY
  - FINISH
    - CONTACT : Au OVER Ni
    - HOLD DOWN : Sn OVER Ni
  - PRODUCT SPECIFICATION No.PRS-1562  
INSTRUCTION MANUAL No.JER-001-04174
  - COPLANARITY : 0.1 MAX.
  - RoHS Compliant

GENERAL TOLERANCE	
6 MAX.	±0.2
6 OVER MAX. 30	±0.3
30 OVER MAX. 120	±0.5
ANGLE	±2°

DESIGN'D BY <i>H. Hara</i>				DATE Nov. 05/10		 Interconnect and Packaging Electronics TOKYO, JAPAN			
CHK'D BY <i>Y. Hara</i>				DATE Nov. 05/10					
APP'D BY <i>J. Hara</i>				DATE Nov. 09/10		TITLE EVAFLEX5-SE			
REV	ECN	BY	DATE	APP	SCALE	UNIT	DWG. No.	SHEET	REV.
0	Z1046	h.h	Nov. 05/10			mm	20526	1/2	0
REV.RECORD				CUSTOMER COPY		PROJECTION			
SERIES No.									

PART NO.	POS.	B	C	F	G	H
◆20526-030E-01	30	20.90	14.50	18.50	15.50	27.00
20526-040E-01	40	25.90	19.50	23.50	20.50	32.00
◆20526-045E-01	45	28.40	22.00	26.00	23.00	34.50
20526-050E-01	50	30.90	24.50	28.50	25.50	37.00
20526-060E-01	60	35.90	29.50	33.50	30.50	42.00

◆MARK MEANS NOT AVAILABLE

### RECOMMENDED FFC/FPC LAYOUT

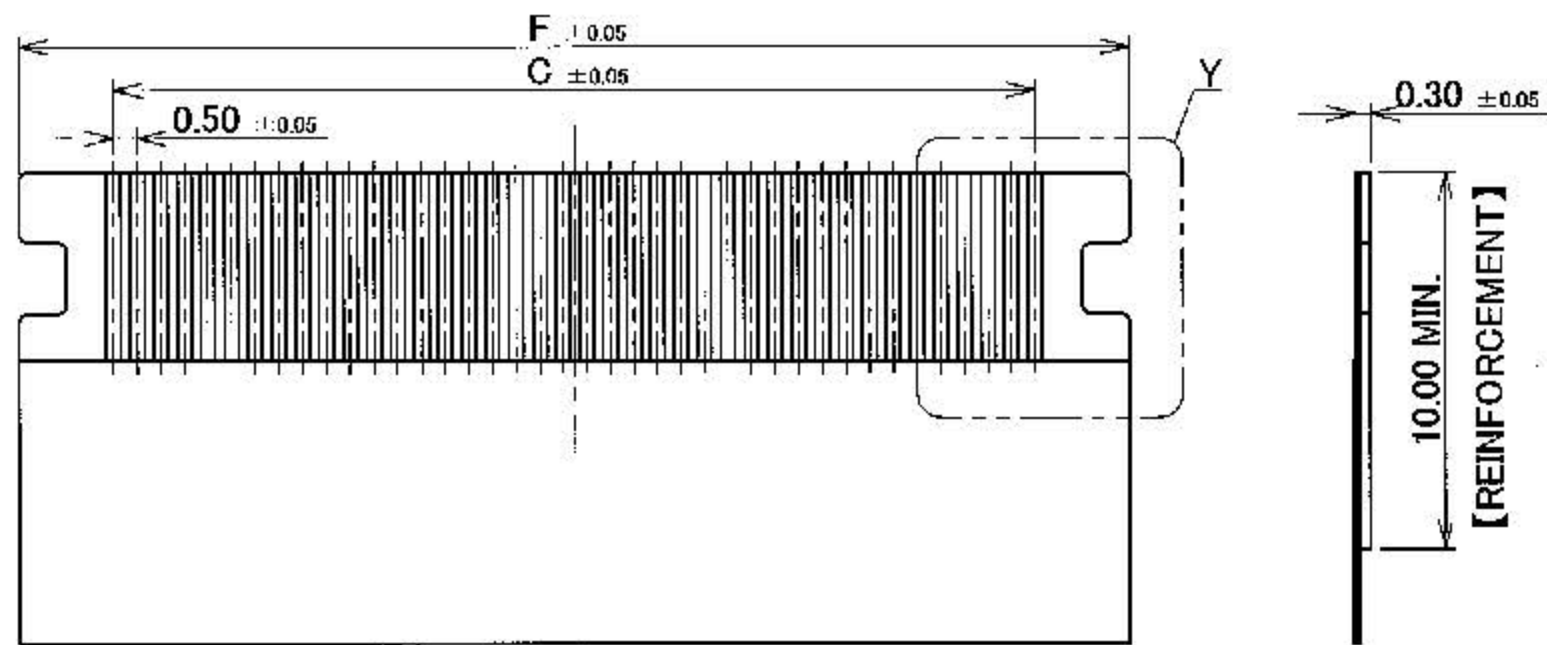

### RECOMMENDED PCB LAYOUT

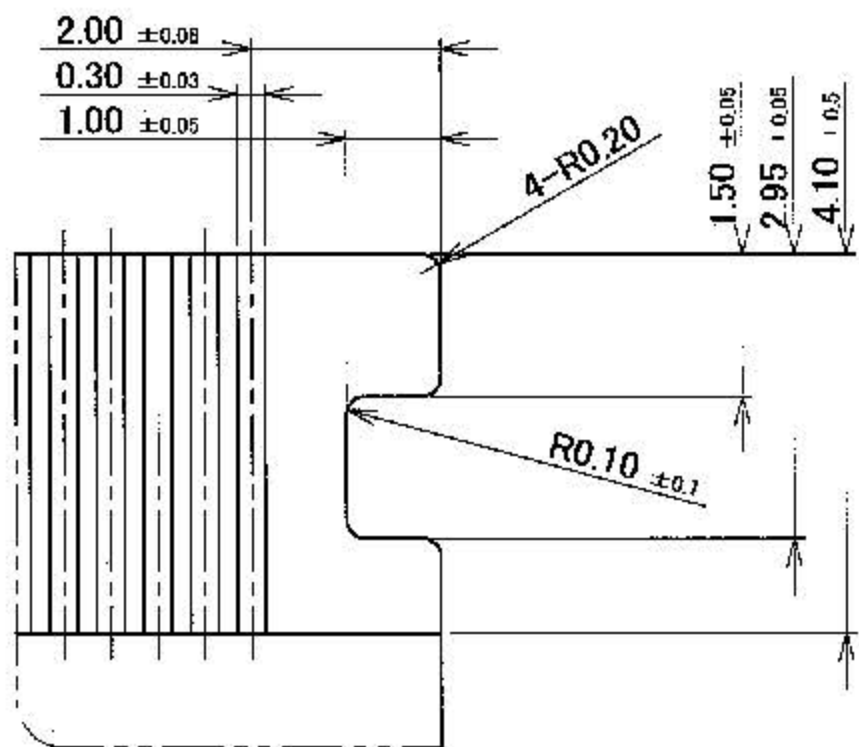
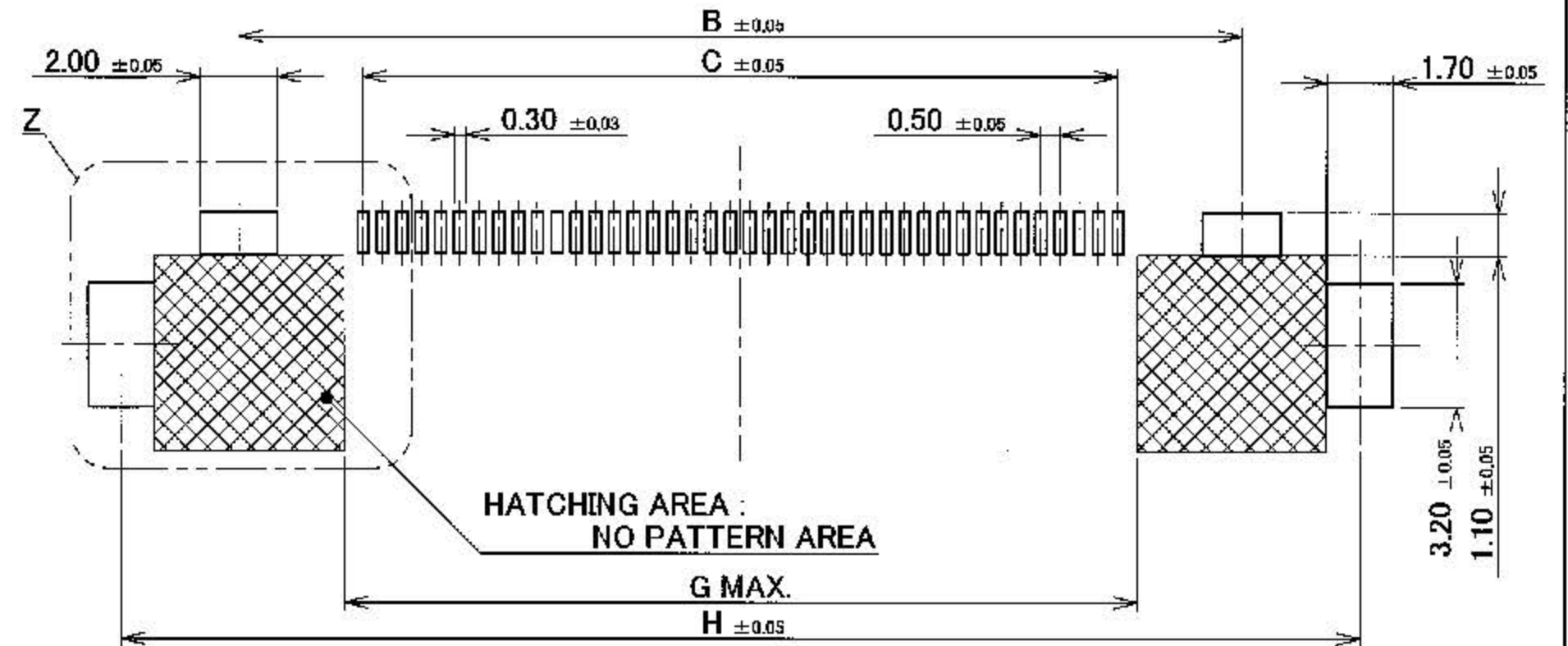

DETAIL Y  
(S=10/1)

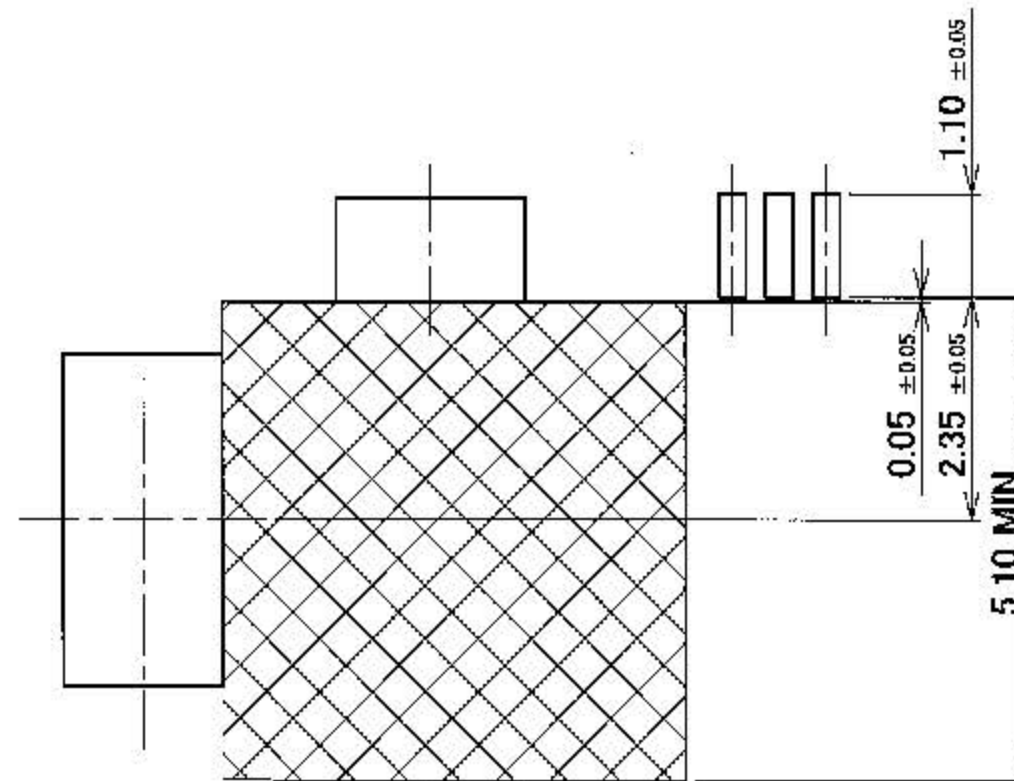

DETAIL Z  
(S=10/1)

GENERAL TOLERANCE	
6 MAX.	$\pm 0.2$
6 OVER MAX. 30	$\pm 0.3$
30 OVER MAX. 120	$\pm 0.5$
ANGLE	$\pm 2^\circ$

DESIGN'D BY	DATE	<b>I-PEX</b> Interconnect and Packaging Electronics TOKYO, JAPAN	TITLE								
CHK'D BY	DATE		EVAFLEX5-SE								
APP'D BY	DATE		SCALE	L/VIT	DWG. No.						
REV	ECN	BY	DATE	APP	CUSTOMER COPY	PROJECTION	5:1	mm	20526	SHEET	REV.
REV. RECORD					CUSTOMER COPY	PROJECTION	5:1	mm	20526	2/2	0
SERIES No.											