

芯伯乐®  
X I N B O L E

# Product Specification

XBLW MAX1044

DC / DC Voltage Conversion

WEB | [www.xinboleic.com](http://www.xinboleic.com)



## Description

MAX1044 is a single chip DC/DC voltage conversion integrated circuit manufactured by a special process. It has the output of reverse, double voltage, partial voltage and multiple voltage. It can work stably in the range of 1.5V~9.0V, and does not need any diode in the whole temperature range. 10mA of current can be released for every 0.5V voltage drop. With the BOOST input, the oscillator frequency can be raised above the audio band, reducing the output ripple, and therefore, reducing the size of the external capacitor capacity. Combining low static current and high conversion efficiency, the chip has a built-in oscillator control circuit and four power MOSFET conversion switches. Applications include: negative voltage generation, voltage doubling generation, and input voltage 1/2 partial voltage. The series of products are widely used in data acquisition system, portable instrument and other electronic products.

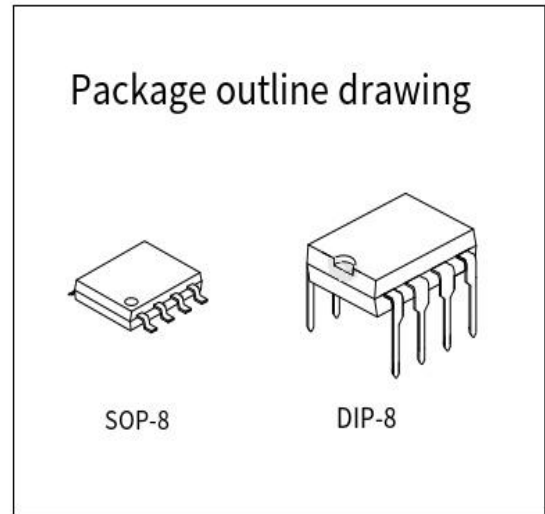

## Features

- Input voltage: 1.5V ~ 9.0V
- Low static current typ.=65uA @5V
- 98% power conversion efficiency
- Invert, double voltage, partial voltage and multiple voltage
- BOOST pins are used to increase the oscillation frequency
- Package: DIP8, SOP8

## Application

- Dual power supply operational amp power supply
- Data acquisition system
- PDA
- Can be used as voltage converter, voltage divider
- Portable meter

## Ordering information

Product Model	Package Type	Marking	Packing	Packing Qty
MAX1044EPA	DIP-8	MAX1044	Tube	2000Pcs/Box
MAX1044ESA	SOP-8	MAX1044	Tape	2500Pcs/Reel

## Package form and pin define function

SOP-8

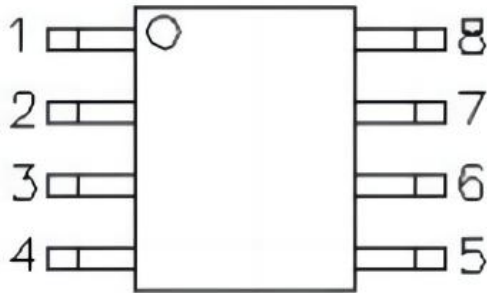

DIP-8

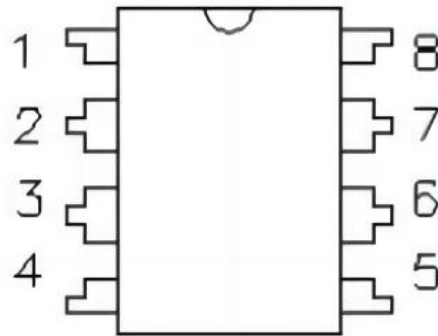

Pin number	Pin definition	Pin number	Pin definition
1	BOOST	2	CAP+
3	GND	4	CAP-
5	VOUT	6	LV
7	OSC	8	V+

Name	Pin number	Function Description
BOOST	1	Raise the frequency control end. Connecting BOOST and V+ increases the frequency of the internal oscillator by a factor of 6. If using an external oscillator, the BOOST will do nothing and it should be suspended at this point.
CAP+	2	Connect to the negative terminal of the charge pump capacitor.
GND	3	Be grounded. In most applications, the negative end of the accumulator capacitor should be connected to this pin.
CAP-	4	Connect to the positive terminal of the charge pump capacitor.
VOUT	5	Positive voltage output end. In most applications, the positive end of the accumulator capacitor should be connected to this pin.
LV	6	Low voltage operation select section. This end should be connected to ground when the supply voltage is below 3.5V.
OSC	7	Oscillator frequency control input. An external capacitor reduces the frequency of the internal oscillator.
V+	8	Power supply positive voltage input (1.5~9V), V+ is also the chip substrate connection point.

## Typical application

Negative voltage conversion (using BOOST and COSC)

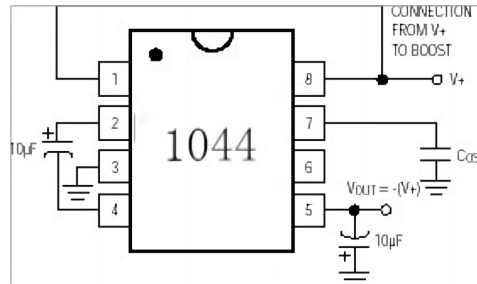

Negative voltage conversion (using BOOST and LV)

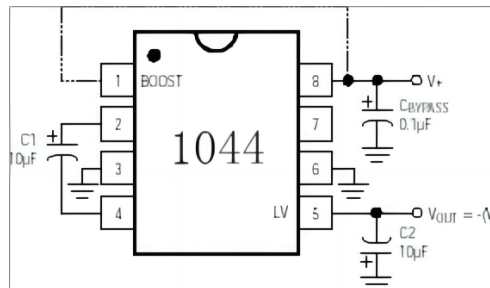

Voltage doubler output circuit

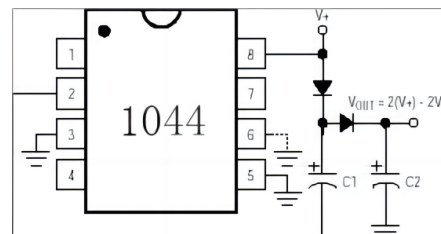

### Limit parameters

Items	Symbols	Parameters	Limit values	Units
Voltage	V+	Input voltage V+ to GND	9	V
	Vout	The output voltage is GND to VOUT	9	V
	Vin	Pin6/Pin7 Port input voltage	-0.3 ~V+ +0.3	V
Current	ILV	LV port input current	20	uA
Temperature	TA	Operating temperature	- 20 ~ 85	°C
	TS	Storage temperature	- 65-150	°C
	TW	Pin welding temperature	260, 10s	°C

Note:

The limit parameter refers to the limit value that cannot be exceeded under any conditions. If this limit value is exceeded, it may cause physical damage such as product deterioration; At the same time, it is not guaranteed that the chip can work normally when it is close to the limit parameter.

### Electrical characteristics unless otherwise specified

V+ = 5.0V, LVpin = 0V, BOOSTpin = open, ILOAD = 0mA, TA = TMIN ~ TMAX

Parameters	Test conditions	Min	Typ	Max	unit
Power supply current	RL = +∞, connect Pin1 and Pin7, LV open	TA = +25°C	30	180	μA
		TA = 0°C ~ +70°C		200	
		TA = -20°C ~ +85 °C		200	
	RL = +∞, Pin 1 = Pin 7 = V+ = 3V		10		
Supply voltage range	RL = 10KΩ, LV open				V
	RL = 10KΩ, LV to GND	1.5		10	
Power supply current	IL = 20mA, fOSC = 5kHz, LV open	TA = +25°C	65	100	Ω
		TA = 0°C ~ +70°C		130	
		TA = -20°C ~ +85 °C		130	
Power supply current	fOSC = 1kHz, V+ = 2V, IL = 3mA, LV to GND	TA = +25°C		325	Ω
		TA = 0°C ~ +70°C		325	
		TA = -20°C ~ +85 °C		325	
Oscillator frequency	COSC = 1pF, LV to GND	V+ = 5V	5		kHz
		V+ = 2V	1		
Power supply power	RL = 5kΩ, TA = +25°C, fOSC = 5kHz, LV open	95	98		%
Voltage reversal power	RL = +∞, TA = +25 °C, LV open	97.0	99.9		%
Oscillator source drain current	VOSC = 0V or V+, LV open	Pin 1 = 0v		3	M Ω
		Pin 1 = V+		20	
Oscillator impedance	TA = +25°C	V+ = 5V	1000		K Ω
		V+ = 2V	100		

## Package Outline Dimensions

### SOP-8

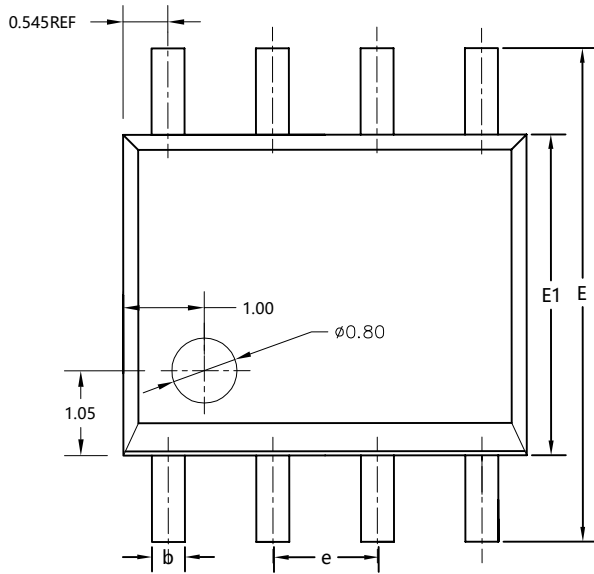
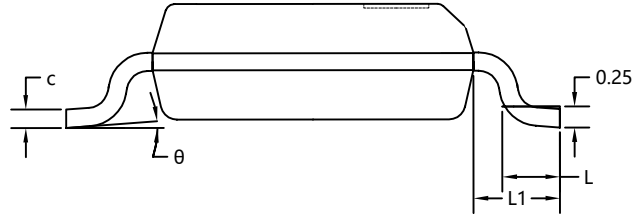
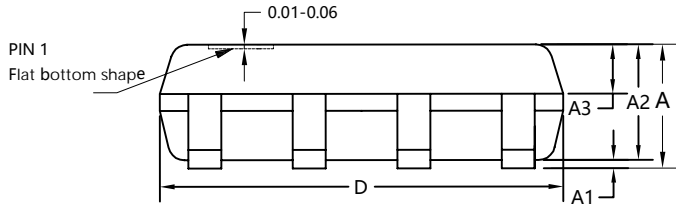

SYMBOL	MILLIMETER		
	MIN	NOM	MAX
A	1.55	1.65	1.75
A1	0.10	0.15	0.20
A2	1.35	1.45	1.55
A3	0.60	0.70	0.80
b	0.30	0.40	0.50
c	0.17	0.20	0.25
D	4.80	4.90	5.00
E	5.80	6.00	6.20
E1	3.80	3.90	4.00
e	1.27BSC		
L	0.50	0.60	0.70
L1	1.05REF		
$\theta$	0°	4°	8°

DIP-8

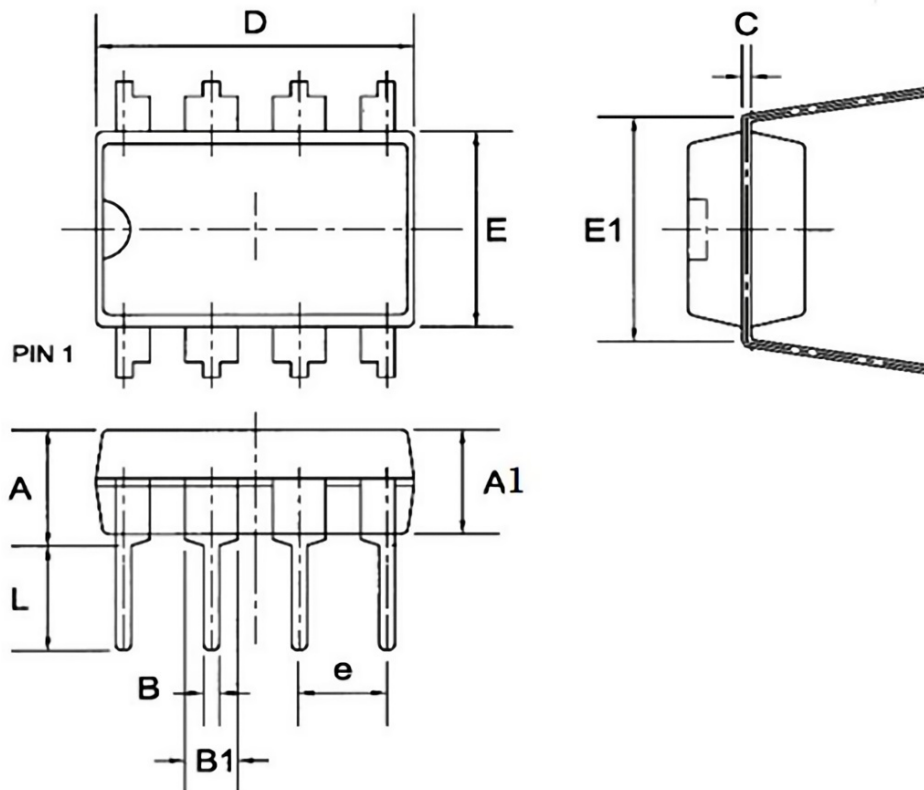

Symbol	Dimensions in Millimeters		
	Min	Nom	Max
A	--	--	4.31
A1	3.15	3.30	3.65
B	0.38	0.46	0.51
B1	1.27	1.55	1.77
C	0.20	0.25	0.30
D	8.95	9.40	9.45
E	6.15	6.20	6.65
E1	--	7.60	--
e	--	2.54	--
L	3.00	3.30	3.60

## Statement:

- XBLW reserves the right to modify the product manual without prior notice! Before placing an order, customers need to confirm whether the obtained information is the latest version and verify the completeness of the relevant information.
- Any semi-guide product is subject to failure or malfunction under specified conditions. It is the buyer's responsibility to comply with safety standards when using XBLW products for system design and whole machine manufacturing. And take the appropriate safety measures to avoid the potential in the risk of loss of personal injury or loss of property situation!
- XBLW products are not licensed for life support, military, aerospace and other applications, and XBLW will not be responsible for the consequences of the use of products in these fields.
- If any or all XBLW products (including technical data, services) described or contained in this document are subject to any applicable local export control laws and regulations, they may not be exported without an export license from the relevant authorities in accordance with such laws.
- The specifications of any and all XBLW products described or contained in this document specify the performance, characteristics, and functionality of said products in their standalone state, but do not guarantee the performance, characteristics, and functionality of said products installed in Customer's products or equipment. In order to verify symptoms and conditions that cannot be evaluated in a standalone device, the Customer should ultimately evaluate and test the device installed in the Customer's product device.
- XBLW documentation is only allowed to be copied without any alteration of the content and with the relevant authorization. XBLW assumes no responsibility or liability for altered documents.
- XBLW is committed to becoming the preferred semiconductor brand for customers, and XBLW will strive to provide customers with better performance and better quality products.