

THIS DOCUMENT IS THE PROPERTY OF
KEYSTONE ELECTRONICS CORP. AND
SHALL NOT BE REPRODUCED, DISTRIBUTED
OR USED AS A BASIS FOR MANUFACTURE
WITHOUT PRIOR WRITTEN PERMISSION
FROM KEYSTONE ELECTRONICS CORP.

ACTUAL SIZE

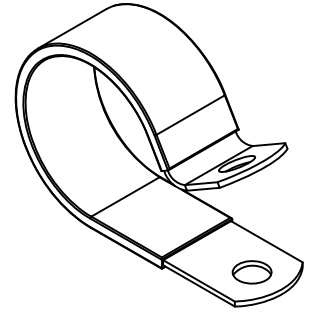
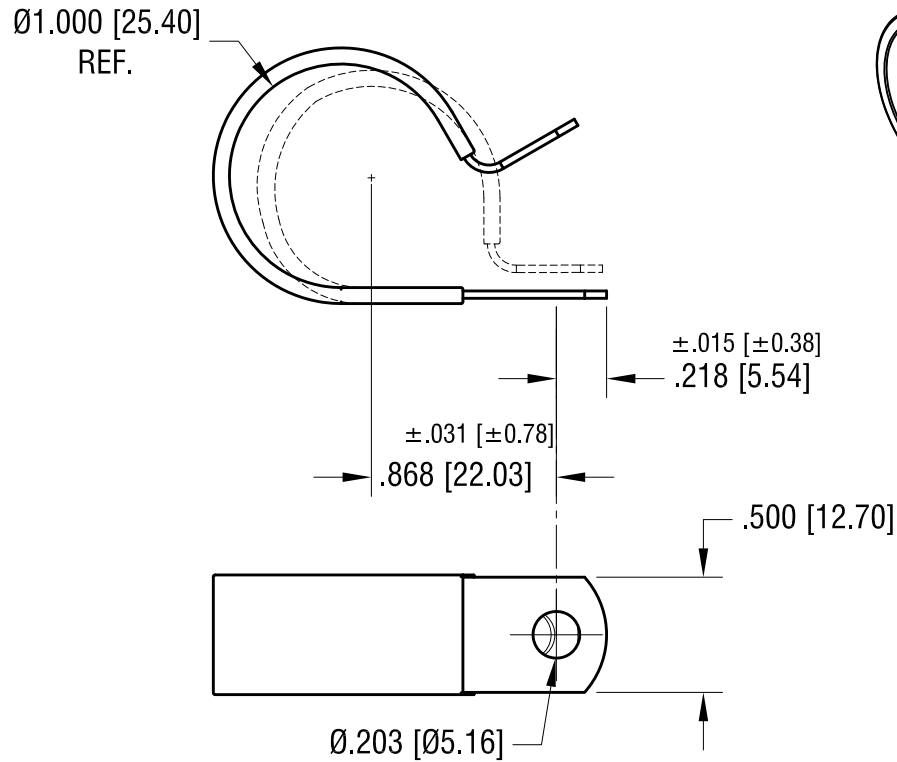

2.27.24	CHANGE AS PER PCN 24-015	B
10.18.06	CHANGE AS PER ECN 06-070	A
DATE	DESCRIPTION	REV.

KEYSTONE ELECTRONICS CORP.			
www.keyelco.com • NEW HYDE PARK, NY 11040 • Tel (516) 328-7500			
PART NAME INSULATED STEEL CABLE CLAMP			
MATERIAL .032 [0.81] TH'K STEEL, BLACK VINYL			
FINISH ZINC PLATE CLEAR CHROMATE		DRN BY BOONE	DATE 10.20.99
		APP'D RH	SCALE 1.5X
TOLERANCES DECIMAL ANGULAR ± 1° UNLESS OTHERWISE SPECIFIED	INCH [MM] ± .010 [± .025]	CODE C	DWG NO. 8134