

Jun.1.2024 Copyright 2024 HIROSE ELECTRIC CO., LTD. All Rights Reserved.
 In case of consideration for using Automotive equipment / device which demand high reliability, kindly contact our sales window correspondents.

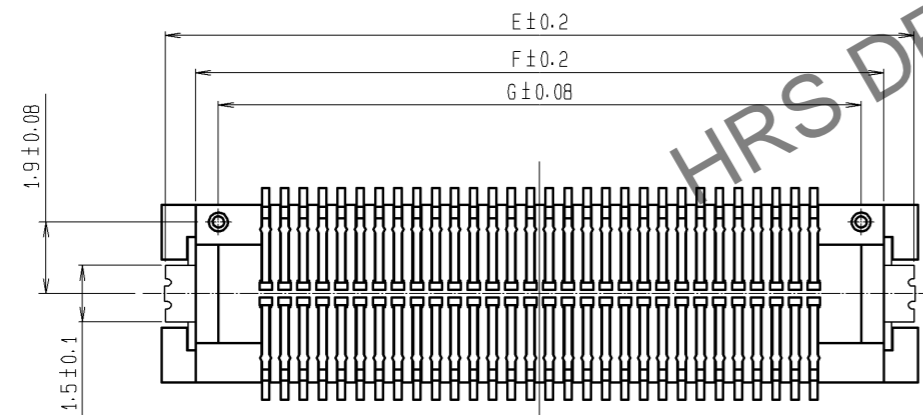
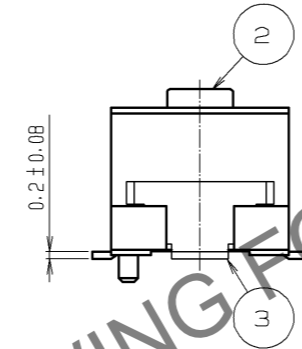
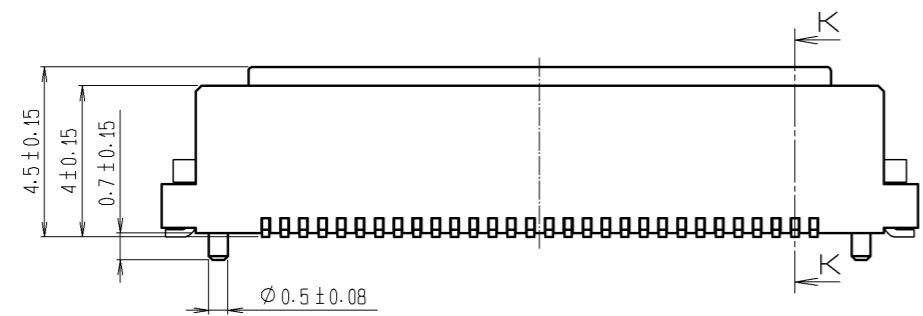
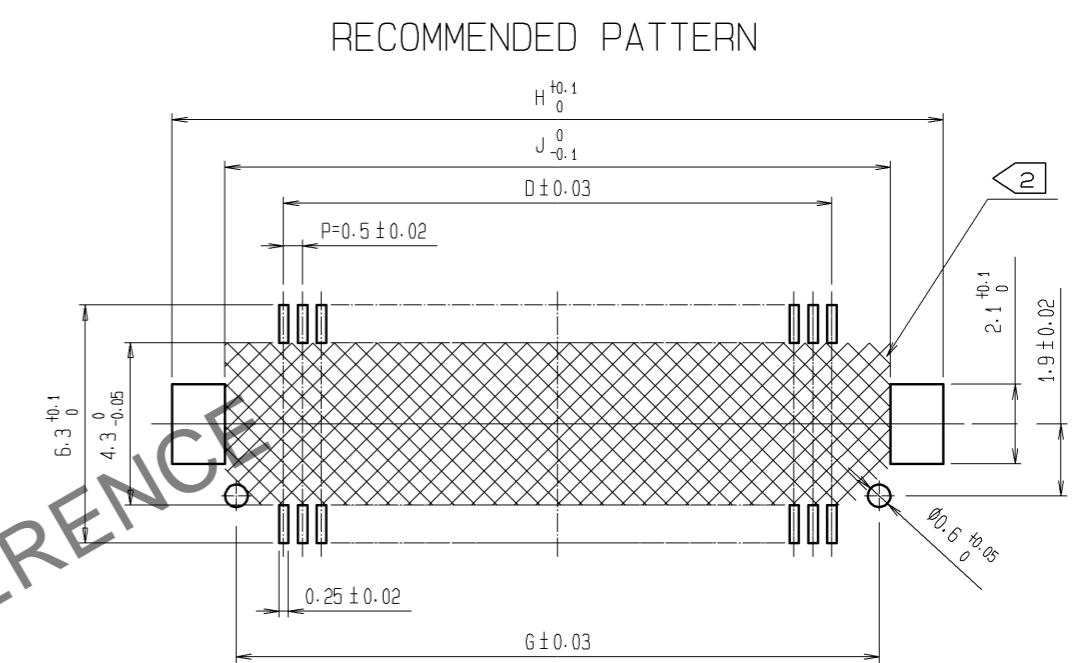
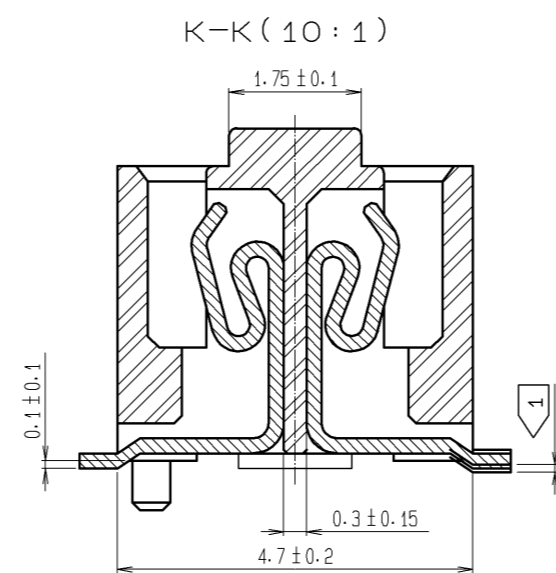
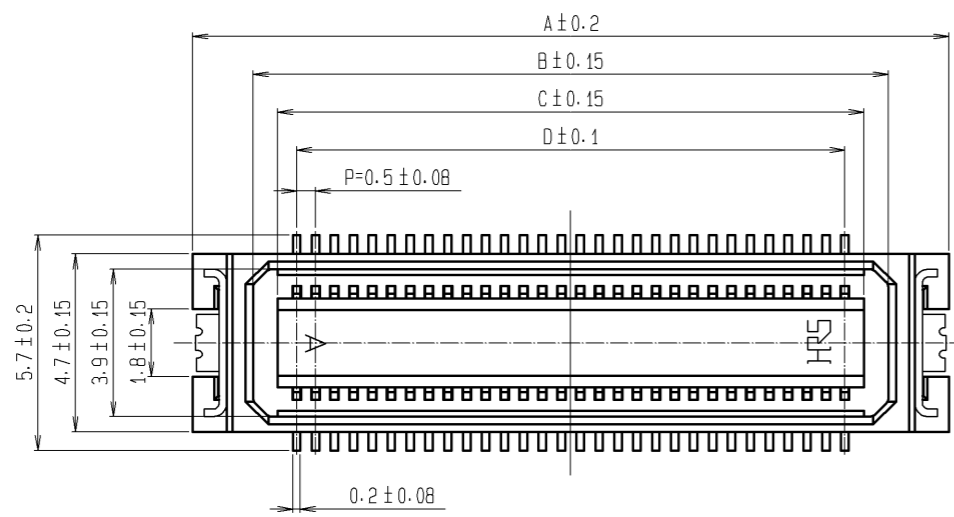

CODE NO.	CONTACT	A	B	C	D	E	F	G	H	J
CL683-0042-7-57	20	10	6.8	5.5	4.5	9.8	8.2	7	10.4	7.6
CL683-0043-0-57	30	12.5	9.3	8	7	12.3	10.7	9.5	12.9	10.1
CL683-0044-2-57	40	15	11.8	10.5	9.5	14.8	13.2	12	15.4	12.6
CL683-0045-5-57	50	17.5	14.3	13	12	17.3	15.7	14.5	17.9	15.1
CL683-0046-8-57	60	20	16.8	15.5	14.5	19.8	18.2	17	20.4	17.6
CL683-0047-0-57	70	22.5	19.3	18	17	22.3	20.7	19.5	22.9	20.1
CL683-0048-3-57	80	25	21.8	20.5	19.5	24.8	23.2	22	25.4	22.6

NOTES ① LEAD CO-PLANARITY INCLUDE REINFORCED METAL FITTINGS SHALL BE 0.1mm MAX.
 ② WATCH NOT LET THE CONTACTS TOUCH THE SECTION ESPECIALLY WHEN THE PADS OF AREA NOT RESIST FINISHED.

MATED HEIGHT(h)		(mm)
HEADER NO.	RECEPTACLE NO.	
	DF17#(4.0)-*DS-0.5V(57)	
DF17#(2.0)-*DP-0.5V(57)		6
DF17#(4.0)-*DP-0.5V(57)		8

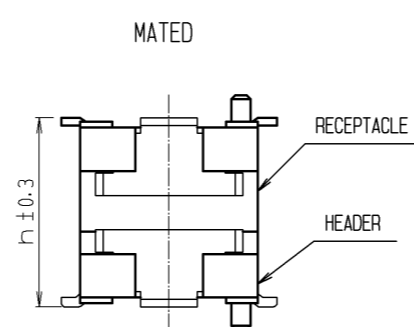

NO.	MATERIAL	FINISH . REMARKS	NO.	MATERIAL	FINISH . REMARKS
2	POLYAMIDE (PA6T)	WHITE BEIGE , UL94V-0	6	PS	BLACK(PLASTIC REEL)
1	PHOSPHER BRONZE	CONTACT AREA : GOLD PLATED 0.1µm min LEAD AREA : TIN PLATED 1µm min UNDER PLATING : NICKEL PLATED 1µm min	5	POLYESTER	CLEAR (COVER TAPE)
			4	PS	CLEAR (EMBOSSD CARRIER TAPE)
			3	PHOSPHER BRONZE	TIN PLATED : 1µm min UNDER PLATING : NICKEL PLATED 1µm min

UNITS	SCALE	COUNT	DESCRIPTION OF REVISIONS	DESIGNED	CHECKED	DATE
mm	5 : 1	△				

APPROVED : KH. IKEDA	11.11.30	DRAWING NO.	EDC3-162131-77
CHECKED : TS. MIYAZAKI	11.11.30	PART NO.	DF17(4.0)-*DS-0.5V(57)
DESIGNED : YH. MICHIDA	11.11.30	CODE NO.	CL683
DRAWN : YH. MICHIDA	11.11.30		

Jun.1.2024 Copyright 2024 HIROSE ELECTRIC CO., LTD. All Rights Reserved.
In case of consideration for using Automotive equipment / device which demand high reliability, kindly contact our sales window correspondents.

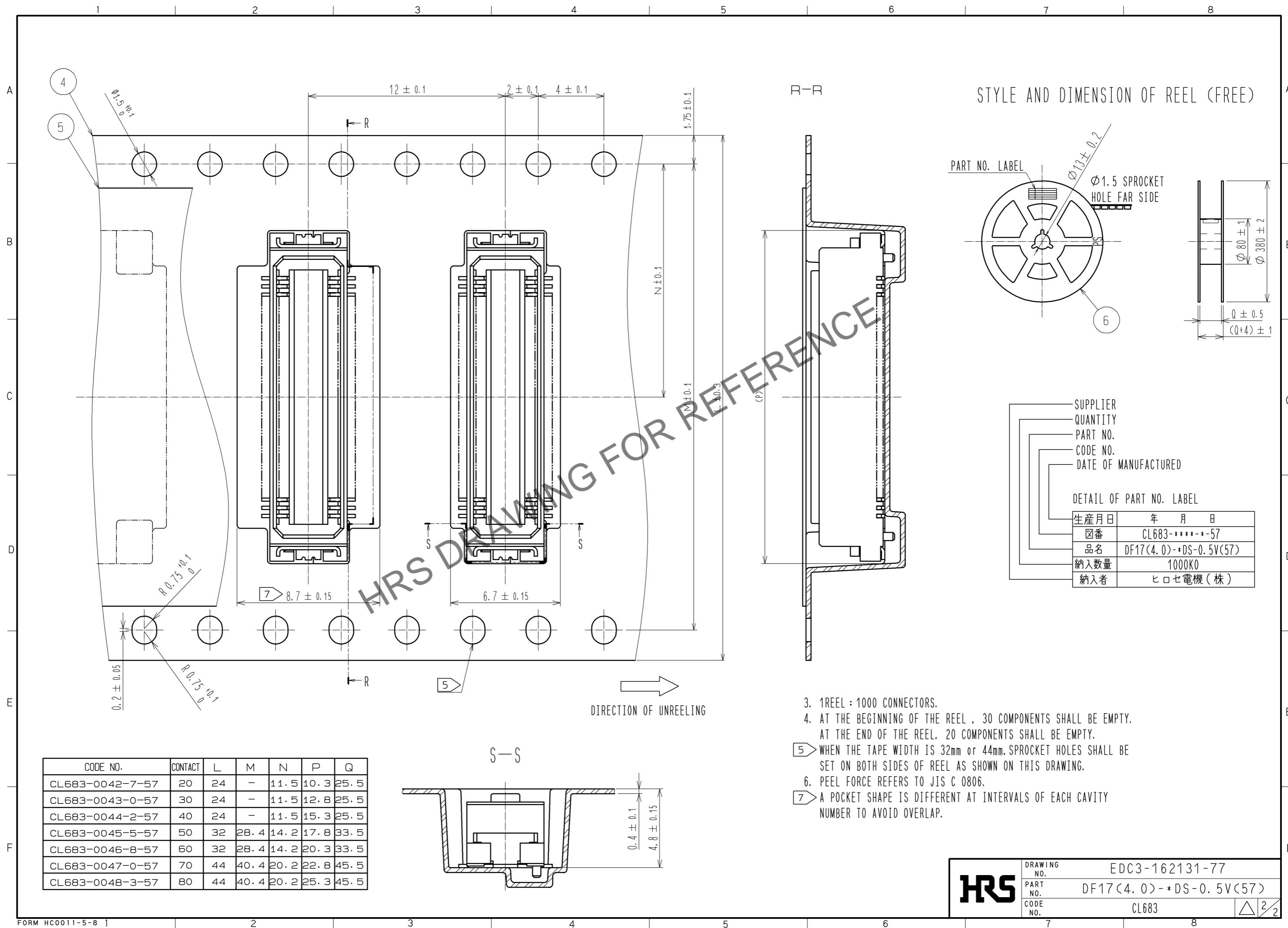

CODE NO.	CONTACT	L	M	N	P	Q
CL683-0042-7-57	20	24	-	11.5	10.3	25.5
CL683-0043-0-57	30	24	-	11.5	12.8	25.5
CL683-0044-2-57	40	24	-	11.5	15.3	25.5
CL683-0045-5-57	50	32	28.4	14.2	17.8	33.5
CL683-0046-8-57	60	32	28.4	14.2	20.3	33.5
CL683-0047-0-57	70	44	40.4	20.2	22.8	45.5
CL683-0048-3-57	80	44	40.4	20.2	25.3	45.5

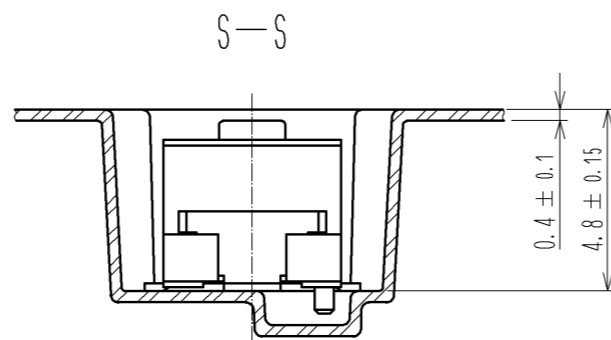

3. 1 REEL : 1000 CONNECTORS.
4. AT THE BEGINNING OF THE REEL , 30 COMPONENTS SHALL BE EMPTY.
AT THE END OF THE REEL, 20 COMPONENTS SHALL BE EMPTY.
5. WHEN THE TAPE WIDTH IS 32mm or 44mm, SPROCKET HOLES SHALL BE SET ON BOTH SIDES OF REEL AS SHOWN ON THIS DRAWING.
6. PEEL FORCE REFERS TO JIS C 0806.
7. A POCKET SHAPE IS DIFFERENT AT INTERVALS OF EACH CAVITY NUMBER TO AVOID OVERLAP.

HRS	DRAWING NO.	EDC3-162131-77
	PART NO.	DF17(4.0)-*DS-0.5V(57)
	CODE NO.	CL683
		\triangle 2/2