

RK09K RK09D

9mm Size Insulated Shaft Snap-in Type

Compact type potentiometer with 9.8mm width is ideal for designing high density sets

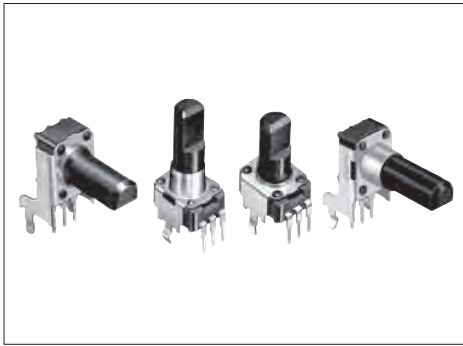

Typical Specifications

Items	Specifications
Total resistance tolerance	±20%
Maximum operating voltage	50V AC, 20V DC
Total rotational angle	RK09K: 280° ±5° RK09D: 300° ±5°
Rotational torque	1 to 8mN·m
Operating life	5,000 cycles
Operating temperature range	-10°C to +70°C

Product Line

Number of resistor elements	Control part orientation (Installed height)	Total rotational angle	Collar (Sleeve type)	Shaft type	Length of the shaft LM ₁ (mm)	Center detent	Total resistance(k.Ω)	Resistance taper	Minimum order unit (pcs.)		Products No.	Drawing No.						
									Japan	Export								
Single-unit (20V DC)	Vertical	280°	Without	Flat	15	With	10	1B	1,000	2,000	RK09K113004U	2						
						Without					RK09K1130A6S							
						With					RK09K11300DR							
						Without					RK09K1130A8G							
				Knob	20	With					RK09K1130081							
						Without					RK09K1130A5R							
						Screw driver					15	Without	RK09K1130AP5					
											20	Without	RK09K1130AST					
	Horizontal H=6.5mm	280°	Without	Flat	15	With	10	1B	1,000	2,000	RK09K111009J	1						
						Without					RK09K1110AK4							
						With					RK09K11100DN							
						Without					RK09K1110AAR							
				Knob	20	With					RK09K1110077							
						Without					RK09K1110A0J							
						Flat					15	Without	RK09K1110AMJ					
												Without	RK09K1110B26					
	Horizontal H=10mm	280°	Without	Flat	20	With	10	1B	1,000	2,000	RK09D1130C3W	4						
						Without					RK09D1130C1B							
						With					RK09D1130C3C							
						Without					RK09D1130C2P							
Vertical				300°	With	Flat					25	With	10	1B	1,000	2,000	RK09D1110C1A	3
												Without					RK09D1110C1A	
												With					RK09D1110C1A	
												Without					RK09D1110C1A	
Horizontal H=10mm	300°	With	Flat	25	With	10	1B	1,000	2,000	RK09D1110C1A	3							
					Without					RK09D1110C1A								

Clear Shaft

Number of resistor elements	Control part orientation (Installed height)	Total rotation angle	Collar (Sleeve type)	Shaft type	Length of the shaft LM ₁ (mm)	Center detent	Total resistance(k.Ω)	Resistance taper	Minimum order unit (pcs.)		Products No.	Drawing No.
									Japan	Export		
Single-unit (20V DC)	Vertical	280°	Without	Knob	20	Without	10	1B	1,000	2,000	RK09K1130D62	7

Note

Other varieties are also available. Refer to "Other Specifications" (P.316).

Packing Specifications





Bulk

Number of packages (pcs.)		Export package measurements (mm)
1 case / Japan	1 case / export packing	
1,000	2,000	528×369×178

Refer to P.316 for other specifications.
Refer to P.317 for ordering products not listed.
Refer to P.331 for soldering conditions.

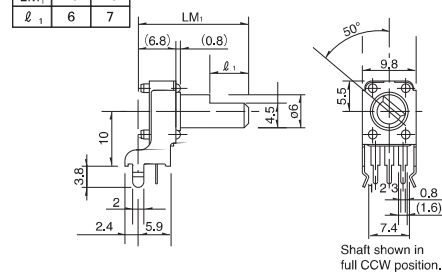
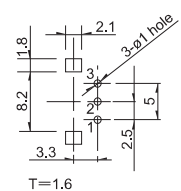
■ Dimensions

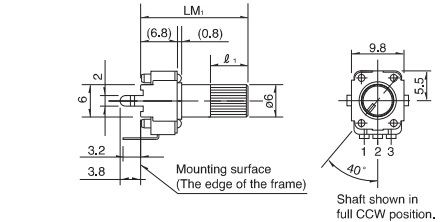
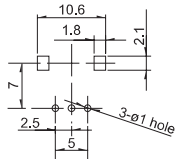
Unit:mm

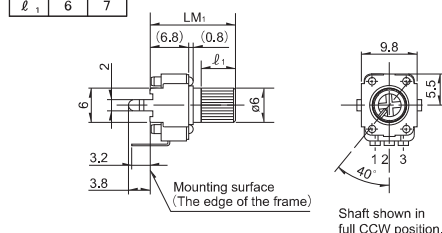
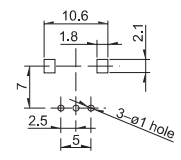
No.	Photo	Style	PC board mounting hole dimensions (Viewed from mounting side)						
6	<p>Horizontal RK09K111</p> 	<table border="1"> <tr> <td>LM₁</td> <td>15</td> <td>20</td> </tr> <tr> <td>ℓ₁</td> <td>6</td> <td>7</td> </tr> </table>  <p>Shaft shown in full CCW position.</p>	LM ₁	15	20	ℓ ₁	6	7	
LM ₁	15	20							
ℓ ₁	6	7							
7	<p>Vertical RK09K113</p>  <p>Clear Shaft</p>	<table border="1"> <tr> <td>LM₁</td> <td>15</td> <td>20</td> </tr> <tr> <td>ℓ₁</td> <td>6</td> <td>7</td> </tr> </table>  <p>Shaft shown in full CCW position.</p>	LM ₁	15	20	ℓ ₁	6	7	
LM ₁	15	20							
ℓ ₁	6	7							
8	<p>Vertical RK09K113</p> 	<table border="1"> <tr> <td>LM₁</td> <td>15</td> <td>20</td> </tr> <tr> <td>ℓ₁</td> <td>6</td> <td>7</td> </tr> </table>  <p>Shaft shown in full CCW position.</p>	LM ₁	15	20	ℓ ₁	6	7	
LM ₁	15	20							
ℓ ₁	6	7							

■ Terminal Layout / Circuit Diagram

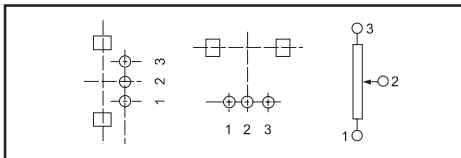

- Rotary Potentiometers
- Slide Potentiometers
- Metal Shaft
- Insulated Shaft
- Knob Operating
- Through Shaft Type
- Ring Type

9mm Size Insulated Shaft Snap-in Type / Other Specifications

In addition to the Product Line, we accommodate the following specifications. Combinations not included in the Product Line are treated as semi-standard products.

Total Resistance Variety



Total resistance (k Ω)	5	10	20	50	100	200
------------------------	---	----	----	----	-----	-----

Resistance Taper

Resistance taper	15A	1B	3B	15C
------------------	-----	----	----	-----

Shaft Variety

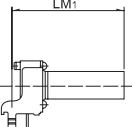
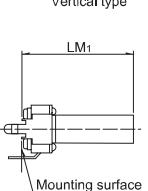
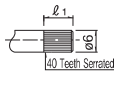
Unit:mm

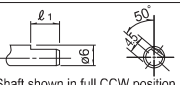
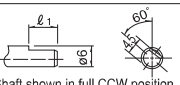
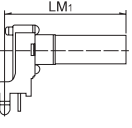
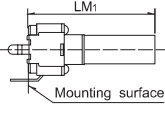
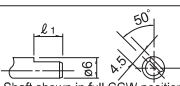
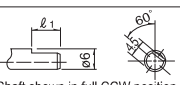
Style	Shaft type		Shaft color										
	Knob variety	Detail dimensions											
<div style="display: flex; justify-content: space-around;"> <div style="text-align: center;"> <p>Horizontal type</p>  </div> <div style="text-align: center;"> <p>Vertical type</p>  </div> </div>	<p>Knob type (φ6)</p>  <p>Shaft shown at center position</p>	<table border="1"> <tr> <td>LM₁</td> <td>15</td> <td>20</td> <td>25</td> <td>30</td> </tr> <tr> <td>l₁</td> <td>6</td> <td>7</td> <td>7</td> <td>7</td> </tr> </table>	LM ₁	15	20	25	30	l ₁	6	7	7	7	Black
	LM ₁	15	20	25	30								
	l ₁	6	7	7	7								
	<p>Screw-driver adjustment type</p>  <p>Shaft shown at center position</p>	<table border="1"> <tr> <td>LM₁</td> <td>9.5</td> <td>15</td> <td>20</td> <td></td> </tr> <tr> <td>l₁</td> <td>—</td> <td>6</td> <td>7</td> <td></td> </tr> </table>	LM ₁	9.5	15	20		l ₁	—	6	7		
	LM ₁	9.5	15	20									
	l ₁	—	6	7									
<p>Flat type</p>  <p>Shaft shown in full CCW position</p>	<table border="1"> <tr> <td>LM₁</td> <td>15</td> <td>20</td> <td>25</td> <td>30</td> </tr> <tr> <td>l₁</td> <td>6</td> <td>7</td> <td>12</td> <td>12</td> </tr> </table>	LM ₁	15	20	25	30	l ₁	6	7	12	12	Gray (15, 20, 25) Black (30)	
LM ₁	15	20	25	30									
l ₁	6	7	12	12									
<p>Flat type</p>  <p>Shaft shown in full CCW position</p>	<table border="1"> <tr> <td>LM₁</td> <td>15</td> <td>20</td> <td>25</td> <td>30</td> </tr> <tr> <td>l₁</td> <td>6</td> <td>7</td> <td>12</td> <td>12</td> </tr> </table>	LM ₁	15	20	25	30	l ₁	6	7	12	12		
LM ₁	15	20	25	30									
l ₁	6	7	12	12									
<div style="display: flex; justify-content: space-around;"> <div style="text-align: center;"> <p>With collar</p>  </div> <div style="text-align: center;"> <p>Mounting surface</p>  </div> </div>	<p>Flat type</p>  <p>Shaft shown in full CCW position</p>	<table border="1"> <tr> <td>LM₁</td> <td>20</td> <td>25</td> <td>30</td> </tr> <tr> <td>l₁</td> <td>7</td> <td>12</td> <td>12</td> </tr> </table>	LM ₁	20	25	30	l ₁	7	12	12	Black		
	LM ₁	20	25	30									
l ₁	7	12	12										
	<p>Flat type</p>  <p>Shaft shown in full CCW position</p>	<table border="1"> <tr> <td>LM₁</td> <td>20</td> <td>25</td> <td>30</td> </tr> <tr> <td>l₁</td> <td>7</td> <td>12</td> <td>12</td> </tr> </table>	LM ₁	20	25	30	l ₁	7	12	12	Gray (20, 25) Black (30)		
LM ₁	20	25	30										
l ₁	7	12	12										

Note

Marked are specifications recommended by Alps Alpine.

9mm Size Insulated Shaft Snap-in Type / Ordering Products Not Listed

In addition to the Product Line, we accommodate the following specifications. Combinations not included in the Product Line are treated as semi-standard products. Please refer to the notation example below.

Sample Part Number

R K 0 9 K 1 1 3 0 — **F 2 0** — **C 0** — **B 1 0 3**

Model type

Code	Model type	
K111	280° single-unit	Horizontal H=6.5
K113	280° single-unit	Vertical
D111	300° single-unit	Horizontal H=10
D113	300° single-unit	Vertical

*For other horizontal type mount height requirements, please indicate separately.

Shaft type

Code	Shaft type	Code	Shaft type
F	Flat	X	Screw driver
K	Knob	—	—

*All RK09D types are only available in flat format.

Length of the shaft LM₁ (mm)

Code	Length of the shaft	Code	Length of the shaft
15	15	25	25
20	20	30	30

*20, 25 and 30 are the only available RK09D types.
*9.5, 15 and 20 are the only available models in the Screwdriver shape.

Detent

Code	Center detent
C0	Without
C1	With

Resistance taper

Code	Resistance taper	Code	Resistance taper
A	15A	C	15C
B	1B	V	3B

B: For tone & general
V: For vol.

Total resistance

Code	Total resistance (k Ω)	Code	Total resistance (k Ω)
502	5	503	50
103	10	104	100
203	20	204	200

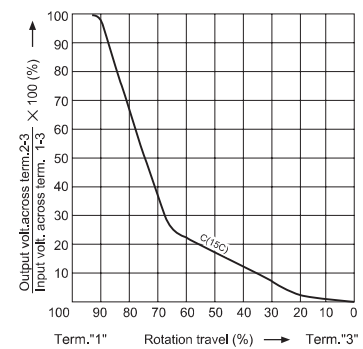
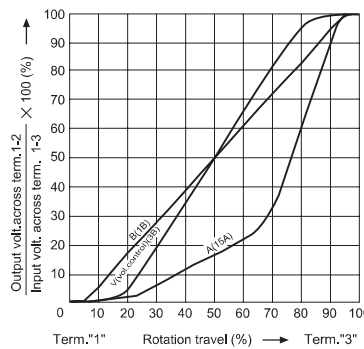

Notes

1. RK09D comes with a collar.
2. The recommended specification for RK09K does not include a collar. For collar requirements please indicate separately.
3. Marked are specifications recommended by Alps Alpine.

Rotary Potentiometers

Slide Potentiometers

Metal Shaft

Insulated Shaft











Knob Operating

Through Shaft Type

Ring Type

Insulated Shaft Potentiometers

List of Varieties

Type	9mm size		11mm size	12mm size	14mm size	
Series	RK09K11 RK09D11	RK09Y11L	RK11K	RK12L12	RK14K	
	Single-unit	Single-unit	Single-unit	Dual-unit	Dual-unit	
Photo						
Control part orientation	Vertical / Horizontal	Horizontal	Vertical / Horizontal			
Bushing	Without		With	Without	With	
Operating temperature range	-10°C to +70°C					
Operating life	5,000 cycles	1,000,000 cycles	15,000 cycles			
Available for automotive use	—	—	—	—	—	
Life cycle						
Electrical performance	Total resistance (k Ω)	5, 10, 20, 50, 100, 200	10	5, 10, 20, 50, 100, 200		
	Resistance taper	15A, 1B, 3B, 15C	B	15A, 1B, 3B, 15C		
	Total resistance tolerance	±20%	±30%	±20%		
	Rated power	0.05W	0.01W	0.05W		
	Maximum operating voltage	50V AC 20V DC	50V AC 5V DC	50V AC 20V DC	50V AC for AC only	
	Gang error	—	—	—	For volume control -40dB to 0dB 3dB max. For tone control within 2dB max. at center	
	Insulation resistance	100MΩ min. 250V DC		100MΩ min. 500V DC	100MΩ min. 250V DC	
	Voltage proof	250V AC for 1minute		500V AC for 1minute	300V AC for 1minute	
	Center-taps	Without		Without / With	Without	Without / With (Volume control)
Mechanical performance	Detent	Without, Center	Without	Without, Center	Without	Without, Center
	Stopper strength	0.3N·m	—	Without bushing 0.5N·m With bushing 0.6N·m	0.5N·m	0.6N·m
	Push-pull strength	50N max.	30N max.	80N max.		
	Vibration	10 to 55 to 10Hz/min, the amplitude is 1.5mm for all the frequencies, in the 3 direction of X, Y and Z and for 2 hours respectively				
Shaft configuration	Flat type, Knob type, Screwdriver type	Flat type				
Terminal style	Insertion					
Page	313 329 (for Mixers)	318	319 329 (for Mixers)	322 329 (for Mixers)	325 329 (for Mixers)	

Insulated Shaft Potentiometers Soldering Conditions	331
Potentiometers Cautions	384
Potentiometers Measurement and Test Methods	386
Potentiometers Resistance Taper	388

Note

● Indicates applicability to all products in the series.

Insulated Shaft Potentiometers / Soldering Conditions

■ Reference for Manual Soldering

Series	Tip temperature	Soldering time	No. of solders
RK09D, RK09K, RK09Y11L, RK11K, RK12L, RK14K	350°C max.	3s max.	1 time

■ Reference for Dip Soldering

Series	Preheating		Dip soldering		No. of solders
	Soldering surface temperature	Heating time	Soldering temperature	Soldering time	
RK12L	100°C	1 min. max.	260°C max.	5s max.	2 time max.

Rotary Potentiometers

Slide Potentiometers

Metal Shaft

Insulated Shaft

Knob Operating

Through Shaft Type

Ring Type