



Tangshan Guoxin Jingyuan Electronics Co.,Ltd

Add: Xinxing Electronics Industrial Park, Yutian,Tangshan,Hebei,China

TEL: 86-315-6118243

E-mail: sales@jingyuan.com

FAX: 86-315-6113576

Web : www.jingyuan.com

APPROVAL SHEET

Customer : _____

Part Number : _____

JYEG P/N : JYD3

Holder : SMD3225

Frequency : 8.000~62.400MHZ

Manufacturer : Guoxin Jingyuan Electronics

Date : 2025/12/20

Prepared	Checked	Approved
Huang Mingxing	Yang Tiesheng	Zhang Liqiang

(For Customer Use)

Acceptable	Non-Acceptable

1.This specification applies to SMD quartz crystal unit with a frequency of 8.000~62.400MHz.

2. Electrical characteristics

ITEM/TYPE	SMD3225
Frequency Range	8.000~62.400MHz
Mode of Vibration	Fundamental
Frequency Tolerance (at 25°C)	±10ppm,or specify
Frequency Stability Over Operating Temperature Range	±30ppm/-40~85°C, ±50ppm, ±100ppm/-40~125°C, or specify
Shunt Capacitance	2pF Max.
Load Capacitance	6~50pF or Series
Resonance Resistance	As per below table1.
Drive Level	300μW Max.
Aging	±2ppm/year
Insulation Resistance	500MΩ@DC100V
Storage Temperature Range	-55~125°C

3. Table 1. Equivalent Series Resistance(ESR)

Frequency	Resonance Resistance
8.000~12.000MHz	500Ω Max.
12.000~20.000MHz	70Ω Max.
20.000~40.000MHz	40Ω Max.
40.000~62.400MHz	25Ω Max.

3. Construction

3.1 Crystal enclosure seal:

- Seam seal
- resistance weld
- cold weld

3.2 crystal enclosure medium

- nitrogen
- vacuum
- dry air

4.Dimension:

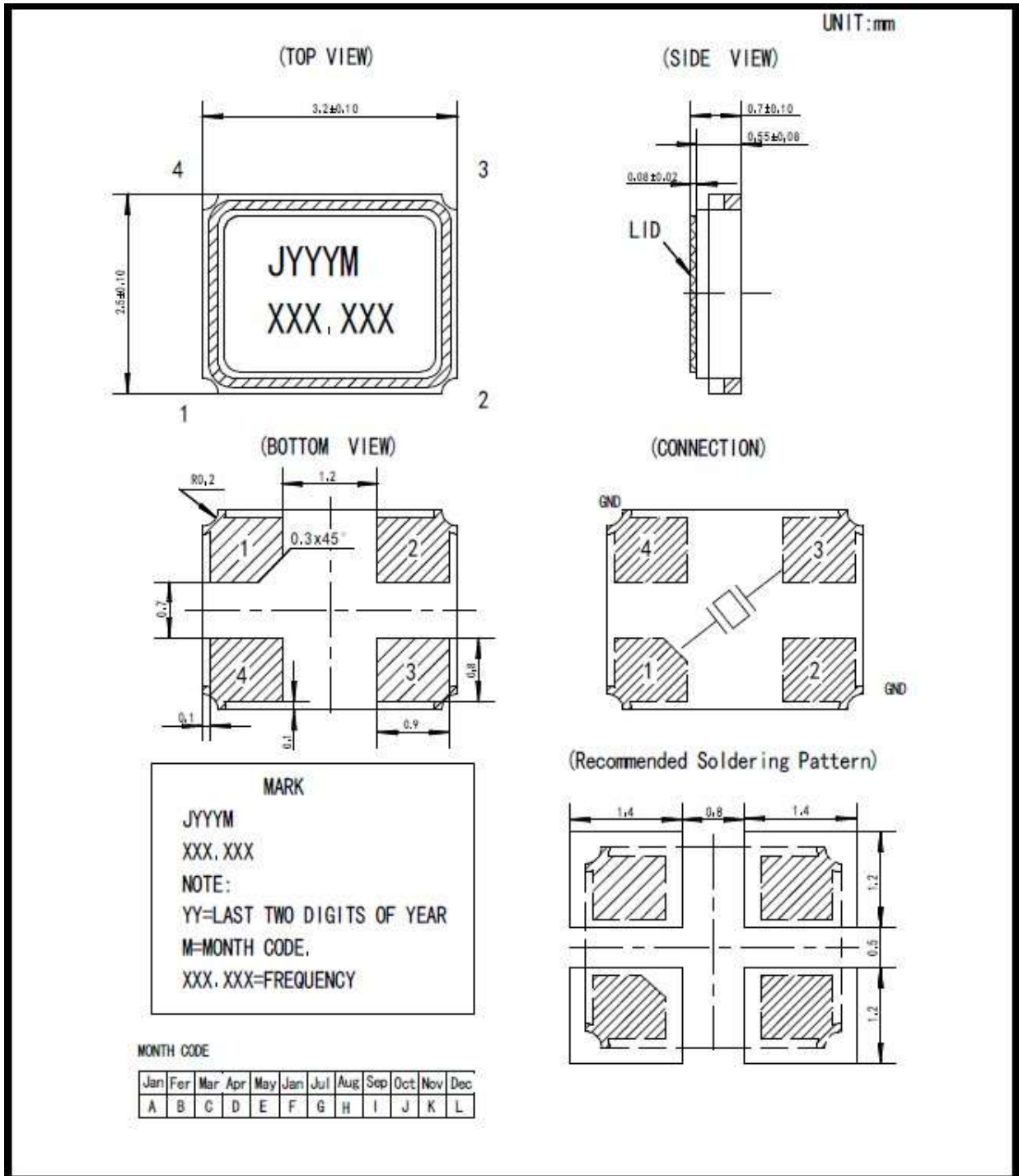

5. Marking

- Laser Marking
- Ink Marking

6.Inside Structure

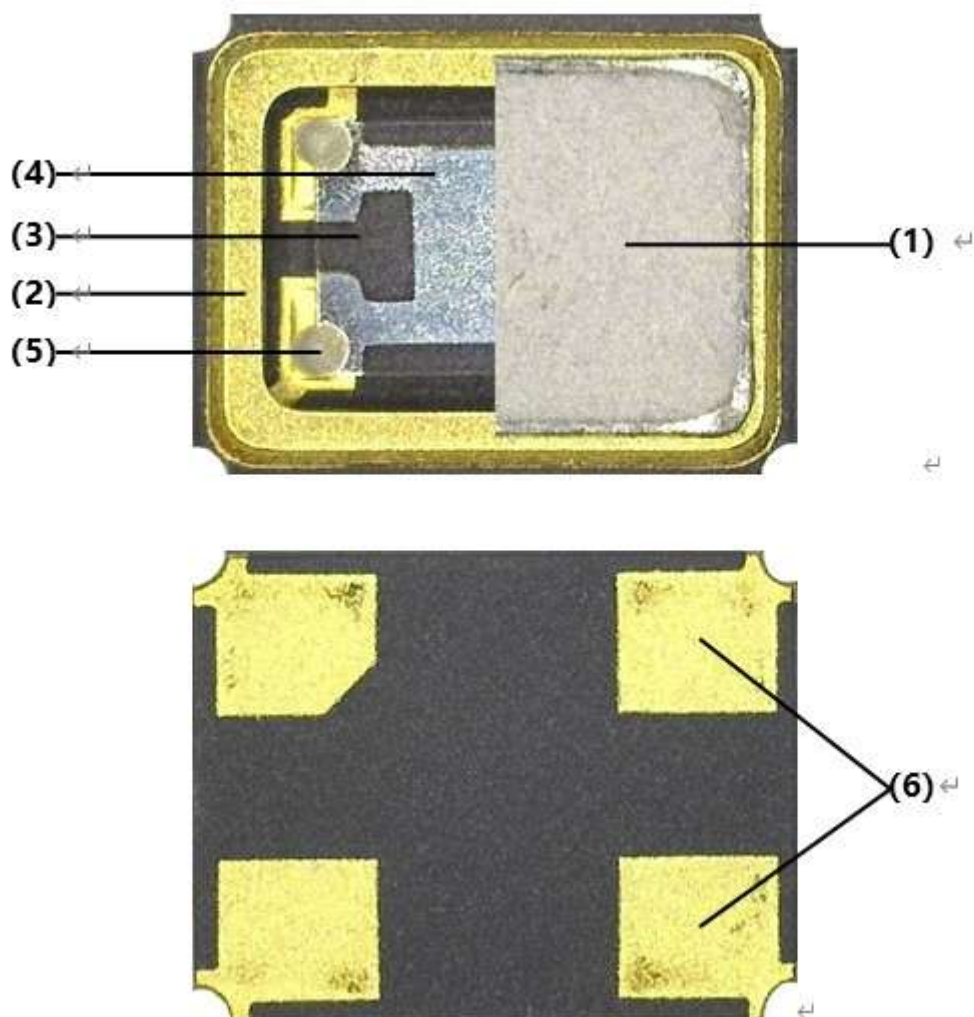

No.	Name	Material
(1)	Can	Fe-Co-Ni
(2)	Base	Ceramic
(3)	Blank	Quartz
(4)	Electrode	Ag
(5)	Epoxy	Silicon based
(6)	Soldering Pads	Au plated

7.Taping Dimension and Packing Instruction

7.1

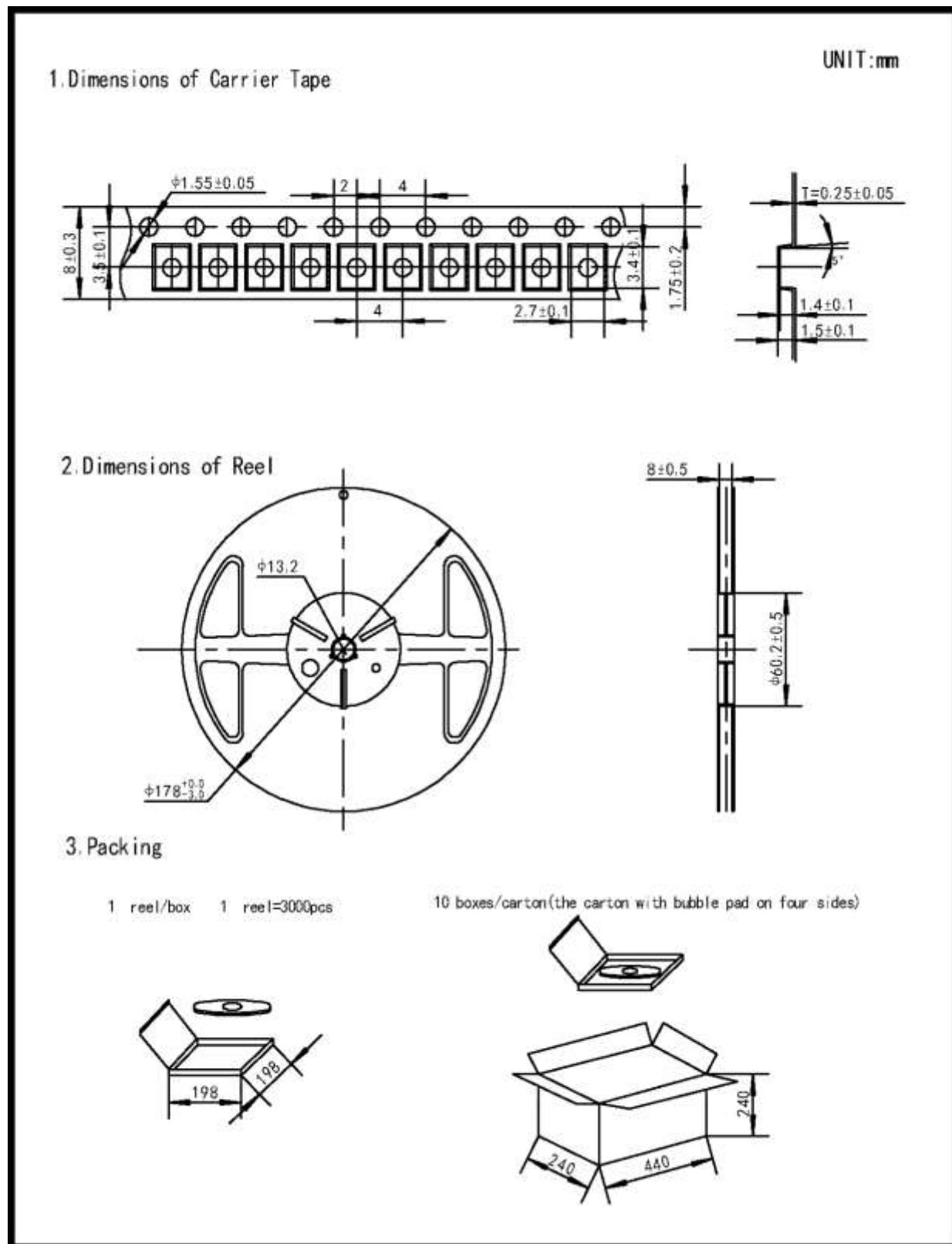

7.2

Release strength of cover tape

It has to be between 30g to 90g under following condition.

Pulling direction : 165 deg. to 180 deg.

Speed : 300mm/min.

Otherwise unless specified.

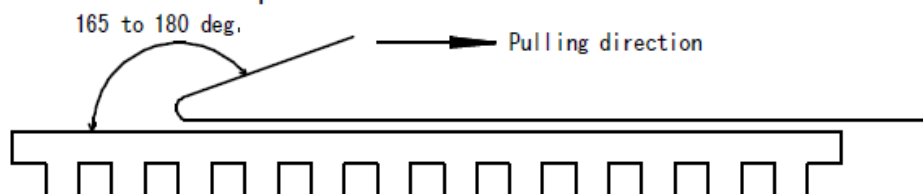

8. Reliability characteristic:

NO	Item	Condition	Specifications	Reference
8.1	High Temperature Exposure (Storage) 高温存储	1000 hrs. at rated operating temperature and powered. Measurement at 24±2 hours after test conclusion. 元件就贮存在 85°C 下 1000 小时，在试验结束后 24±2 小时测试。	$\Delta F/F_0 \leq \pm 10\text{ppm}$ ESR ≤ 5Ω or 20%	MIL-STD-202 Method 108
8.2	Temperature Cycling 温度循环	-40° C to 125°C part the 1000 cycles will be at that perature rating. Measurement at 24 ± 2 hours after test conclusion. 30min maximum dwell time at each temperature extreme. 1 min. maximum transition time. 从 -40°C ~ +125°C 1000 次循环。在试验结束后 24 ± 2 小时测试。每个温度的停留时间不超过 30 分钟。转换时间不超过 1 分钟。	$\Delta F/F_0 \leq \pm 10\text{ppm}$ ESR ≤ 5Ω or 20%	JESD22 Method JA-104
8.3	Biased Humidity 稳态湿热	1000 hours 85°C/85%RH. Rated VDD applied with 1MΩ and inverter in parallel, 2X resonator CL capacitors between each resonator leg and GND. Measurement at 24±2 hours after test conclusion. 在温度 85°C，湿度 85% 的条件下放置 1000 个小时在试验结束后 24±2 小时测试。	$\Delta F/F_0 \leq \pm 10\text{ppm}$ ESR ≤ 5Ω or 20%	MIL-STD-202 Method 103
8.4	Operational Life 高温寿命	125°C 1000 hrs. Measurement at 24±2 hours after test conclusion. 125°C 下 1000 个小时，用相同测试线路在时间结束后 24±2 小时测试。	$\Delta F/F_0 \leq \pm 10\text{ppm}$ ESR ≤ 5Ω or 20%	MIL-STD-202 Method 108

8.5	Mechanical Shock 机械冲击	MIL-STD-202Method 213Figure 1 of Method 213. Condition C 见 213 方法, 试验条件: 半正弦波 峰值 100g 持续时间 6ms 速度变化 3.75m/s, 对样品 6 个方向 3 次, 共 18 次施以冲击	$\Delta F/F_0 \leq \pm 10\text{ppm}$ ESR $\leq 5\Omega$ or 20%	MIL-STD-202 Method 213
8.6	Vibration 振动	MIL-STD-202Method 204 5g 的力 20 分钟, 用 8*5*0.031 英寸的 PCB 在 3 个方向各做 12 个循环。在 8 英寸边上有 7 个支撑点, 在对面角上两个支撑点。器件安装在任意一个支撑点的 2 英寸范围内。测试从 10HZ-2000HZ.	$\Delta F/F_0 \leq \pm 10\text{ppm}$ ESR $\leq 5\Omega$ or 20%	MIL-STD-202 Method 204
8.7	Resistance to Soldering Heat 耐焊接热	Condition B No pre-heat of samples. Note: SingleWave solder - Procedure 1 with solder within 1.5 mm of device body for Leaded. Procedure 1 except 245°C and immerse only to level to cover terminals for SMD. 未预热的样品 Condition B. 备注: 单波焊接 -Porcedure 1 引脚产品焊料少于 1.5mm,除了 245°C外其他 Procedure 1, SMD 产品浸到覆盖 SMD 引脚。	$\Delta F/F_0 \leq \pm 10\text{ppm}$ ESR $\leq 5\Omega$ or 20%	MIL-STD-202 Method 210
8.8	Solderability 可焊性	引脚产品: Method A@245°C, category 3. SMD 产品: Method D category3 @260 °C ✓	Electrical Test not required. Magnification 50 X.>95%tin 不测电参数 >95%浸润.	J-STD-002
8.9	Board Flex 线路板弯曲	60 sec minimum holding time. 最少保留 60 秒。	10 倍放大镜下检查没有明显伤痕。	AEC Q200-005
8.10	Terminal Strength 引线、引脚强度 (SMD)	Terminal Strength Surface Mount / Shear Stress Test 施加 1.8kg 力 60 sec 测试带引脚器件的引脚整体试验。 条件: A(2.27Kg) C(227g)	有明显断裂、伤痕。	AEC Q200-006

9.All products are RoHs compliant

10. Reflow Profile

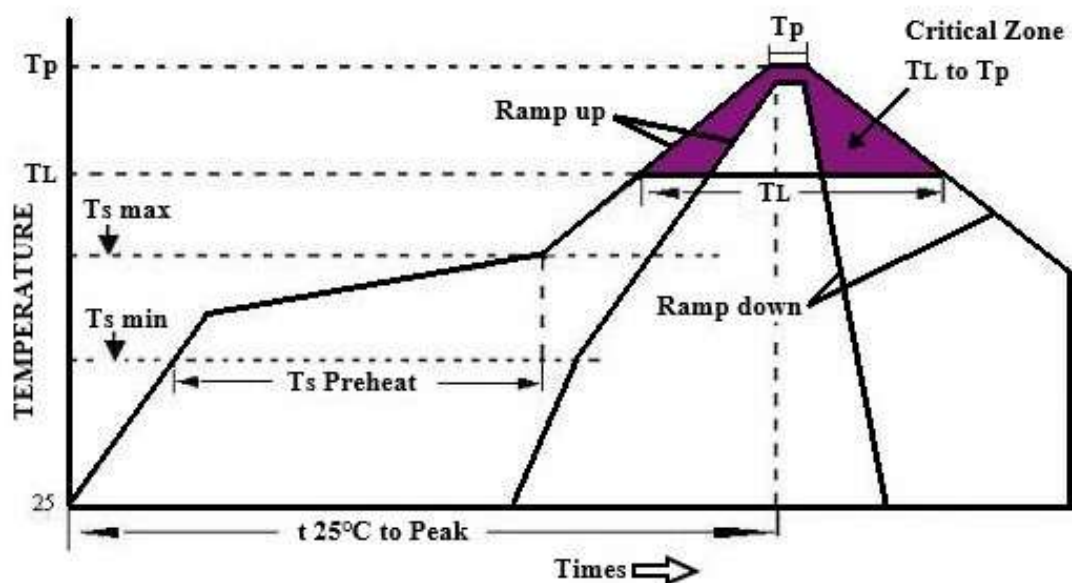

High Temperature Infrared /Convection

Note: Temperature shown are applied to body of device

Ts max to TL(Ramp-up Rate)	3°C/second max
Preheat	
Temperature Min(Ts Min)	150°C
Temperature Typical(Ts Typ)	175°C
Temperature Max.(Ts Max)	200°C
Time(ts)	60-180 seconds
Ram-up Rate(TL to Tp)	3°C/second Max
Time Maintained Above:	
--Temperature(TL)	217°C
--Time(TL)	60-150seconds
Peak Temperature (Tp)	260°C Max for 10 seconds
Time within 5°C of actual peak(tp)	20-40 seconds
Ramp-down Rate	6°C/seconds Max
Tune 25°C to Peak Temperature(t)	8 minutes Max
Moisture Sensitivity Level	Level 1

High Temperature Manual Soldering

Note: Temperature shown are applied to body of device

260°C Max for 10 seconds Max, 2 times Max