

2-520183-4 ✓ ACTIVE

Ultra-Fast | Ultra-Fast 250

TE Internal #: 2-520183-4

Quick Disconnects, Receptacle, 22 – 18 AWG Wire Size, .32 – .82 mm² Wire Size, Mating Tab Width 6.35 mm [.25 in], Straight, Ultra-Fast 250

[View on TE.com >](#)



Terminals & Splices > Quick Disconnects



Quick Disconnect Terminal Type: **Receptacle**

Wire Size: .32 – .82 mm²

Mating Tab Width: 6.35 mm [.25 in]

Mating Tab Thickness: .81 mm [.032 in]

Features

Product Type Features

Terminal Features	Wire Stop
Insertion Force	Normal

Configuration Features

Connection Capacity	Single
Compatible With Wire & Cable Type	Discrete Wire

Body Features

Insulation Material	Nylon
---------------------	-------

Contact Features

Quick Disconnect Terminal Type	Receptacle
Mating Tab Width	6.35 mm [.25 in]
Mating Tab Thickness	.81 mm [.032 in]
Terminal Orientation	Straight
Contact Base Material	Phosphor Bronze
Terminal Plating Material	Tin



Crimp Type	F-Crimp
------------	---------

Barrel Type	Closed
-------------	--------

Termination Features

Product Terminates To	Wire & Cable
-----------------------	--------------

Mechanical Attachment

Wire Insulation Support	With
-------------------------	------

Mating Retention Type	Dimple
-----------------------	--------

Dimensions

Terminal Material Thickness	.41 mm[.016 in]
-----------------------------	-----------------

Product Length	21.75 mm[.856 in]
----------------	-------------------

Compatible Insulation Diameter Range	3.43 mm[.135 in]
--------------------------------------	------------------

Wire Size	.32 – .82 mm ²
-----------	---------------------------

Usage Conditions

Insulation Option	Fully Insulated
-------------------	-----------------

Operating Temperature Range	-40 – 110 °C[-40 – 230 °F]
-----------------------------	----------------------------

Industry Standards

Compatible With Agency/Standards Products	UL
---	----

UL Flammability Rating	UL 94V-2
------------------------	----------

Packaging Features

Packaging Quantity	2200
--------------------	------

Packaging Method	Strip/Reel
------------------	------------

Other

Barrel Color	Red
--------------	-----

Product Compliance

[For compliance documentation, visit the product page on TE.com>](#)

EU RoHS Directive 2011/65/EU	Compliant
------------------------------	-----------

EU ELV Directive 2000/53/EC	Compliant
-----------------------------	-----------

China RoHS 2 Directive MIIT Order No 32, 2016	No Restricted Materials Above Threshold
---	---

EU REACH Regulation (EC) No. 1907/2006	Current ECHA Candidate List: JUNE 2024 (241) Candidate List Declared Against: JAN 2024 (240)
--	---



Does not contain REACH SVHC

Halogen Content

Low Halogen - Br, Cl, F, I < 900 ppm per homogenous material. Also BFR/CFR/PVC Free

Solder Process Capability

Not applicable for solder process capability

Product Compliance Disclaimer

This information is provided based on reasonable inquiry of our suppliers and represents our current actual knowledge based on the information they provided. This information is subject to change. The part numbers that TE has identified as EU RoHS compliant have a maximum concentration of 0.1% by weight in homogenous materials for lead, hexavalent chromium, mercury, PBB, PBDE, DBP, BBP, DEHP, DIBP, and 0.01% for cadmium, or qualify for an exemption to these limits as defined in the Annexes of Directive 2011/65/EU (RoHS2). Finished electrical and electronic equipment products will be CE marked as required by Directive 2011/65/EU. Components may not be CE marked. Additionally, the part numbers that TE has identified as EU ELV compliant have a maximum concentration of 0.1% by weight in homogenous materials for lead, hexavalent chromium, and mercury, and 0.01% for cadmium, or qualify for an exemption to these limits as defined in the Annexes of Directive 2000/53/EC (ELV). Regarding the REACH Regulation, the information TE provides on SVHC in articles for this part number is based on the latest European Chemicals Agency (ECHA) 'Guidance on requirements for substances in articles' posted at this URL: <https://echa.europa.eu/guidance-documents/guidance-on-reach>

Compatible Parts

TE Part # 58628-1
PROCrimp T&D 26-14 ULTRAFast

TE Part # 90390-3
Dies Ultra-Fast Faston 22-18 Die Set

TE Part # 58628-2
PROCrimp DieSet 26-14 ULTRAFast

TE Part # 2151034-2
OCEAN_2.0 Applicator-S-1760-SSA

KIT
REPRESENTATION ONLY

TE Part # 7-2151034-7
OCEAN_2.0 Spare Part Kit-1760

Also in the Series | [Ultra-Fast 250](#)



Automotive Connector Caps & Covers (1)



Automotive Housings(5)



Quick Disconnects(49)

Customers Also Bought



TE Part #8-34124-1
TERM,SOLIS R 16-14 1/4

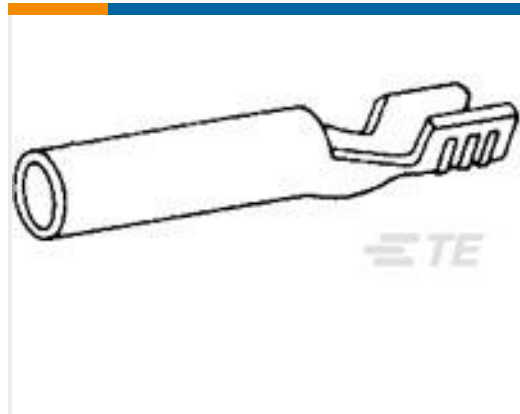

TE Part #63381-1
PIN .125 TERMINAL REC 22-18 AWG BR

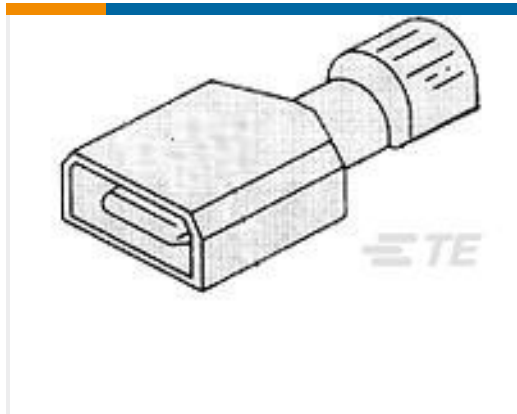

TE Part #2-520102-2
ULTRA-FAST 250 ASSEMBLY TAB 22-18 AWG BR



TE Part #62718-2
250 FASTON FLAG REC 22-18 AWG TPBR

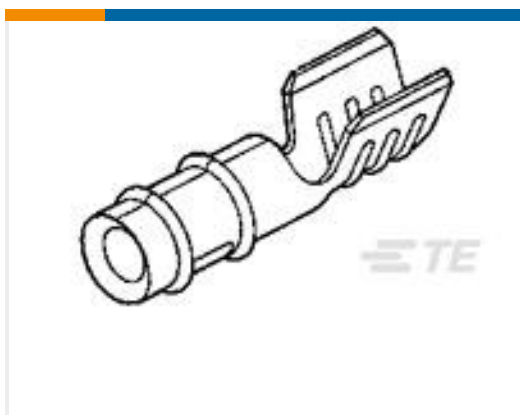

TE Part #350015-2
.093 PIN RECPT 22-18 PTPPHBRZ



TE Part #42938-2
RING 16-14 AWG TPBR

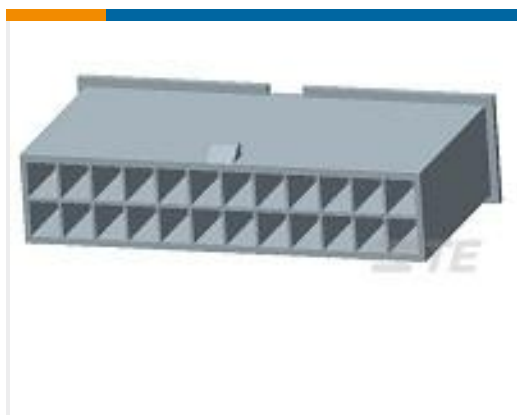

TE Part #1969612-6
6P FH PLUG VAL-U-LOK V0



TE Part #3-2176366-5
RQ 0603 976R 0.1% 10PPM 1K RL



TE Part #3-829868-8
DUOPLUG 2.5 FEDERLEI 8P



TE Part #1520230-1
7402K3=20 AMP TOGGLE

Documents

Product Drawings

[ULTRA-FAST 250 ASY REC 22-18 TPPB](#)

English

CAD Files

[3D PDF](#)

3D

[Customer View Model](#)

[ENG_CVM_CVM_2-520183-4_V.2d_dxf.zip](#)



English

Customer View Model

[ENG_CVM_CVM_2-520183-4_V.3d_igs.zip](#)

English

Customer View Model

[ENG_CVM_CVM_2-520183-4_V.3d_stp.zip](#)

English

By downloading the CAD file I accept and agree to the [Terms and Conditions](#) of use.

Datasheets & Catalog Pages

[Ultra-Fast and Ultra Fast Plus](#)

English

Product Specifications

[Application Specification](#)

English

Agency Approvals

[UL](#)

English