

Ultra Low Noise Rail-to-Rail I/O CMOS Precision OPERATIONAL AMPLIFIERS

GENERAL DESCRIPTION

The AD855X family represents a new generation of low-noise operational amplifiers, offering outstanding dc precision and ac performance. Rail-to-Rail input and output, low offset (2 μ V), low noise (6nV/Hz), quiescent current of 600 μ A, and a 6MHz bandwidth make this part very attractive for a variety of precision and portable applications. In addition, this device has a reasonably wide supply range (2V to 5.5V) with excellent PSRR making it attractive for applications that run directly from batteries without regulation.

The AD8551 (single), AD8552 (dual) and AD8554 (quad) families of operational amplifiers are specified for operation from -25°C to +85°C.



FEATURES

- Input Offset Voltage: 2 μ V (Typical)
- ZeroDrift: 0.03 μ V/C (Typical)
- Ultra Low Noise: 6nV/√Hz at 1kHz
- Supply Range: 2V to 5.5V
- Gain Bandwidth: 6-MHz
- Slew rate: 5V/μs
- Quiescent current: 600 μ A (Vs=5V)
- Rail-to-Rail Input and Output
- Micro size Packages:
AD8551 : SOT-23-5
AD8552ARZ: SOP-8
AD8554ARZ: SOP-14

APPLICATIONS

- ADC Buffer
- Audio Equipment
- Medical Instrumentation
- Handheld Test Equipment
- Active Filtering
- Sensor Signal Conditioning

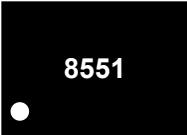
Reference News

MODEL	Op Temp(°C)	PACKAGE	Marking	QTY(PCS)
AD8551	-25°C~85°C	SOT23-5		3000
AD8552ARZ	-25°C~85°C	SOP-8		2500
AD8554ARZ	-25°C~85°C	SOP-14		2500

TYPICAL APPLICATION

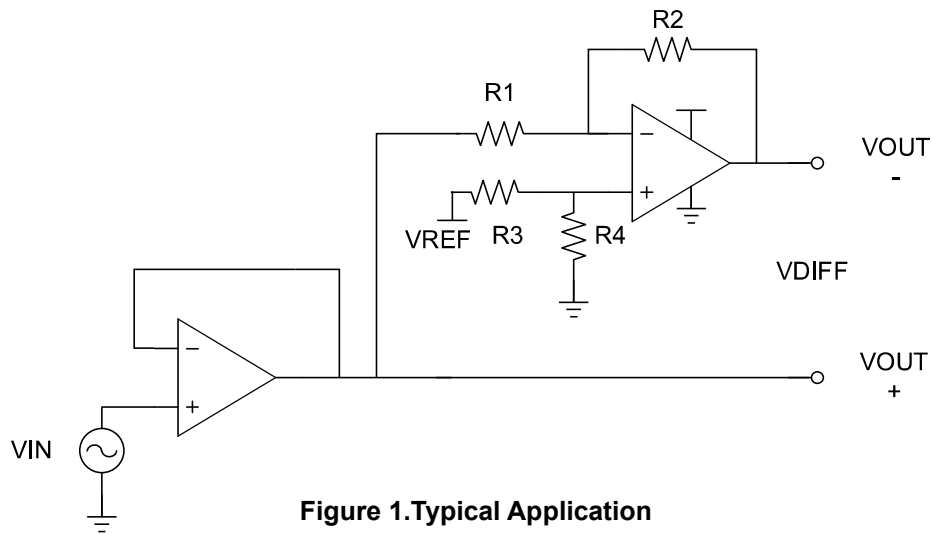
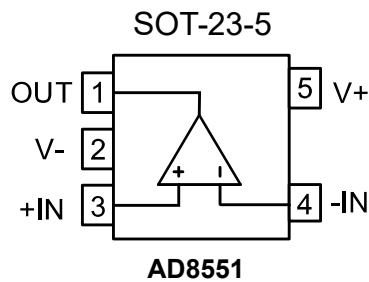

Figure 1. Typical Application

Pin Configuration and Functions (Top View) Pin Description



PIN		I/O	DESCRIPTION
NAME	Number		
+IN	3	I	Positive (noninverting) input
-IN	4	I	Negative (inverting) input
OUT	1	O	Output
V-	2	-	Positive (highest) power supply
V+	5	-	Negative (lowest) power supply

Pin Configuration and Functions (Top View) Pin Description

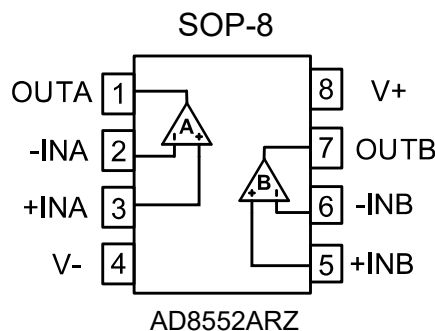

PIN		I/O	DESCRIPTION
NAME	Number		
+INA	3		Noninverting input, channel A
+INB	5		Noninverting input, channel B
-INA	2		Inverting input, channel A
-INB	6		Inverting input, channel B
OUTA	1	0	Output, channel A
OUTB	7	0	Output, channel B
V-	4	—	Negative (lowest) power supply
V+	8	—	Positive (highest) power supply

Pin Configuration and Functions (Top View)

Pin Description

SOP-14

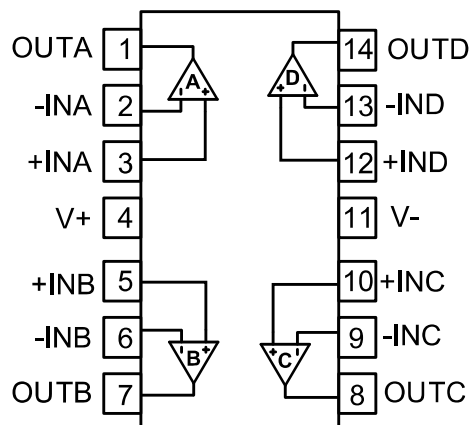

AD8554ARZ

PIN		I/O	DESCRIPTION
NAME	Number		
+INA	3		Noninverting input, channel A
+INB	5		Noninverting input, channel B
+INC	10		Noninverting input, channel C
+IND	12		Noninverting input, channel D
-INA	2		Inverting input, channel A
-INB	6		Inverting input, channel B
-INC	9		Inverting input, channel C
-IND	13		Inverting input, channel D
OUTA	1	0	Output, channel A
OUTB	7	0	Output, channel B
OUTC	8	0	Output, channel C
OUTD	14	0	Output, channel D
V-	4		Negative (lowest) power supply
V+	11	—	Positive (highest) power supply

SPECIFICATIONS

Absolute Maximum Ratings⁽¹⁾

		MIN	MAX	UNIT
Voltage	Supply Voltage		6	V
	Signal Input Terminals Voltage ⁽²⁾	(V-) - 0.5	(V+) + 0.5	V
	Signal Input Terminals Voltage ⁽³⁾	(V-) - 0.5	(V+) + 0.5	V
Current	Signal Input Terminals Current ⁽²⁾	-10	10	mA
	Signal output Terminals Current ⁽³⁾	-200	200	mA
	Output Short-Circuit ⁽⁴⁾	Continuous		
θ_{JA}	Operating Temperature Range	-25	85	°C
	Storage Temperature Range	-65	150	°C
	Junction Temperature	-40	150	°C

(1) Stresses above these ratings may cause permanent damage. Exposure to absolute maximum conditions for extended periods may degrade device reliability. These are stress ratings only, and functional operation of the device at these or any other conditions beyond those specified is not implied.

(2) Input terminals are diode clamped to the power-supply rails. Input signals that can swing more than 0.5V beyond the supply rails should be current limited to 10mA or less.

(3) Output terminals are diode-clamped to the power-supply rails. Output signals that can swing more than 0.5V beyond the supply rails should be current-limited to ± 200 mA or less.

(4) Short-circuit to ground, one amplifier per package.

ESD Ratings

			VALUE	UNIT
$V_{(ESD)}$	Electrostatic discharge	Human-Body Model (HBM)	± 4000	V
		Charged-Device Model (CDM)	± 500	V
		Machine Model	100	V

Recommended Operating Conditions

		MIN	MAX	UNIT
Supply voltage, $V_s = (V+) - (V-)$	Single-supply	2	5.5	V
	Dual-supply	± 1	± 2.75	V

ELECTRICAL CHARACTERISTICS ($V_S = +5V$)

At $T_A = 25^\circ C$, $V_{CM} = V_{OUT} = V_S / 2$, unless otherwise noted.

PARAMETER	CONDITIONS	MIN	TYP	MAX	UNIT	
OFFSET VOLTAGE						
V_{OS}	Input Offset Voltage		2	10	μV	
dV_{OS}/dT	Input Offset Voltage Average Drift	$T_A = -25^\circ C$ to $85^\circ C$	0.03		$\mu V/^\circ C$	
INPUT CURRENT						
I_B	Input Bias Current		500		μA	
I_{OS}	Input Offset Current		50		μA	
NOISE						
V_N	Input Voltage Noise	$f=0.1Hz$ to $10Hz$	0.3		μV_{PP}	
e_n	Input Voltage Noise Density	$f=1kHz$	6		nV/\sqrt{Hz}	
INPUT VOLTAGE						
V_{CM}	Common-Mode Voltage Range		$V_S - 0.1$	$V_S + 0.1$	V	
CMRR	Common-Mode Rejection Ratio	$V_{CM}=0.1V$ to $4V$	110	130	dB	
FREQUENCY RESPONSE						
GBW	Gain-Bandwidth Product	$C_L=100pF$		6	MHz	
SR	Slew Rate	$G = +1$, $V_{IN}=2V$ Step		5	V/us	
t_s	Settling Time to 0.1%	$G = +1$, $V_{IN}=2V$ Step		0.7	us	
THD+N	Total Harmonic Distortion +Noise	$G=1, V_O=1V_{RMS}$, $f=1kHz, R_L=10k\Omega$		0.0004	%	
OUTPUT						
A_V	Open-Loop Voltage Gain	$V_{OUT}=0.1V$ to $4.9V$ $R_L=10k\Omega$	135	150	dB	
V_{OH}	High output voltage swing	$R_L=10k\Omega$		10	20	mV
		$R_L=2k\Omega$		50	60	mV

V_{OL}	Low output voltage swing	$R_L=10k\Omega$		10	20	mV
		$R_L=2k\Omega$		35	45	mV
I_{SC}	Output Short-Circuit Current	Source current		30		mA
		Sink current		65		mA
$C_L^{(1)}$	Capacitive Load Drive	$G = +1,$ $V_{IN}=0.2V$ Step			560	pF
POWER SUPPLY						
PSRR	Power-Supply Rejection Ratio	$V_S=2.0V$ to $5.5V$	110	130		dB
V_S	Operating Voltage Range		2		5.5	V
I_Q	Quiescent Current/Amplifier	$I_O=0A$		600	700	μA

(1) Capacitive load drive means that above a given maximum value, the output waveform will oscillate under the step response.

TYPICAL CHARACTERISTICS

At $T_A = 25^\circ\text{C}$, $V_S = +5\text{V}$, $G=+1$, $V_{IN}=V_{OUT}= V_S / 2$, unless otherwise noted.

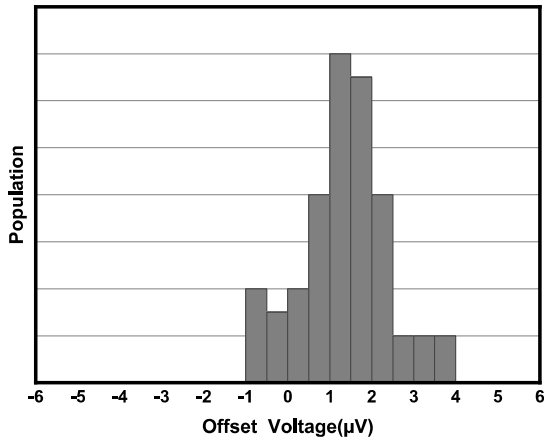

Figure 2. Offset Voltage Production Distribution

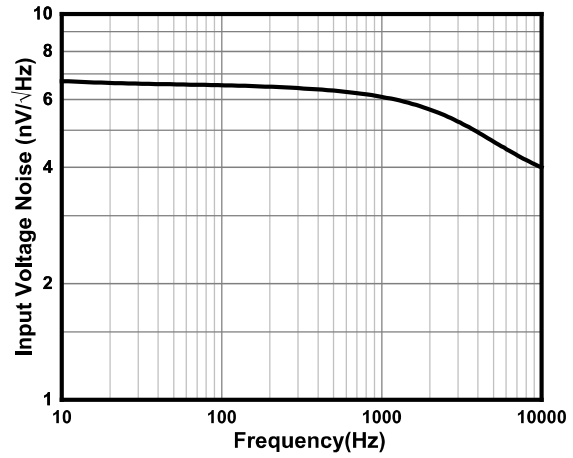

Figure 3. Input Voltage Noise Spectral Density

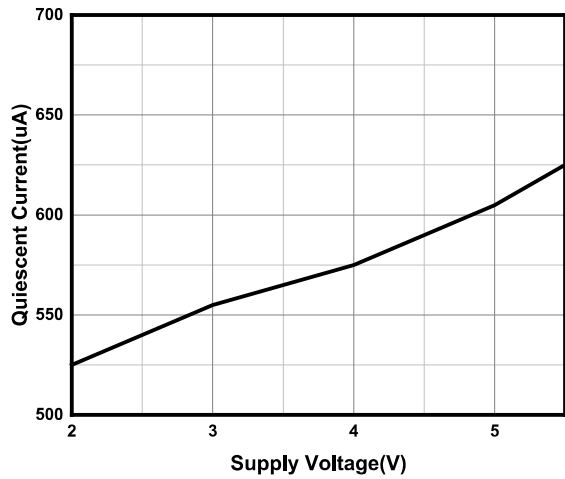

Figure 4. Quiescent Current vs Supply Voltage

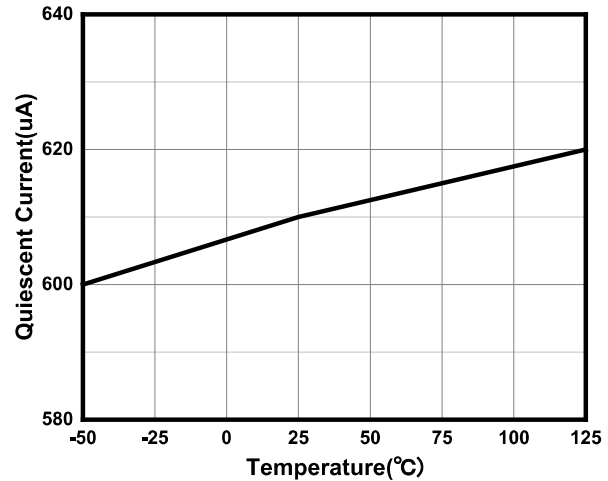

Figure 5. Quiescent Current vs Temperature

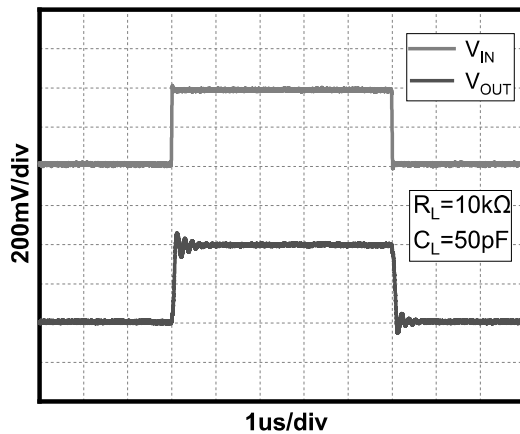

Figure 6. Small-Signal Step Response ($V_S=5\text{V}$)

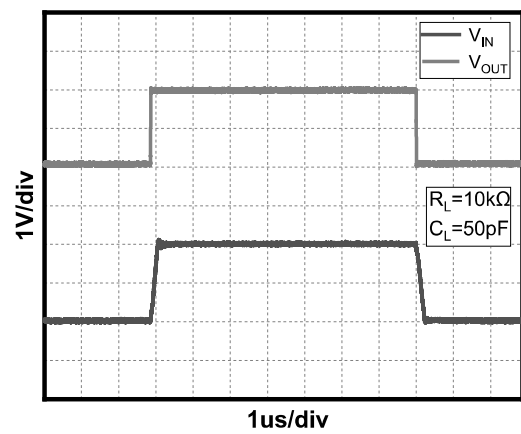

Figure 7. Large-Signal Step Response ($V_S=5\text{V}$)

TYPICAL CHARACTERISTICS

At $T_A = 25^\circ\text{C}$, $V_S = +5\text{V}$, $G=+1$, $V_{IN}=V_{OUT}= V_S / 2$, unless otherwise noted.

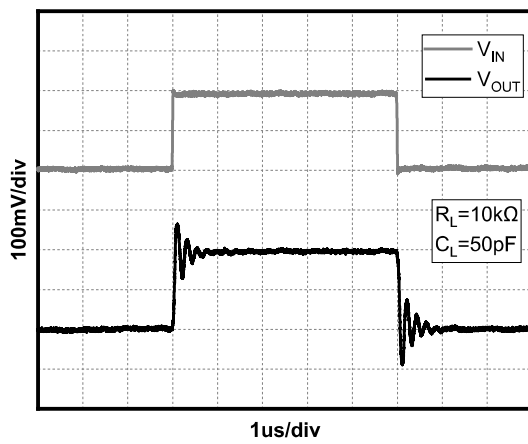

Figure 8. Small-Signal Step Response($V_S=2\text{V}$)

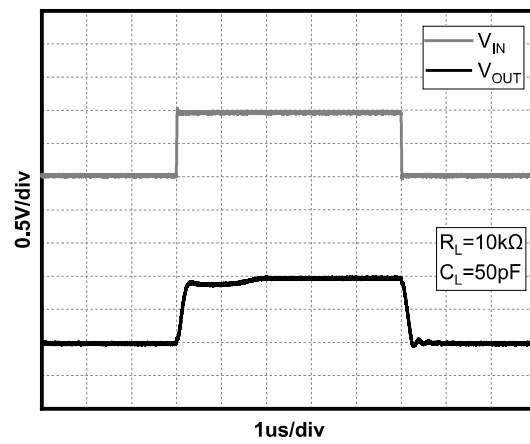

Figure 9. Large-Signal Step Response($V_S=2\text{V}$)

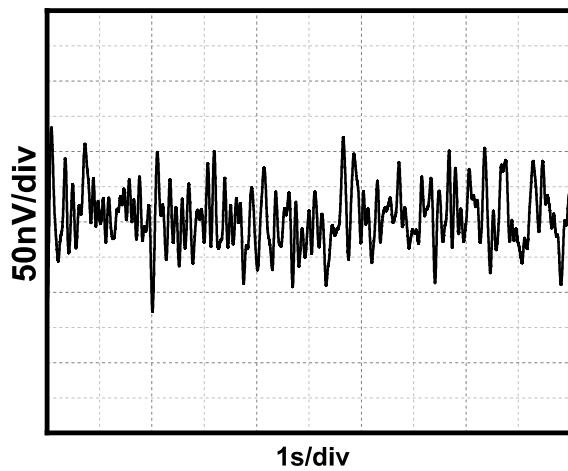

Figure 10. 0.1Hz to 10Hz Noise

Detailed Description

Overview

The AD8551 / AD8552 / AD8554 devices are a low noise, unity-gain stable, rail-to-rail precision operational amplifier that operate in a single-supply voltage range of 2V to 5.5V ($\pm 1V$ to $\pm 2.75V$). A high supply voltage of 6V (absolute maximum) can permanently damage the amplifier. Rail-to-rail input and output wobbles significantly increase the dynamic range, especially in low-supply applications. Good layout practices require that a 0.1 μ F capacitor be used where it is tightly threaded through the power supply pin.

Phase Reversal Protection

The AD8551 / AD8552 / AD8554 devices have internal phase-reversal protection. Many op exhibit phase reversal when the input is driven beyond the linear common-mode range. This condition is most often encountered in noninverting circuits when the input is driven beyond the specified common-mode voltage range, causing the output to reverse into the opposite rail. The input of the AD8551 / AD8552 / AD8554 prevents phase reversal with excessive common mode voltage. Instead, the appropriate rail limits the output voltage.

Typical Applications

1 Voltage Follower

As shown in Figure 11, the voltage gain is 1. With this circuit, the output voltage V_{out} is configured to be equal to the input voltage V_{in} . Due to the high input impedance and low output impedance, the circuit can also stabilize the output voltage, the output voltage expression is

$$V_{out} = V_{in} \quad (1)$$

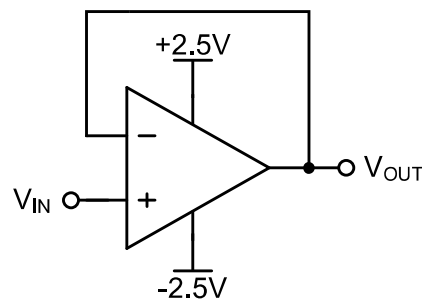

2 Inverting Proportional Amplifier

As shown in Figure 12, for a reverse-phase proportional amplifier, the input voltage V_{in} is amplified by a voltage gain that depends on the ratio of R_1 to R_2 . The output voltage V_{out} is inversely with the input voltage V_{in} . The input impedance of the circuit is equal to R_1 . and the output voltage expression is

$$V_{OUT} = -\frac{R_2}{R_1} V_{IN} \quad (2)$$

PACKAGE DESCRIPTION

SOT23-5

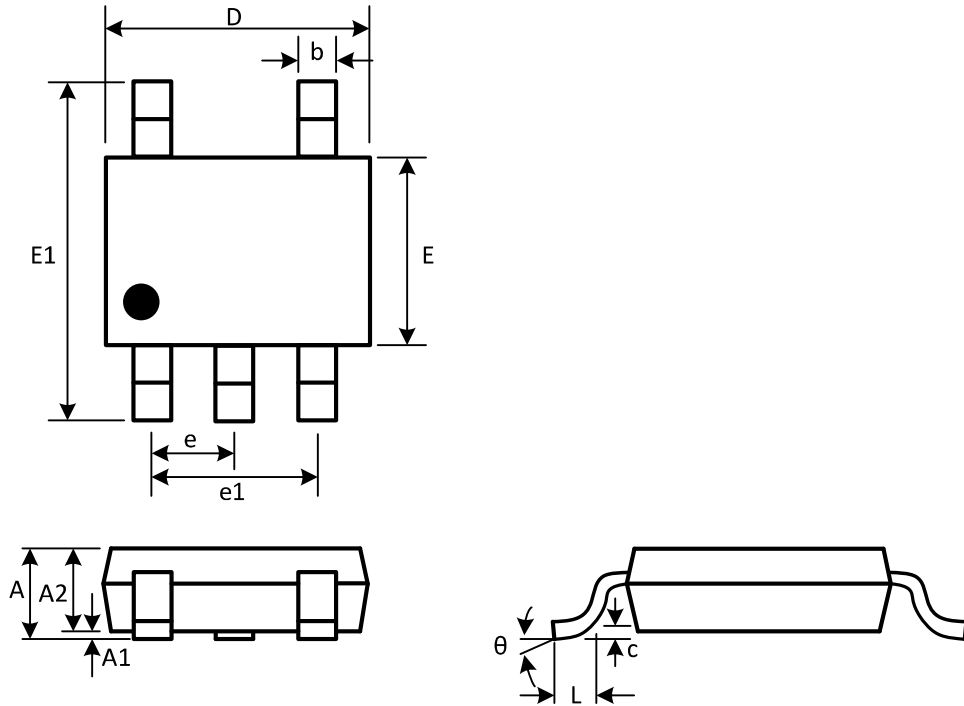

(Unit: mm)

Symbol	Min	Max
A	1.050	1.250
A1	0.000	0.100
A2	1.050	1.150
b	0.300	0.500
c	0.100	0.200
D	2.820	3.020
e	0.950(BSC)	
e1	1.800	2.000
E	1.500	1.700
E1	2.650	2.950
L	0.300	0.600
θ	0°	8°

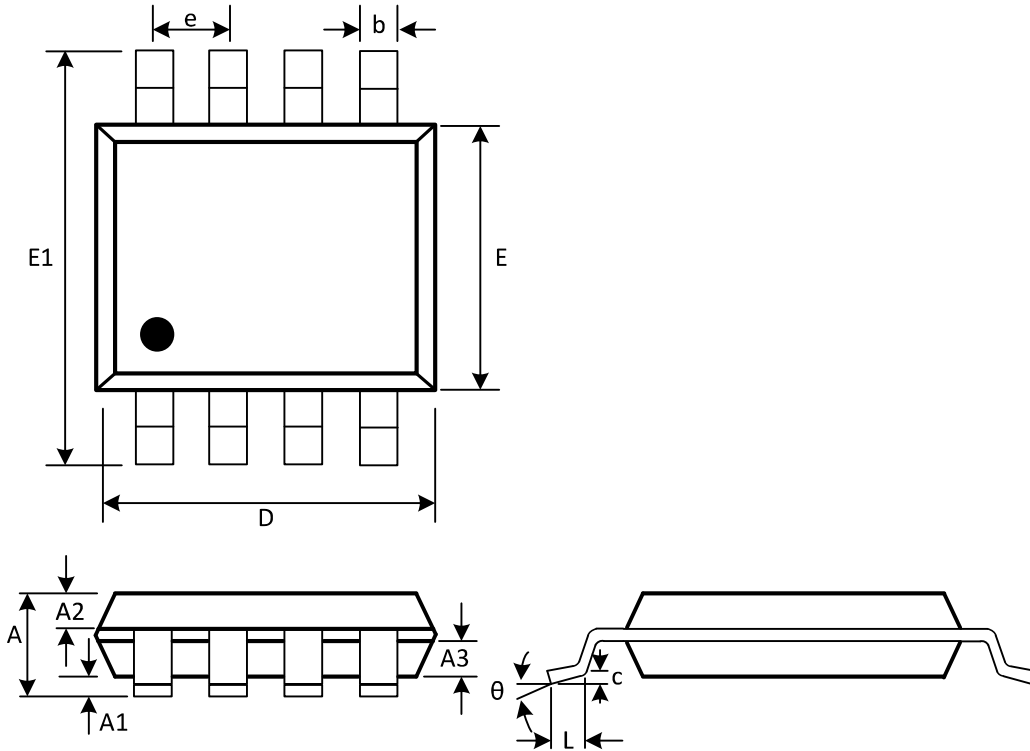

(Unit: mm)

Symbol	Min	Max
A	1.300	1.600
A1	0.050	0.200
A2	0.550	0.650
A3	0.550	0.650
b	0.356	0.456
c	0.203	0.233
D	4.800	5.000
e	1.270(BSC)	
E	3.800	4.000
E1	5.800	6.200
L	0.400	0.800
θ	0°	8°

SOP-14

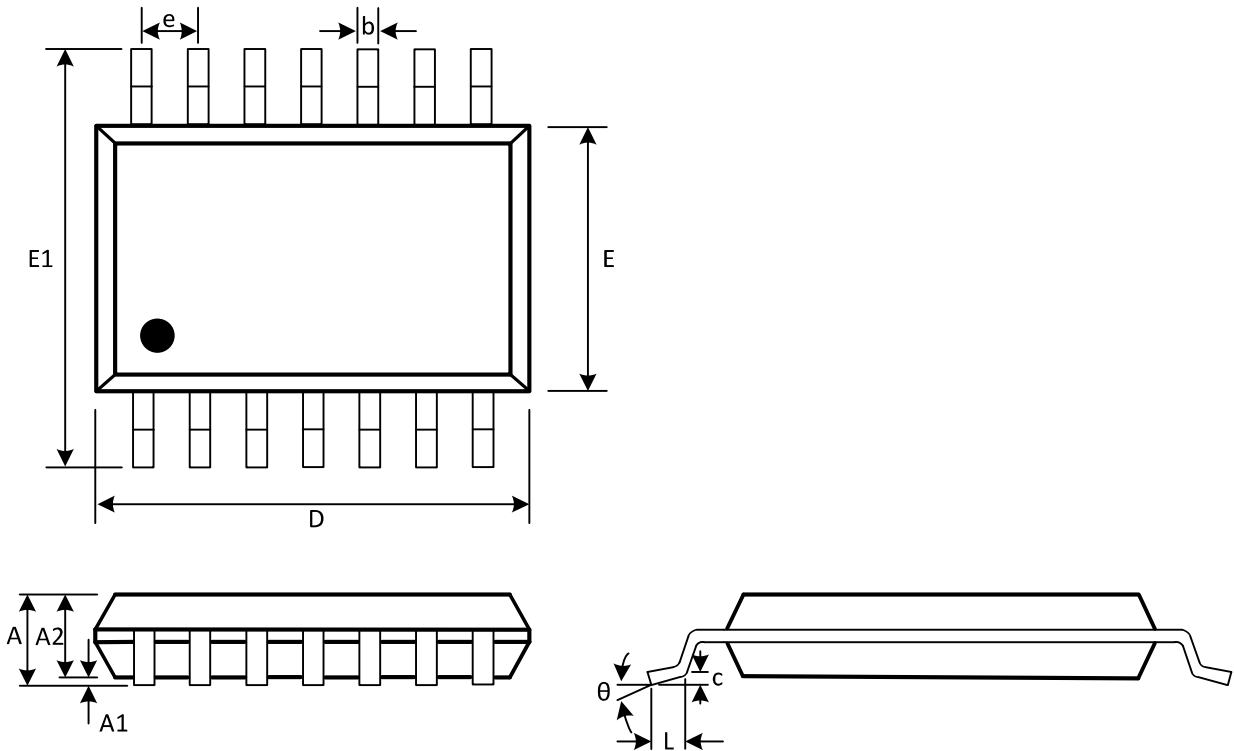

(Unit: mm)

Symbol	Min	Max
A	1.350	1.750
A1	0.100	0.250
A2	1.350	1.550
b	0.310	0.510
c	0.100	0.250
D	8.450	8.850
e	1.270(BSC)	
E	5.800	6.200
E1	3.800	4.000
L	0.400	1.270
θ	0°	8°