

V640 Series

Line-up Ethernet I/F model newly. RFID system for Semiconductor applications, supports reading and writing TI (Texas Instruments) transponders

- Conforms to RFID wireless interface standards (ISO/IEC 18000-2)
- Supports SEMI standards (E4, E5, E99, E15.1, E144-0312)
- Supports SECS commands (when using V700-L22-V2)
- Embedded Web browser function provides easy configuration and read/write testing (Ethernet type only)
- Enhanced functions, TEST Mode / Detecting for CIDRW Head status
- Certified as radio by many countries: the USA's FCC, EU R&TTE directive, Canada's IC, China, South Korea, Taiwan, Singapore, and Isreal.

Note: Update of radio certifications can be confirmed in the OMRON website.
<http://www.ia.omron.com/index.html>

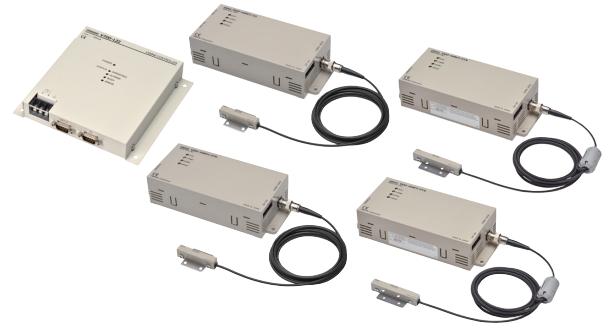

Be sure to read the "Safety Precautions" on page 6

System Configuration

Standard Models

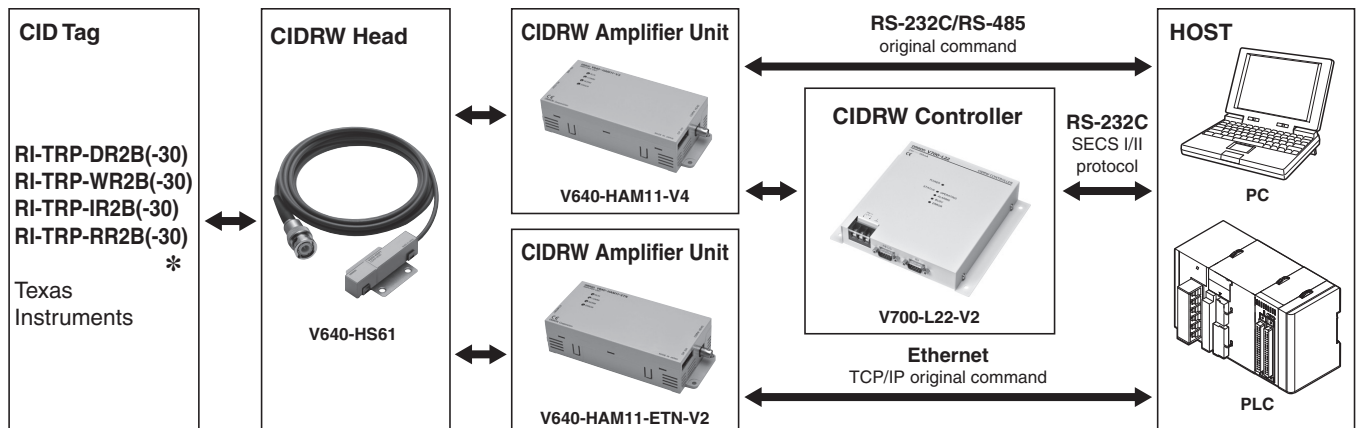

Long-range Communications Model

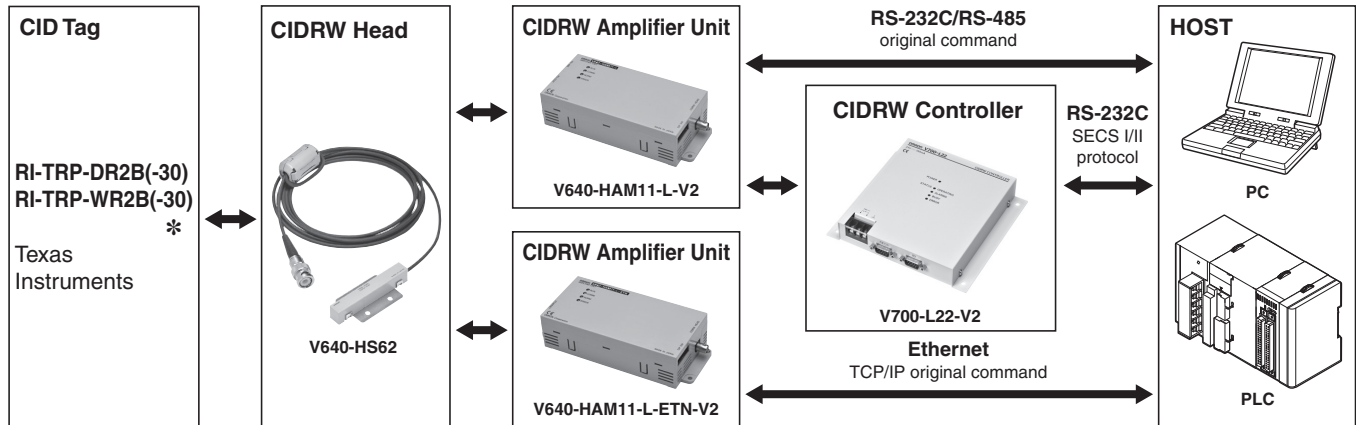

- Note:**
1. Use of the V700-L11 ID Link Unit enables the CIDRW Amplifier Unit to be removed/installed while the CIDRW System remains turned ON in the event of a malfunction or during maintenance.
 2. Use the V700-L22-V2 CIDRW Controller when using SECS communications protocol.
 3. For details, refer to the User's Manual. Confirm the Manual No. that is listed in Related Manuals.
- * Communication performance does not guarantee.

Ordering Information

List of Models

Name	Appearance	Size	Specifications	Model
CIDRW Head		50 × 30 × 12 mm (including mounting plate)	Standard Models 2-meter cable	V640-HS61 2M
		65 × 30 × 12 mm (including mounting plate)	Long-range Communications Model 1.9-meter cable	V640-HS62 1.9M
CIDRW Amplifier Unit		80 × 185 × 43 mm	RS-232C interface RS-485 interface 24 VDC	V640-HAM11-V4
		80 × 185 × 43 mm	Ethernet interface 24 VDC	V640-HAM11-ETN-V2
		80 × 185 × 43 mm	RS-232C interface RS-485 interface 24 VDC	V640-HAM11-L-V2
		80 × 185 × 43 mm	Ethernet interface 24 VDC	V640-HAM11-L-ETN-V2
CIDRW Controller		150 × 167 × 28 mm	24 VDC RS-232C interface (Compatible with SECS I/II protocol.)	V700-L22-V2
ID Link Unit		110 × 65 × 64 mm	24 VDC RS-232C interface RS-485 interface	V700-L11
Connector accessories for the V640 CIDRW Amplifier Unit		Power Supply Connector (1) Power Supply Connector Pins (3) RS-485 Port Connector (1)	}	V640-A90



* V640-A90 includes all of these accessories as a set. To purchase individual accessories, contact the manufacturers below directly.

Purchasing Individual Accessories





Name	Model	Manufacturer
Power Supply Connector	1-178288-3	Tyco Electronics
Power Supply Connector Pins	175217-3	
RS-485 Port Connector	MSTB2.5/2-STF-5.08	Phoenix Contact Inc.

Specifications and Ratings

CIDRW Head

Item	Model		
Transmission frequency	134 kHz		
Insulation resistance	20 MΩ min. (at 100 VDC) between the connector terminals and the case		
Dielectric strength	1,000 VAC (50/60 Hz, 1 minute) between the connector terminals and the case (leakage current: 5 mA max.)		
Vibration resistance	10 to 150 Hz, 0.20-mm double amplitude, 15-m/s ² acceleration with 10 sweeps of 8 min each in X, Y, and Z directions		
Shock resistance	150-m/s ² acceleration for 3 times each in X, Y, and Z directions (18 times in total)		
Ambient operating temperature	0 to 40°C (with no icing)		
Ambient operating humidity	35% to 85% (with no condensation)		
Ambient storage temperature	-15 to 65°C (with no icing)		
Ambient storage humidity	35% to 85% (with no condensation)		
Degree of protection	IEC60529: IP20		
Cable	2-m (3-mm dia.) coaxial cable		1.9-m (3-mm dia.) coaxial cable
Case	ABS/epoxy resin, stainless-steel mounting fixture		
Weight	Approx. 70 g		Approx. 100 g

CIDRW Amplifier Unit

Item	Model				
Host interface	RS-232C/RS-485			Ethernet (TCP/IP)	
Power supply voltage	24 VDC (max. fluctuation 20.4 to 26.4 VDC)				
Current consumption	150mA or less	400mA or less	150mA or less	400mA or less	
Insulation resistance	20 MΩ min. (at 100 VDC) between the power supply terminals and the frame ground terminal				
Dielectric strength	1,000 VAC (50/60 Hz, 1 minute) between the power supply terminals and the frame ground terminal (leakage current: 5 mA max.)				
Vibration resistance	10 to 150 Hz, 0.20-mm double amplitude, 15-m/s ² acceleration with 10 sweeps of 8 min each in X, Y, and Z directions				
Shock resistance	150-m/s ² acceleration for 3 times each in X, Y, and Z directions (18 times in total)				
Ambient operating temperature	0 to 40°C (with no icing)				
Ambient operating humidity	35% to 85% (with no condensation)				
Ambient storage temperature	-15 to 65°C (with no icing)				
Ambient storage humidity	35% to 85% (with no condensation)				
Degree of protection	IEC60529: IP20				
Case	ABS+PC				
Ground	Ground at a resistance of less than 100 Ω.				
Weight	Approx. 250 g				
Wireless interface standards	ISO/IEC 18000-2 and SEMI E144-0312				

CIDRW Controller

Item	Model
	V700-L22-V2 
Host interface	RS-232C
Power supply voltage	24 VDC (max. fluctuation 20.4 to 26.4 VDC)
Current consumption	150 mA or less
Insulation resistance	50 MΩ min. (at 500 VDC) between the power supply terminals and the frame ground terminal
Dielectric strength	500 VAC (50/60 Hz, 1 minute) between the power supply terminals and the ground terminal
Vibration resistance	10 to 150 Hz, 0.20-mm double amplitude, 15-m/s ² acceleration with 10 sweeps of 8 min each in X, Y, and Z directions
Shock resistance	150-m/s ² acceleration for 3 times each in X, Y, and Z directions (18 times in total)
Ambient operating temperature	0 to 40°C (with no icing)
Ambient operating humidity	10% to 85% (with no condensation)
Ambient storage temperature	-15 to 65°C (with no icing)
Ambient storage humidity	10% to 95% (with no condensation)
Degree of protection	IEC60529: IP20
Ground	Ground at a resistance of less than 100 Ω.
Case	SECC (coating)
Weight	Approx. 560 g

ID Link Unit

Item	Model
	V700-L11 
Host interface	RS-232C or RS-485
Power supply voltage	24 VDC (max. fluctuation 20.4 to 26.4 VDC)
Current consumption	250 mA or less
Insulation resistance	50 MΩ min. (at 500 VDC) between the power supply terminals and the frame ground terminal
Dielectric strength	1,000 VAC (50/60 Hz, 1 minute) between the power supply terminals and the frame ground terminal (leakage current: 5 mA max.)
Vibration resistance	10 to 150 Hz, 0.20-mm double amplitude, 15-m/s ² acceleration with 10 sweeps of 8 min each in X, Y, and Z directions
Shock resistance	150-m/s ² acceleration for 3 times each in X, Y, and Z directions (18 times in total)
Ambient operating temperature	0 to 40°C (with no icing)
Ambient operating humidity	35% to 85% (with no condensation)
Ambient storage temperature	-15 to 50°C (with no icing)
Ambient storage humidity	35% to 85% (with no condensation)
Degree of protection	IEC60529: IP20
Ground	Ground at a resistance of less than 100 Ω. If grounding is not performed properly, transmission specifications may be adversely affected by the surrounding environment.
Case	PC/ABS resin
Weight	Approx. 200 g

Functional Specifications

Serial Type System Configuration Examples

System Configuration Using CIDRW Controller (V700-L22-V2)

The Carrier ID Reader Writer (CIDRW) System is an RFID system that conforms to SEMI standards. The V700-L22-V2 CIDRW Controller, the V640-HAM1 CIDRW Amplifier Unit, the V640-HS6 CIDRW Head, and a Texas Instruments CID Tag can be used to configure a Carrier ID Reader Writer (CIDRW) System that conforms to the following standards:

Note: SEMI: Semiconductor Equipment and Materials International
SECS: SEMI Equipment Communications Standard

CIDRW System

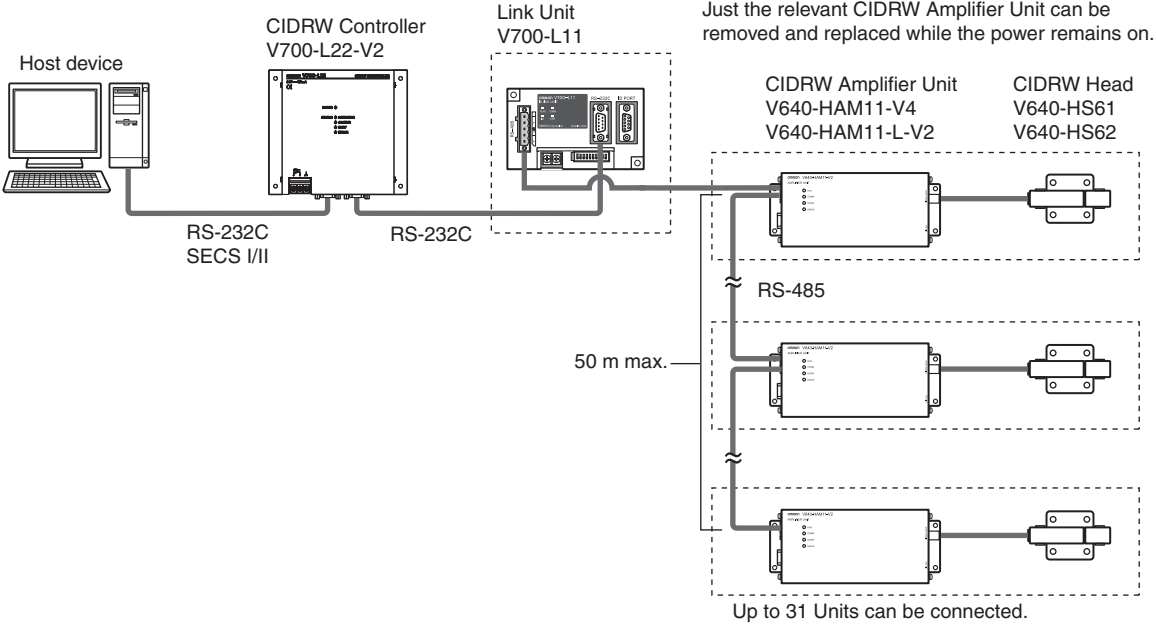

Ethernet Type System Configuration Examples

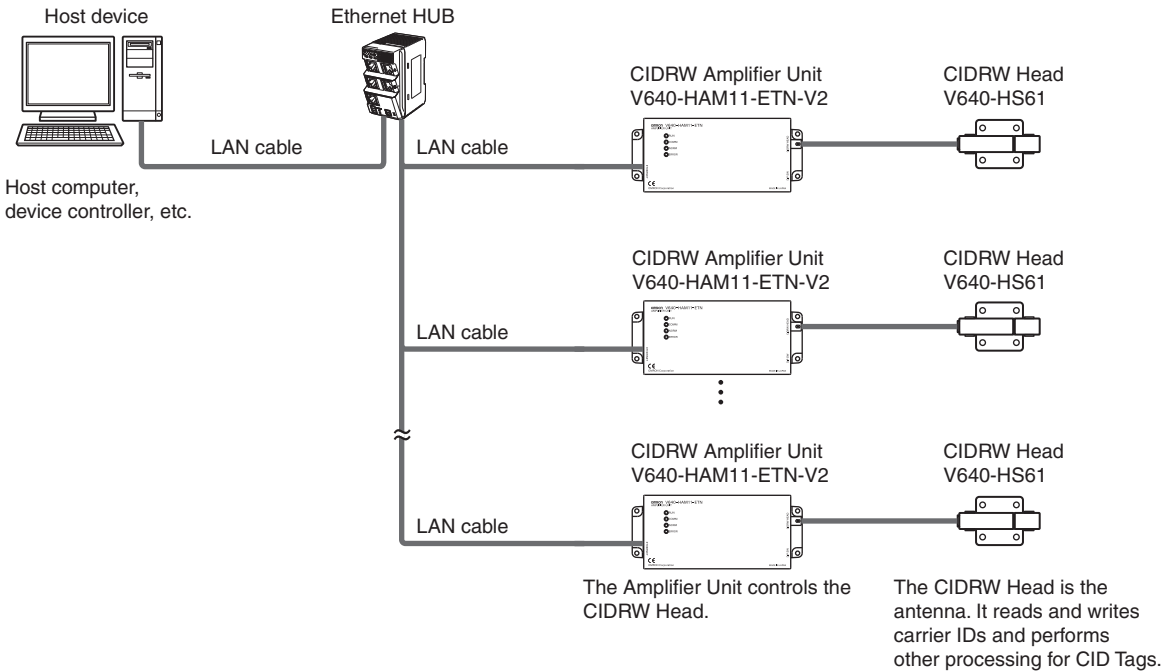

Note: If the IP address is set on the DIP switch, it will be in the form 192.168.1.□□□. The subnet mask is always 255.255.255.0. The IP address of the CIDRW Amplifier Unit can be either set on this DIP switch or the desired IP address can be set in ROM. If pins 1 to 5 on the DIP switch are all turned OFF, the IP address that is set in ROM will be used.

Safety Precautions

WARNING

The product is not designed or rated for ensuring safety of persons.
Do not use it for such purposes.



Precautions for Safe Use

Please observe the following precautions for safe use of the products.

- Never use the product in an environment where combustible or explosive gas is present.
- Please separate from a high-pressure equipment and the power equipment to secure the safety of the operation and maintenance.
- In the installation, please tighten the screw surely. (Recommended 1.2N.m)
- Please do not insert foreign bodies such as water and the wires from the space of the case.
- Please do not dismantle, repair or modify this product.
- Please process as industrial waste when you abandon this product.
- When you work on wiring and put on and take off cables, CIDRW head, please perform it after switching off this product.
- Provide enough space around this product for ventilation.
- Please avoid installing this product near the machinery (a heater, a transformer, large-capacity resistance) that has high the calorific value. When you felt abnormality to this product, and having switched it off.

Confirm the effects of radio waves on medical devices. The following guideline is from JAISA (Japan Automatic Identification Systems Association).

This product is a reader-writer that uses radio waves for RFID equipment. The application and location of this product may affect medical devices. The following precaution must be observed in the application of the product to minimize the effects on medical devices.

Any person with an implanted medical device must keep the area where the device is implanted at least 22 cm away from the antenna of a stationary or modular RFID device.

Precautions for Correct Use

Please observe the following precautions to prevent failure to operate, malfunctions, or undesirable effects on product performance.

About installation Site

Do not install this product in the locations subject to the following conditions.

- Place where direct sunshine strikes.
- Place with corroded gas, dust, metallic powder, and salinity.
- Place with condensation due to rapid temperature fluctuations.
- Place with condensation due to high humidity.
- Place where vibration and impact more than being provided by specification are transmitted directly to main body.
- Place with spray of water, oil, and chemical medicine.
- The working temperature is within the range stipulated in the specifications.

About depositoty Site

- Please follow the save ambient temperature / humidity, and keep this product.

About wiring

- Use the power supply voltage specified in this document.
- Ensure correct polarity when connecting to the +/- power supply terminals.
- Do not run high-voltage lines and power lines though the same conduit.
- To avoid static-induced failure, wear a wrist band or equivalent means to release a static charge before touching a terminal or a signal line within a connector.
- In using this product in EU association states, the cable for DC power supply to this product must not be extended over 3m.
- When you put on and take off a CIDRW head, please do not add excessive power to a connector.
- Please connect the correct CIDRW head to the CIDRW amplifier unit.

About cleaning

- Use alcohol to clean this product.
- Never use an organic solvent such as thinner, benzene, acetone or kerosene, as it will attack resin components or case coating.

Power and Ground Cables

- Use an appropriate ground. An insufficient ground can affect this product operation or result in damage to this product.

About the communication range and time

- Do the communication test with Transponder in the installation environment because the metal, noise and ambient temperature around CIDRW head damage to the communication range and time.
- Install CIDRW head and CID tag in the appropriate distance because the communication range can change by the difference of CID tag specifications.

About mounting

- This product communicates with CID Tags using the 134 kHz frequency band. Some transceivers, motors, monitoring equipment, and power supplies (power supply ICs) generate electrical waves (noise) that interfere with communications with CID Tags. If you are using the product in the vicinity of any of these devices, check the effect on communications in advance.
- In order to minimize the effects of noise, ground nearby metal bodies with a grounding resistance not exceeding 100 ohms.
- When mounting CIDRW Heads, tighten the screws tightly. (Recommended 0.6N·m)
- When multiple CIDRW Heads are mounted next to each other, communications performance could be impaired by mutual interference. Read and follow the information in User's Manual on mutual interference when installing multiple heads.

Screw Locking Adhesive

- Screw locking adhesive (screw lock) may cause deterioration and cracking of resin parts; do not use it for screws in resin parts or anywhere where resin washers are used.

Communications with the Host Device

(V640-HAM11-V4 and V680-HAM11-L-V2 only)

- Communicate with the host device only after confirming that the CIDRW Controller has started. Also, unstable signals may occur at the host interface when the CIDRW Controller is started. When initializing operation, clear the reception buffer at the host device or take other suitable methods to clear unwanted signals.

Startup Precaution

- Never turn OFF the power supply while the CIDRW Controller is starting, including when power is turned ON, when the mode is changed, or when the CIDRW Controller is being reset. Doing so may damage the CIDRW Controller.

Application Precaution

(V640-HAM11-ETN-V2 and V640-HAM11-L-ETN-V2 only)

- Never turn OFF the power supply while setting the IP address, subnet mask, or Web password. Doing so may damage the CIDRW Amplifier Unit.

Dimensions

CIDRW Head

V640-HS61

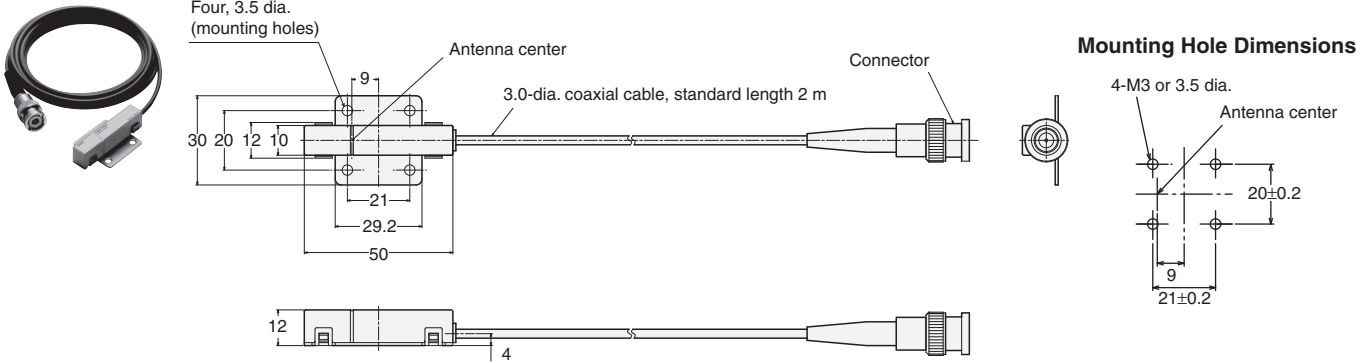

CIDRW Head

V640-HS62

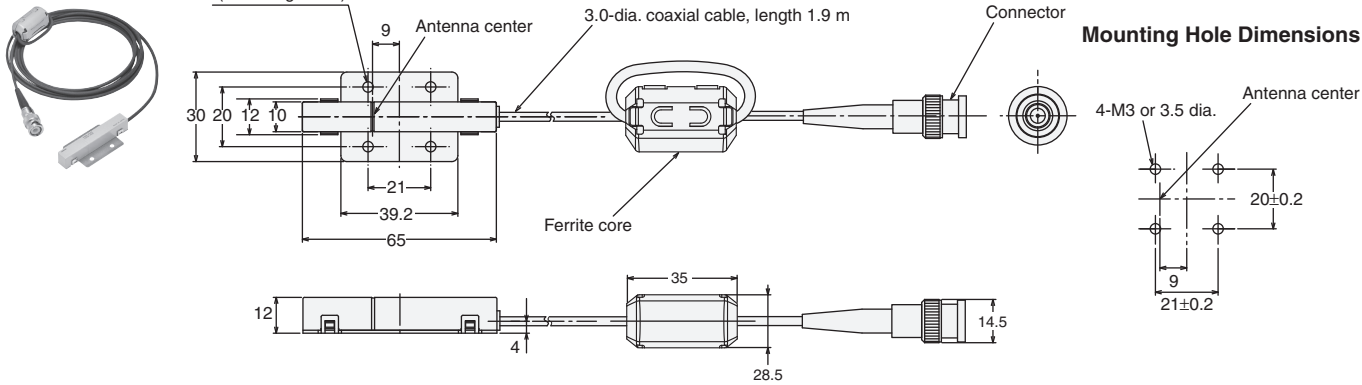

CIDRW Amplifier Unit

V640-HAM11-V4
V640-HAM11-L-V2

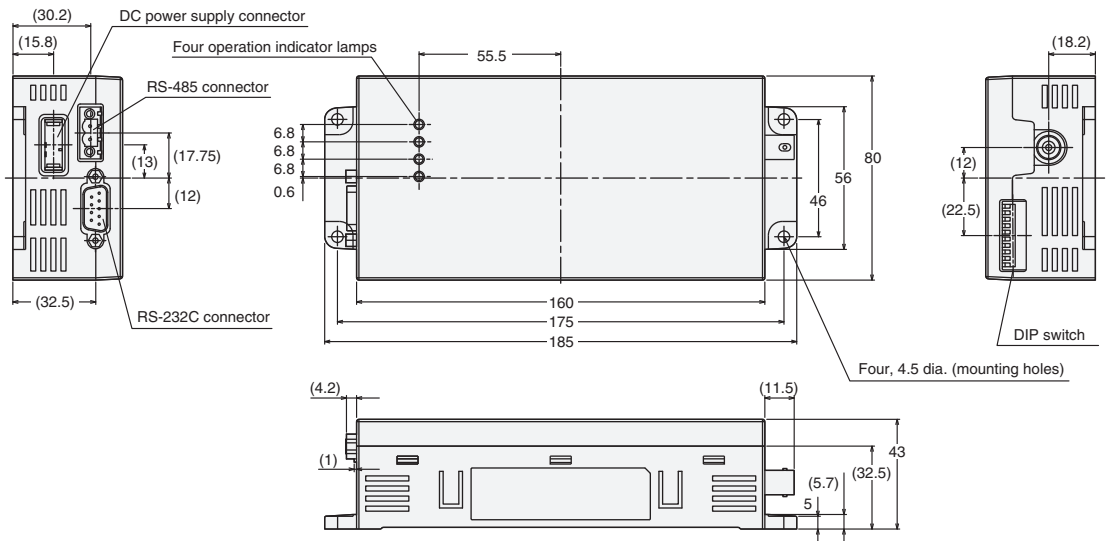

Mounting Hole Dimensions

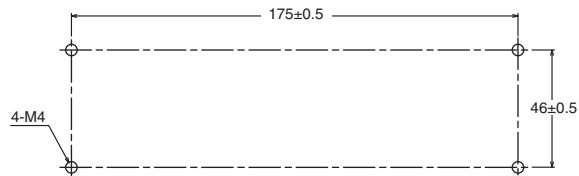

CIDRW Amplifier Unit

V640-HAM11-ETN-V2
V640-HAM11-L-ETN-V2

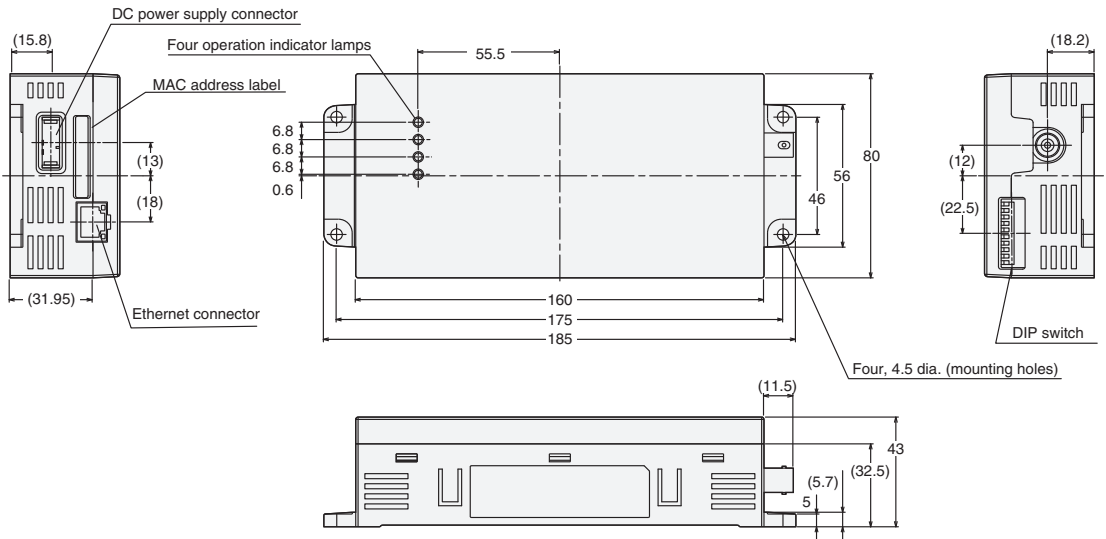

Mounting Hole Dimensions

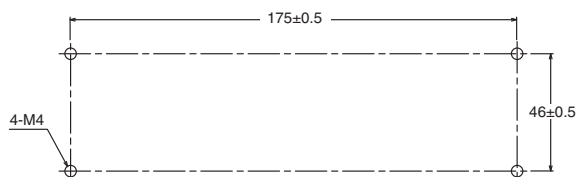

CIDRW Controller
V700-L22-V2

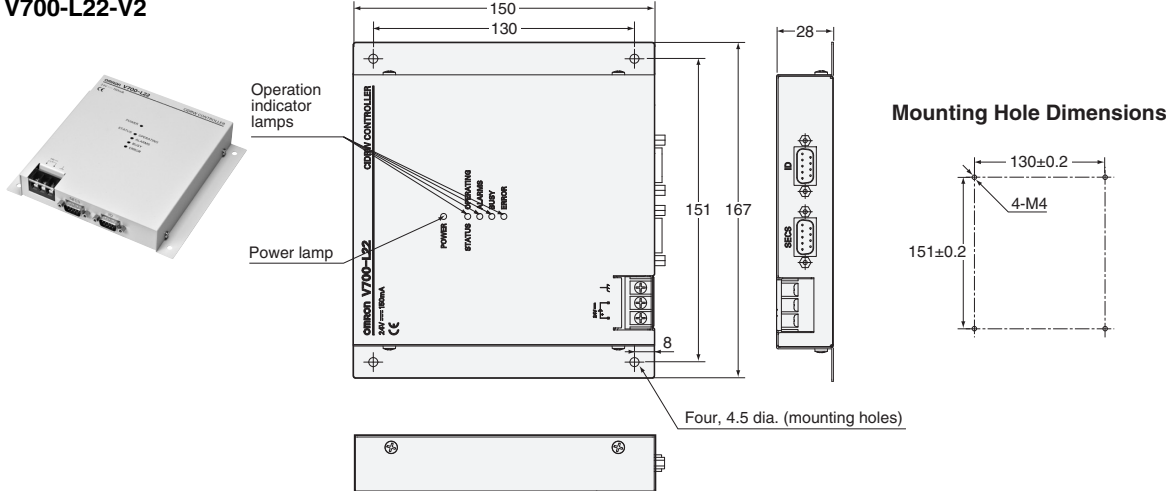

ID Link Unit
V700-L11

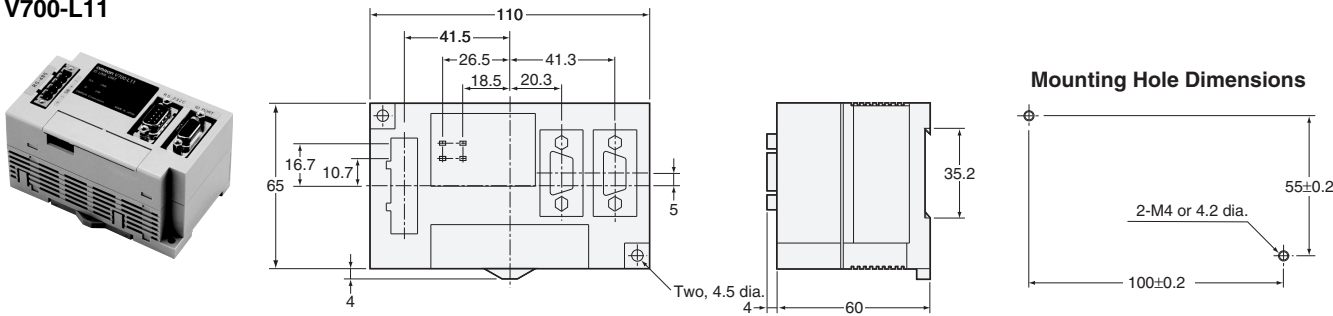

Related Manuals

English Cat.No.	Japanese Cat.No.	Model	Name
Z360-E1	SDGR-712	V640-HAM11-V4 V640-HAM11-L-V2 V640-HS61/HS62 V700-L11/L22 * /L22-V2	V640 Series User's Manual
Z361-E1	SDGR-713	V640-HAM11-ETN-V2 V640-HAM11-L-ETN-V2 V640-HS61 V640-HS62	V640 Series User's Manual

* Production was discontinued.

OMRON AUTOMATION AMERICAS HEADQUARTERS • Chicago, IL USA • 847.843.7900 • 800.556.6766 • automation.omron.com

OMRON CANADA, INC. • HEAD OFFICE

Toronto, ON, Canada • 416.286.6465 • 866.986.6766 • automation.omron.com

OMRON ELECTRONICS DE MEXICO • HEAD OFFICE

Ciudad de México • 52.55.5901.4300 • 01.800.386.6766 • mela@omron.com

OMRON ELECTRONICS DE MEXICO • SALES OFFICE

San Pedro Garza García, N.L. • 81.12.53.7392 • 01.800.386.6766 • mela@omron.com

OMRON ELECTRONICS DE MEXICO • SALES OFFICE

Eugenio Garza Sada, León, Gto • 01.800.386.6766 • mela@omron.com

OMRON ELETRÔNICA DO BRASIL LTDA • HEAD OFFICE

São Paulo, SP, Brasil • 55 11 5171-8920 • automation.omron.com

OMRON ARGENTINA • SALES OFFICE

Buenos Aires, Argentina • +54.11.4521.8630 • +54.11.4523.8483
mela@omron.com

OTHER OMRON LATIN AMERICA SALES

+54.11.4521.8630 • +54.11.4523.8483 • mela@omron.com

Authorized Distributor:

Controllers & I/O

- Machine Automation Controllers (MAC) • Motion Controllers
- Programmable Logic Controllers (PLC) • Temperature Controllers • Remote I/O

Robotics

- Industrial Robots • Mobile Robots

Operator Interfaces

- Human Machine Interface (HMI)

Motion & Drives

- Machine Automation Controllers (MAC) • Motion Controllers • Servo Systems
- Frequency Inverters

Vision, Measurement & Identification

- Vision Sensors & Systems • Measurement Sensors • Auto Identification Systems

Sensing

- Photoelectric Sensors • Fiber-Optic Sensors • Proximity Sensors
- Rotary Encoders • Ultrasonic Sensors

Safety

- Safety Light Curtains • Safety Laser Scanners • Programmable Safety Systems
- Safety Mats and Edges • Safety Door Switches • Emergency Stop Devices
- Safety Switches & Operator Controls • Safety Monitoring/Force-guided Relays

Control Components

- Power Supplies • Timers • Counters • Programmable Relays
- Digital Panel Meters • Monitoring Products

Switches & Relays

- Limit Switches • Pushbutton Switches • Electromechanical Relays
- Solid State Relays

Software

- Programming & Configuration • Runtime