

PART NUMBER	DIM "H"	NOTE
213780-0001	4.00± 0.3	

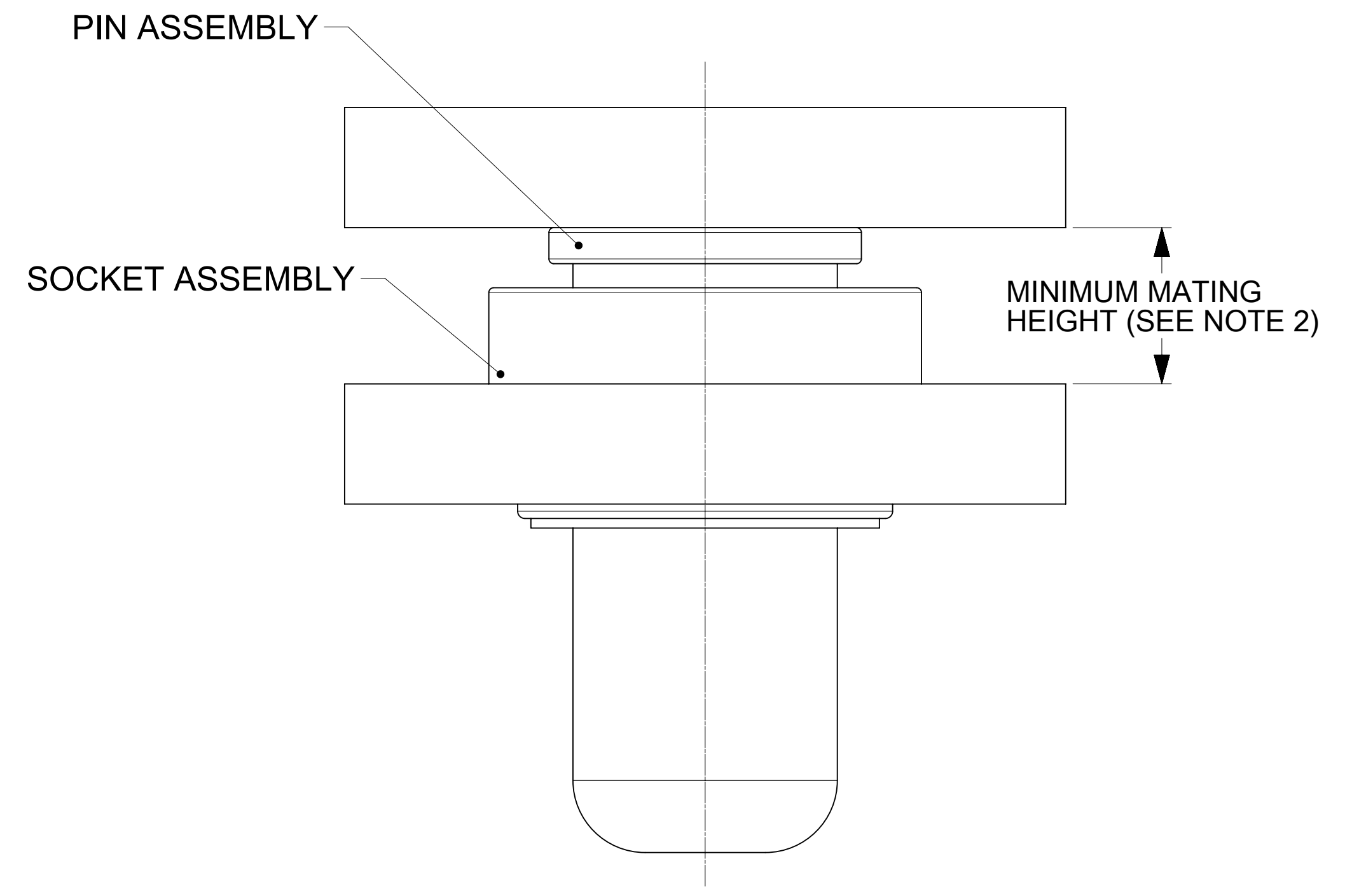

MATING PROFILE

- NOTES:
- MATERIALS:
 - RETENTION CAP: STAINLESS STEEL
 - PICK AND PLACE CAP: LCP UL94, V-0 COLOR BLACK
 - BASE METAL: HIGH CONDUCTIVE COPPER ALLOY
 - PLATING ON CONTACTS: 0.75 MICRON MIN GOLD OVER 1.27 MICRON MIN NICKEL
 - PLATING ON BODY: 3.18 MICRON MIN SILVER OVER 1.27 MICRON MIN NICKEL
 - MATES WITH MOLEX 11MM MALE PIN:
 - 11.0MM SMT MALE PIN DRAWING 213901-0000-SD, MIN. MATING DISTANCE 6.5MM
 - 11.0MM PRESS FIT MALE PIN DRAWING 213900-0000-SD, MIN. MATING DISTANCE 6.85MM
 - 11.0MM SCREW MOUNT MALE PIN DRAWING 213902-0000-SD MIN. MATING DISTANCE 9.85MM
 - PRODUCT SPECIFICATION: 21328800001-PS
 - APPLICATION SPECIFICATION: 2138800001-AS
SEE APPLICATION SPEC FOR SOLDERING INFORMATION.
 - PACKAGING SPECIFICATION: 2139520001-PK(TRAY)
 - SILVER COMPONENTS WILL BE SUPPLIED TARNISH FREE BUT MAY TARNISH OVER TIME.
 - PICK AND PLACE CAP TO BE REMOVED AFTER SOLDERING. CAP TO BE PUSHED OUT OF BOTTOM FROM THE TOP.

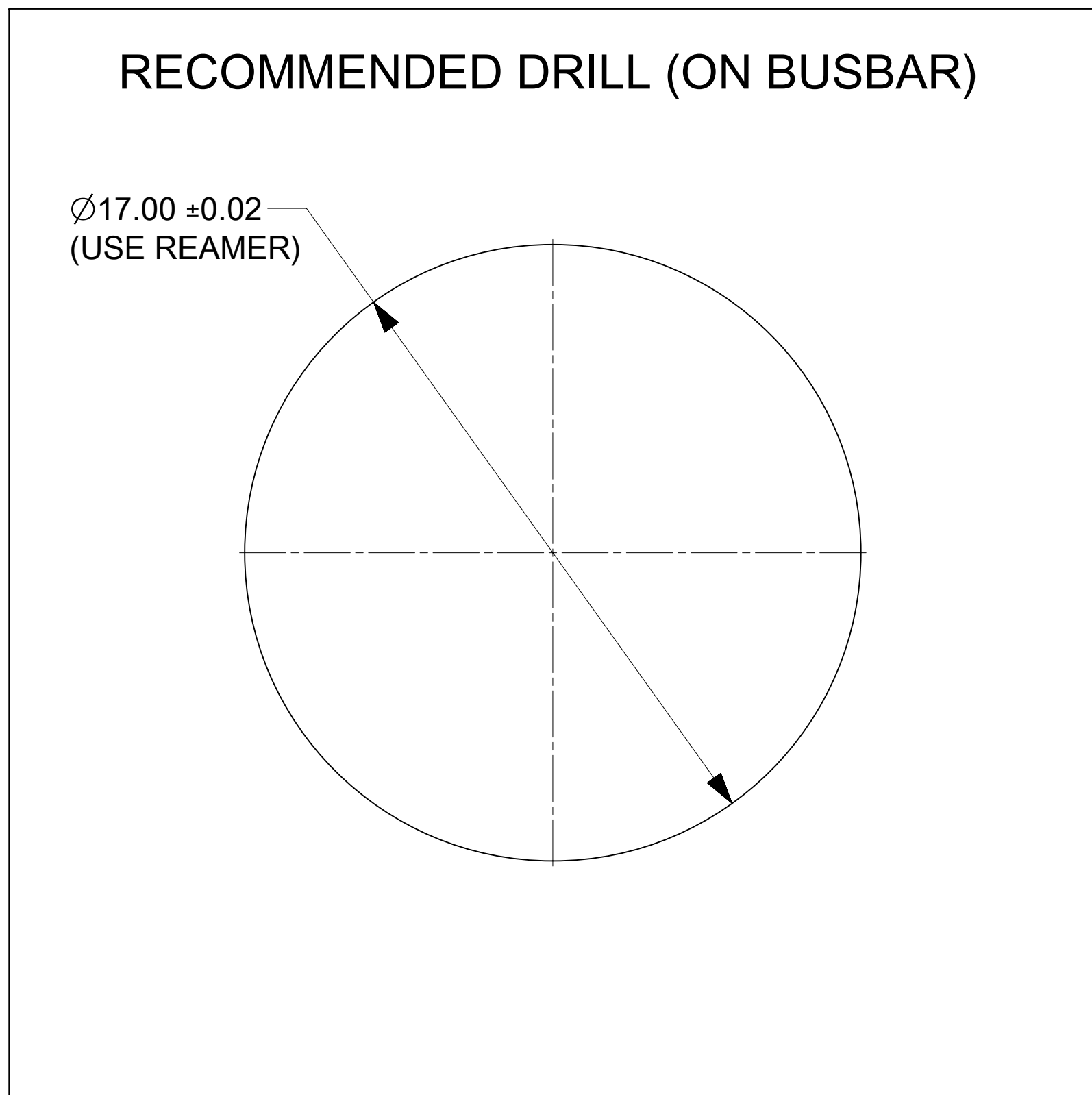
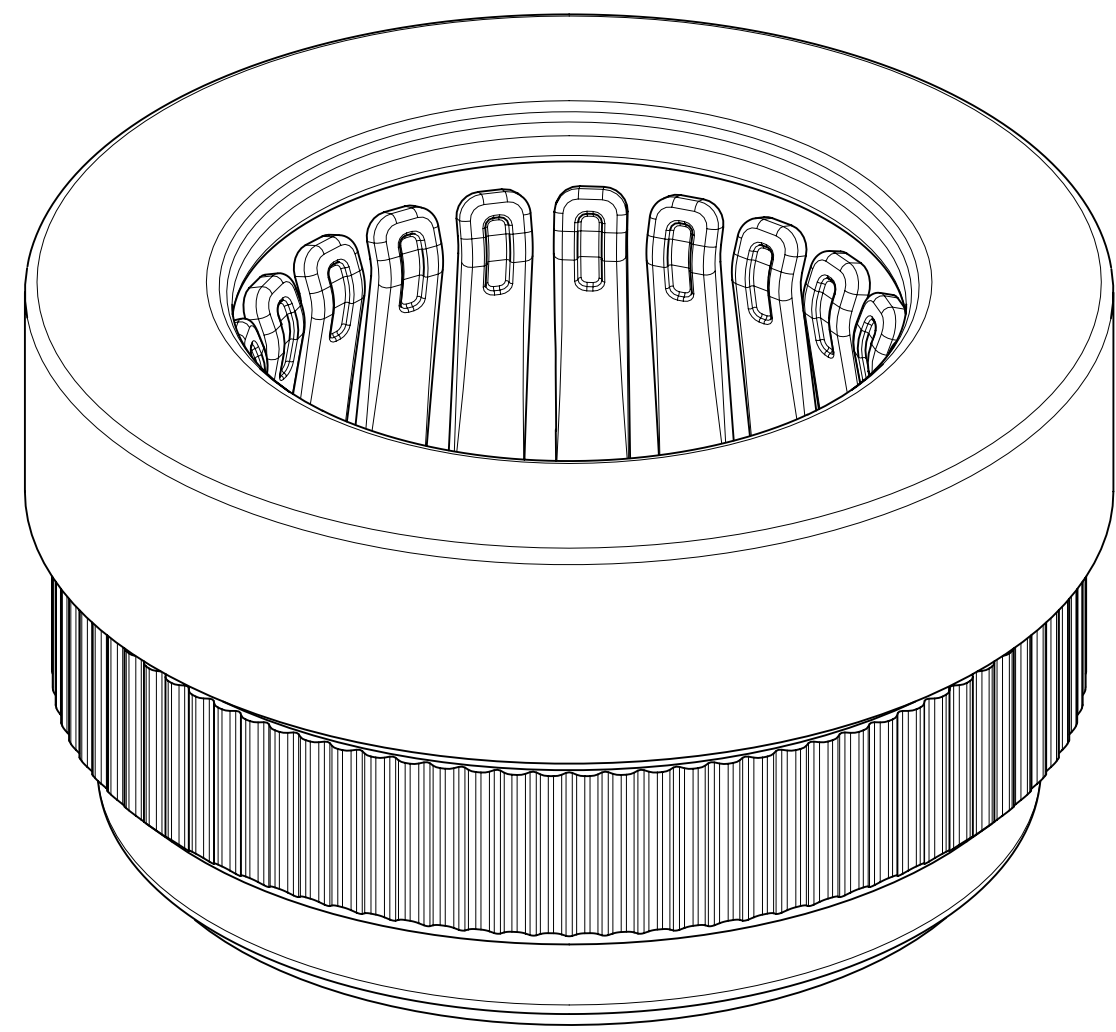
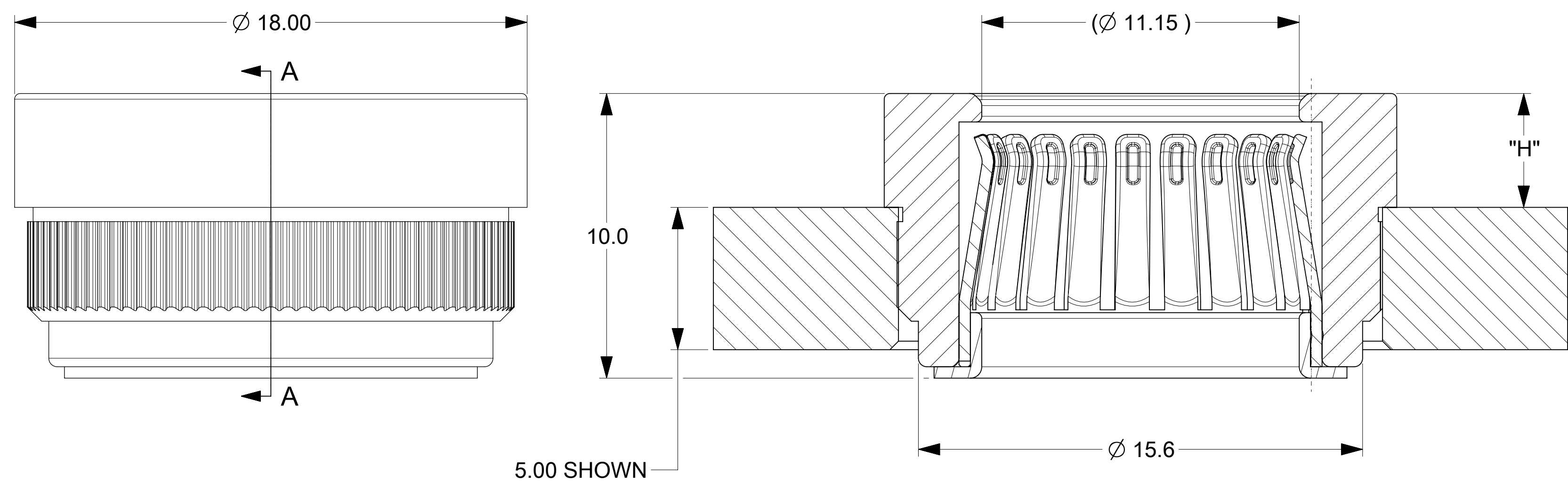

SECTION A-A

(PICK AND PLACE CAP NOT SHOWN)

THIS DRAWING CONTAINS INFORMATION THAT IS PROPRIETARY TO MOLEX ELECTRONIC TECHNOLOGIES, LLC AND SHOULD NOT BE USED WITHOUT WRITTEN PERMISSION											
DIMENSION UNITS		SCALE		CURRENT REV DESC: UPDATED THE TITLE BLOCK						molex	
mm		NTS									
GENERAL TOLERANCES (UNLESS SPECIFIED)				EC NO: 747243		11.0MM CENTRALITY TOP ENTRY PRESS-FIT STANDARD SOCKET IN TRAY					
ANGULAR TOL ± 0.5°				DRWN: SOURAJ 2023/03/01		PRODUCT CUSTOMER DRAWING					
4 PLACES ±				CHK'D: SCS02 2023/04/25		DOCUMENT NUMBER					
3 PLACES ±				APPR: HTHYAGARAJ 2023/04/26		DOC TYPE					
2 PLACES ± 0.15				INITIAL REVISION:		DOC PART					
1 PLACE ± 0.25				DRWN: RLOW 2020/08/17		REVISION					
0 PLACES ±				APPR: JJONIAK 2022/08/16		2137800001-SD					
DRAFT WHERE APPLICABLE MUST REMAIN WITHIN DIMENSIONS				THIRD ANGLE PROJECTION		DRAWING		MATERIAL NUMBER		CUSTOMER	
				D-SIZE		SERIES		SEE CHART		GENERAL MARKET	
						213780				SHEET NUMBER	
										1 OF 1	

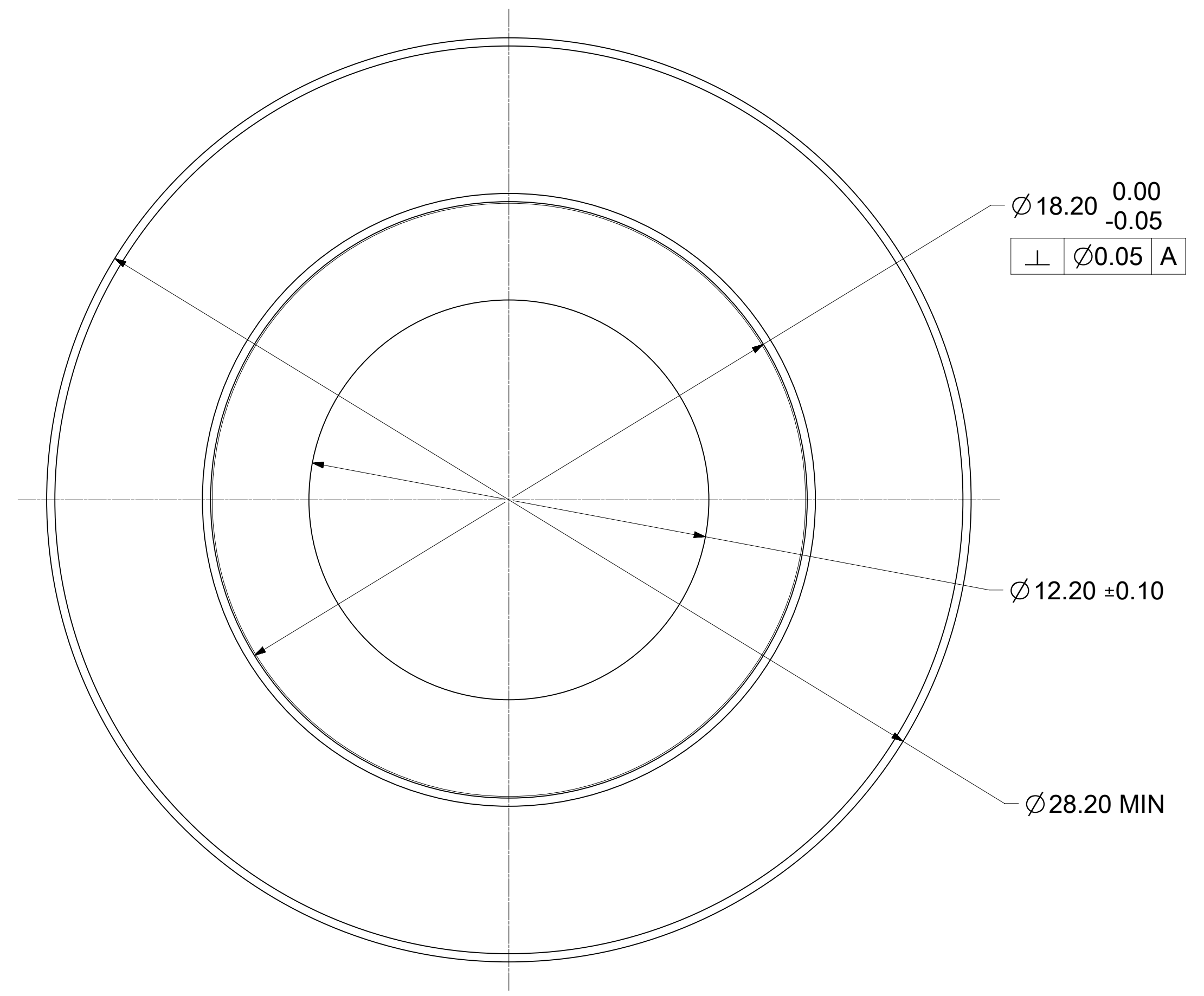
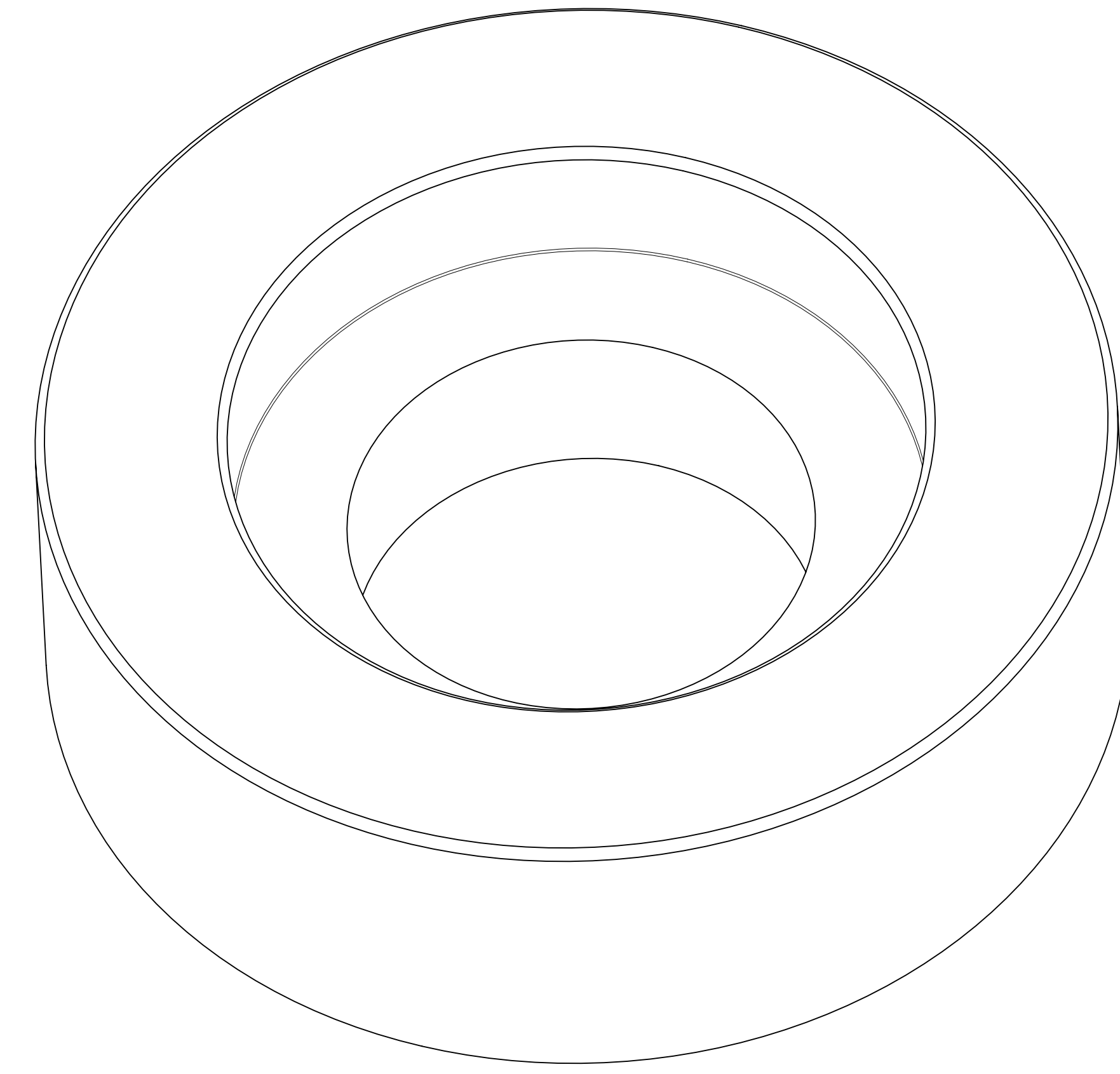
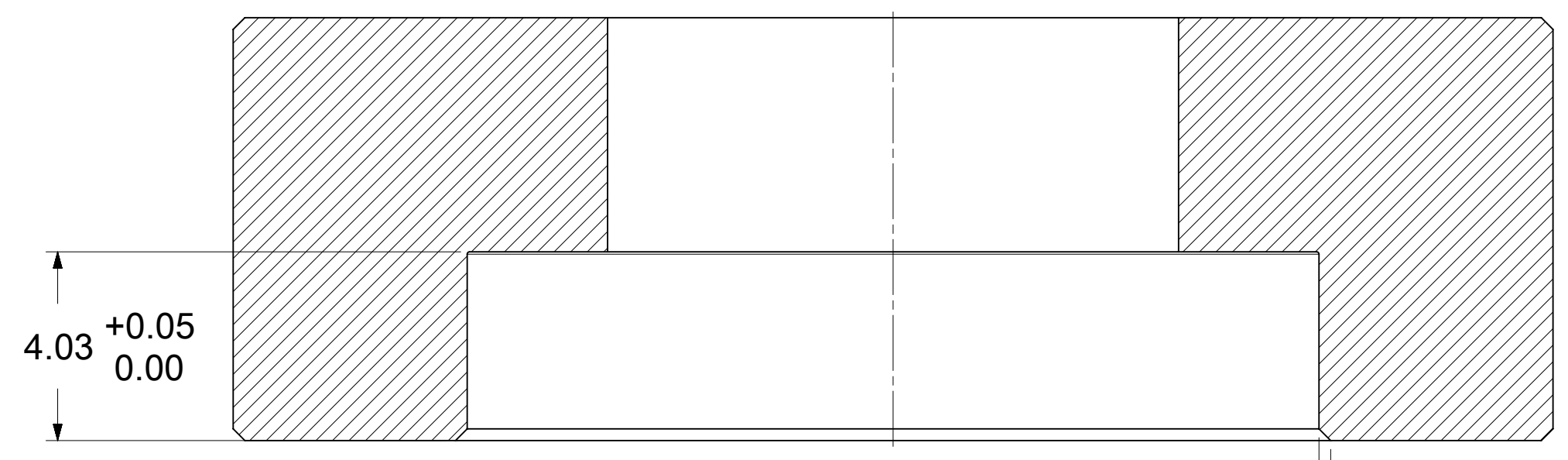
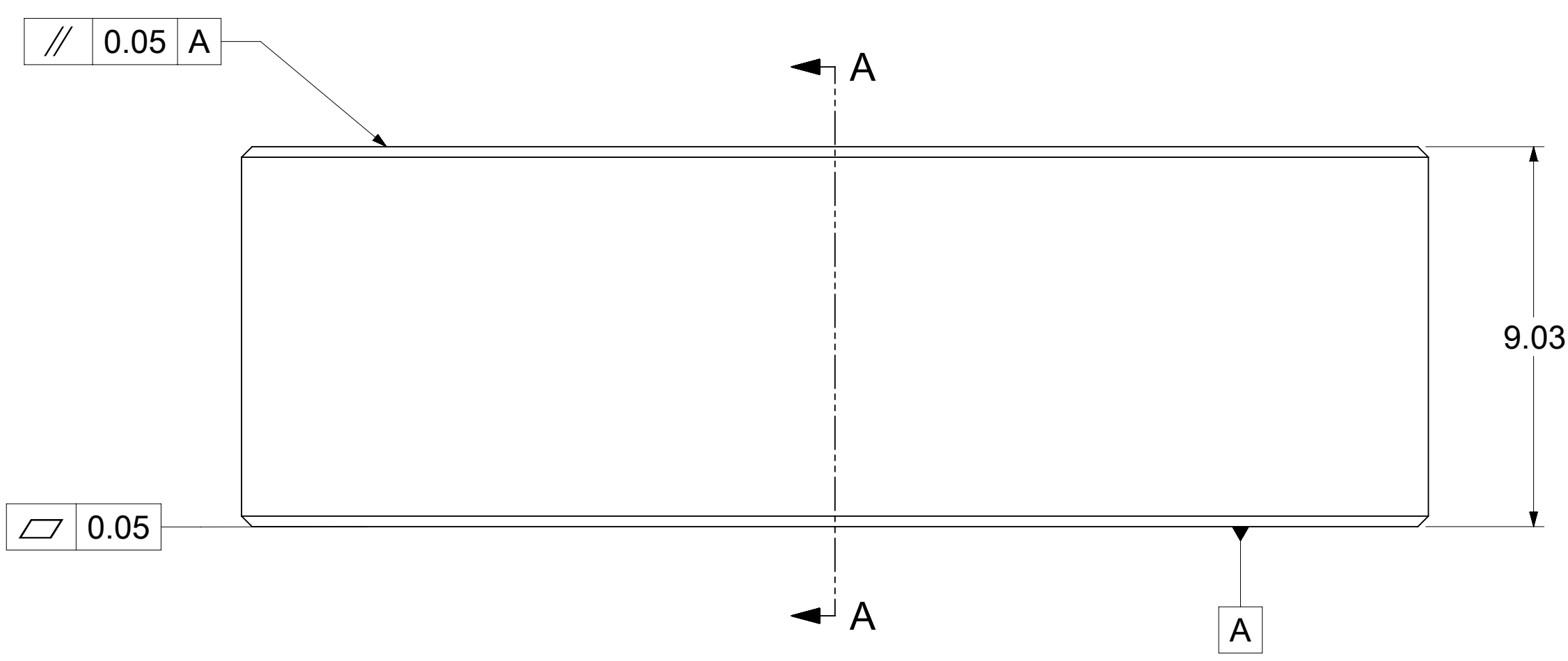

- NOTES:**
1. MATERIAL: STAINLESS STEEL
 2. BREAK ALL SHARP CORNERS AND EDGES

THIS DRAWING CONTAINS INFORMATION THAT IS PROPRIETARY TO MOLEX ELECTRONIC TECHNOLOGIES, LLC AND SHOULD NOT BE USED WITHOUT WRITTEN PERMISSION									
DIMENSION UNITS		SCALE		CURRENT REV DESC: INITIAL RELEASE					
mm		8:1		<div style="text-align: center;">molex</div> CENTRALITY APPLICATION TOOLING FOR 11.0MM STANDARD SOCKET PRODUCT CUSTOMER DRAWING					
GENERAL TOLERANCES (UNLESS SPECIFIED)									
ANGULAR TOL		± 0.5°							
4 PLACES		±							
3 PLACES		±							
2 PLACES		± 0.05		EC NO: 771891		2023/04/04		DOCUMENT NUMBER	
1 PLACE		± 0.1		DRWN: SOURAJ		2023/12/15		DOC TYPE	
0 PLACES		±		APPR: KPRASAD		2023/12/19		DOC PART	
DRAFT WHERE APPLICABLE MUST REMAIN WITHIN DIMENSIONS				THIRD ANGLE PROJECTION		DRAWING		REVISION	
				D-SIZE		SERIES		MATERIAL NUMBER	
				219259		2192590101		CUSTOMER	
				GENERAL MARKET		SHEET NUMBER			
				1 OF 1					

DOCUMENT STATUS	P1	RELEASE DATE	2023/12/19	10:05:22
-----------------	----	--------------	------------	----------