

General Description

LM1117X is a series of low dropout three-terminal regulators with a dropout of 1.3V at 1A load current.

LM1117X features a very low standby current 2mA compared to 5mA of competitor. Other than a fixed version, $V_{out} = 1.2V, 1.5V, 1.8V, 2.5V, 2.85V, 3.3V,$ and 5V, LM1117X has an adjustable version which can provide an output voltage from 1.25 to 12V with only two external resistors.

LM1117X offers thermal shut down function, to assure the stability of chip and power system. And it uses trimming technique to guarantee output voltage accuracy within 2% Other output voltage accuracy can be customized on demand, such as 1%.

LM1117X is available in SOT-223, TO-252 and SOT89 power package.

Features

- Output current is 1A
- Range of operation input voltage: 15V
- Line regulation: 0.03%/V (typ.)
- Standby current: 2mA (typ.)
- Load regulation: 0.2%/A (typ.)
- Environment Temperature: $-40^{\circ}C \sim 85^{\circ}C$

Applications

- Power Management for Computer Mother Board, Graphic Card
- LCD Monitor and LCD TV
- DVD Decode Board
- ADSL Modem
- Post Regulators for Switching Supplies

Table1: LM1117S series (SOT223 PKG)

PIN NO.	PIN NAME	FUNCTION
1	VSS/ADJ	VSS/ADJ pin
2	VOUT	Output voltage pin
3	VIN	Input voltage pin
4	VOUT	Output voltage pin

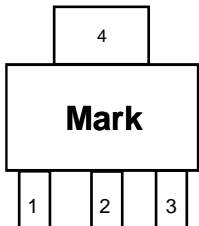

Table2: LM1117RS series (TO252 PKG)

PIN NO.	PIN NAME	FUNCTION
1	VSS/ADJ	VSS/ADJ pin
2	VOUT	Output voltage pin
3	VIN	Input voltage pin

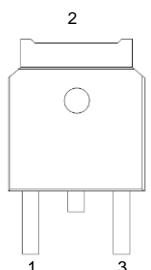
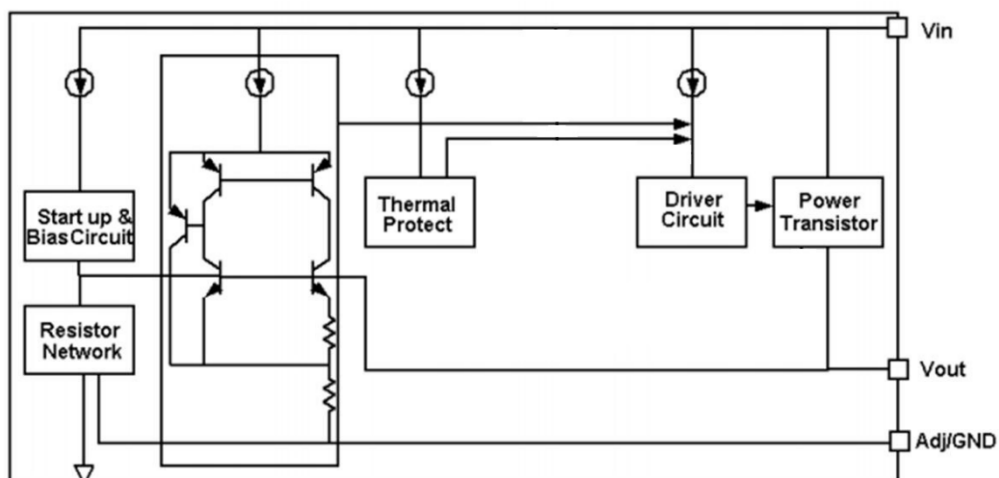

Table3: LM1117F series (SOT89 PKG)

PIN NO.	PIN NAME	FUNCTION
1	VSS/ADJ	VSS/ADJ pin
2	VOUT	Output voltage pin
3	VIN	Input voltage pin

Block Diagram



Selection Table

Part No.	Part No.	Output Voltage	Package
LM1117X-XXX	XX=12	1.2V	SOT-223 TO-252 SOT-89
	XX=15	1.5V	
	XX=18	1.8V	
	XXX=285	2.85V	
	XX=25	2.5V	
	XX=33	3.3V	
	XX=50	5.0V	
	XX=ADJ	ADJ	

Ordering Information

Part No.	Package Type	Packing type
LM1117F	SOT89	1000 Tape&Reel
LM1117S	SOT223	2500 Tape&Reel
LM1117RS	TO252	2500 Tape&Reel

Absolute Maximum Ratings

Max Input Voltage 18V
 Max Operating Junction Temperature(Tj) 150°C
 Storage Temperature(Ts)..... -55°C~150°C
 Lead Temperature & Time..... 260°C 10S
 Caution: Exceed these limits to damage to the device. Exposure to absolute maximum rating conditions may affect device reliability.

Electrical Characteristics

T_A=25°C , unless otherwise noted.

Symbol	Parameter	Conditions	Min	Typ	Max	Unit
V _{in}	Input voltage		--	15	18	V
V _{ref}	Reference voltage	LM1117-Adj 10mA ≤ I _{out} ≤ 1A , V _{in} =2.55V	1.225	1.25	1.275	V
V _{out}	Output voltage	LM1117-1.2V 0 ≤ I _{out} ≤ 1A , V _{in} =2.5V	1.176	1.2	1.224	V
		LM1117-1.5V 0 ≤ I _{out} ≤ 1A , V _{in} =2.8V	1.47	1.5	1.53	V
		LM1117-1.8V 0 ≤ I _{out} ≤ 1A , V _{in} =3.1V	1.764	1.8	1.836	V
		LM1117-2.5V 0 ≤ I _{out} ≤ 1A , V _{in} =3.8V	2.45	2.5	2.55	V
		LM1117-2.85V 0 ≤ I _{out} ≤ 1A , V _{in} =4.15V	2.793	2.85	2.907	V
		LM1117-3.3V 0 ≤ I _{out} ≤ 1A , V _{in} =4.6V	3.234	3.3	3.366	V
		LM1117-5.0V 0 ≤ I _{out} ≤ 1A , V _{in} =6.3V	4.9	5	5.1	V
ΔV _{out}	Line regulation	LM1117-1.2V I _{out} =10mA, 2.5V ≤ V _{in} ≤ 10V		4	19	mV
		LM1117-1.5V I _{out} =10mA, 2.8V ≤ V _{in} ≤ 10V		5	26	mV
		LM1117-ADJ I _{out} =10mA, 2.55V ≤ V _{in} ≤ 12V		5	24	mV
		LM1117-1.8V I _{out} =10mA, 3.1V ≤ V _{in} ≤ 12V		5	32	mV
		LM1117-2.5V I _{out} =10mA, 3.8V ≤ V _{in} ≤ 12V		8	41	mV
		LM1117-2.85V I _{out} =10mA, 4.15V ≤ V _{in} ≤ 12V		8	46	mV
		LM1117-3.3V I _{out} =10mA, 4.6V ≤ V _{in} ≤ 12V		9	49	mV
		LM1117-5.0V I _{out} =10mA, 6.3V ≤ V _{in} ≤ 12V		10	56	mV

ΔV_{out}	Load regulation	LM1117-1.2V $V_{in} = 2.5V, 10mA \leq I_{out} \leq 1A$	10	40	mV
		LM1117-1.5V $V_{in} = 2.8V, 10mA \leq I_{out} \leq 1A$	10	40	mV
		LM1117-ADJ $V_{in} = 2.55V, 10mA \leq I_{out} \leq 1A$	10	40	mV
		LM1117-1.8V $V_{in} = 3.1V, 10mA \leq I_{out} \leq 1A$	10	40	mV
		LM1117-2.5V $V_{in} = 2.8V, 10mA \leq I_{out} \leq 1A$	10	40	mV
		LM1117-2.85V $V_{in} = 4.15V, 10mA \leq I_{out} \leq 1A$	10	40	mV
		LM1117-3.3V $V_{in} = 4.6V, 10mA \leq I_{out} \leq 1A$	10	40	mV
		LM1117-5.0V $V_{in} = 6.3V, 10mA \leq I_{out} \leq 1A$	10	40	mV
V_{drop}	Dropout voltage	$I_{out} = 100mA$	1.15	1.3	V
		$I_{out} = 1A$	1.3	1.5	V
I_{min}	Minimum load current	LM1117-ADJ	2	10	mA
I_q	Quiescent Current	LM1117-1.2V, $V_{in} = 10V$	2	5	mA
		LM1117-1.5V, $V_{in} = 10V$	2	5	mA
		LM1117-1.8V, $V_{in} = 12V$	2	5	mA
		LM1117-2.5V, $V_{in} = 12V$	2	5	mA
		LM1117-2.85V, $V_{in} = 12V$	2	5	mA
		LM1117-3.3V, $V_{in} = 12V$	2	5	mA
		LM1117-5.0V, $V_{in} = 12V$	2	5	mA
I_{adj}	Adjust pin current	LM1117-ADJ $V_{in} = 5V, 10mA \leq I_{out} \leq 1A$	55	120	μA
I_{change}	I_{adj} change	LM1117-ADJ $V_{in} = 5V, 10mA \leq I_{out} \leq 1A$	0.2	10	μA

ΔV_{out}	Temperature coefficient	$V_{in} = 4.5V, I_{out} = 10mA$ $V_{OUT} = 3.3V, 20^{\circ}C \leq T_a \leq 120^{\circ}C$	30		mV
θ_{JC}	Thermal resistance	SOT-223	20		$^{\circ}C/W$
		TO-252	10		

Note1: All test are conducted under ambient temperature 25°C and within a short period of time 20ms

Note2: Load current smaller than minimum load current of LM1117-ADJ will lead to unstable or oscillation output.

Detailed Description

LM1117X is a series of low dropout voltage, three terminal regulators. Its application circuit is very simple: the fixed version only needs two capacitors and the adjustable version only needs two resistors and two capacitors to work. It is composed of some modules including start-up circuit, bias circuit, bandgap, thermal shutdown, power transistors and its driver circuit and so on.

The thermal shut down modules can assure chip and its application system working safety when the temperature is larger than 170°C.

The bandgap module provides stable reference voltage, whose temperature coefficient is compensated by careful design considerations. The temperature coefficient is under 100 ppm/°C. And the accuracy of output voltage is guaranteed by trimming technique.

Typical Application

LM1117X has an adjustable version and six fixed versions (1.2V, 1.5V, 1.8V, 2.5V, 2.85V, 3.3V and 5V)

Fixed Output Voltage Version

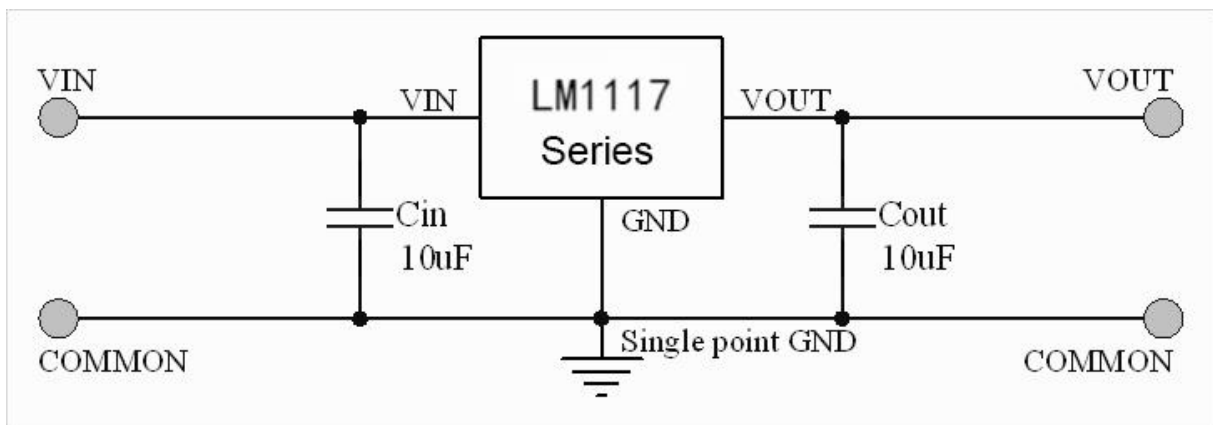

Application circuit of LM1117X fixed version

- (1) Recommend using 10uF tan capacitor as bypass capacitor (C1) for all application circuit.
- (2) Recommend using 10uF tan capacitor to assure circuit stability.

Adjustable Output Voltage Version

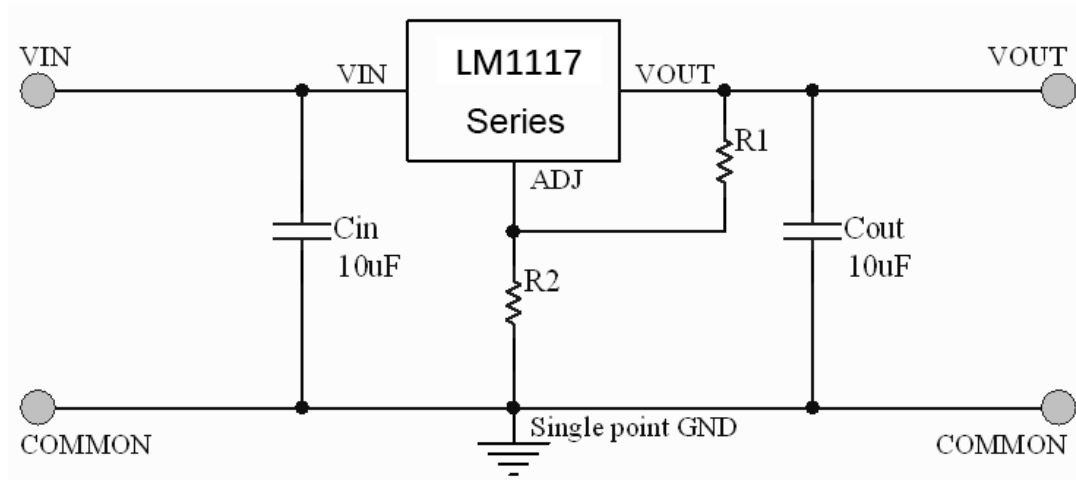

Application Circuit of LM1117-ADJ

The output voltage of adjustable version follows the equation: $V_{out} = 1.25 \times (1 + R_2/R_1) + I_{Adj} \times R_2$. We can ignore I_{Adj} because I_{Adj} (about 50µA) is much less than the current of R_1 (about 2~10mA).

1) To meet the minimum load current (>10mA) requirement, R_1 is recommended to be 125ohm or lower. As LM1117-ADJ can keep itself stable at load current about 2mA, R_1 is not allowed to be higher than 625ohm.

2) Using a bypass capacitor (C_{ADJ}) between the ADJ pin and ground can improve ripple rejection. This bypass capacitor prevents ripple from being amplified as the output voltage is increased. The impedance of C_{ADJ} should be less than R_1 to prevent ripple from being amplified. As R_1 is normally in the range of 100Ω~500Ω, the value of C_{ADJ} should satisfy this equation: $1/(2\pi \times f_{ripple} \times C_{ADJ}) < R_1$.

Thermal Considerations

We have to take heat dissipation into great consideration when output current or differential voltage of input and output voltage is large. Because in such cases, the power dissipation consumed by LM1117 is very large. LM1117 series uses SOT-223 package type and its thermal resistance is about 20°C/W. And the copper area of application board can affect the total thermal resistance. If copper area is 5cm*5cm (two sides), the resistance is about 30°C/W. So the total thermal resistance is about 20°C/W + 30°C/W. We can decrease total thermal resistance by increasing copper area in application board.

When there is no good heat dissipation copper are in PCB, the total thermal resistance will be as high as 120°C/W, then the power dissipation of LM1117 could allow on itself is less than 1W. And furthermore, LM1117 will work at junction temperature higher than 125°C under such condition and no lifetime is guaranteed.

Typical Performance Characteristics

$T_A=25^{\circ}\text{C}$, unless otherwise noted

Output Voltage vs. Input Voltage (VOUT=3.3V)

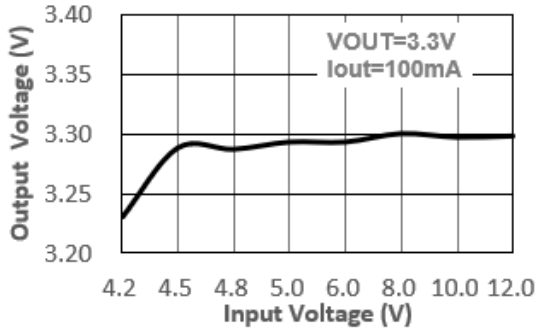

Output Voltage vs. Input Voltage (VOUT=1.8V)

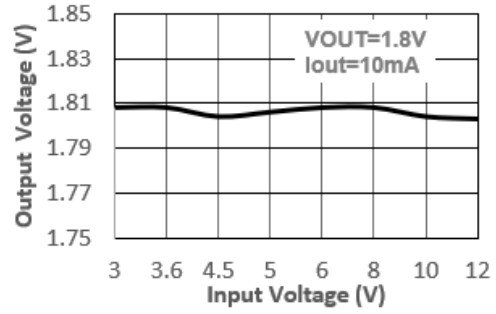

Output Voltage vs. Output Current (VOUT=3.3V)

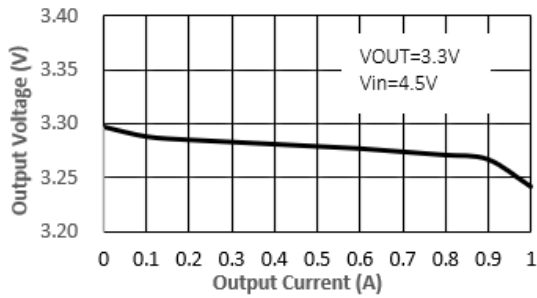

Output Voltage vs. Output Current (VOUT=1.8V)

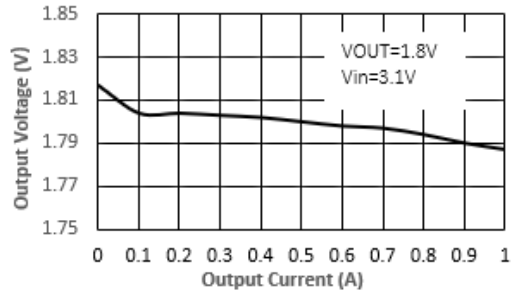

Line Regulation vs. Junction Temperature

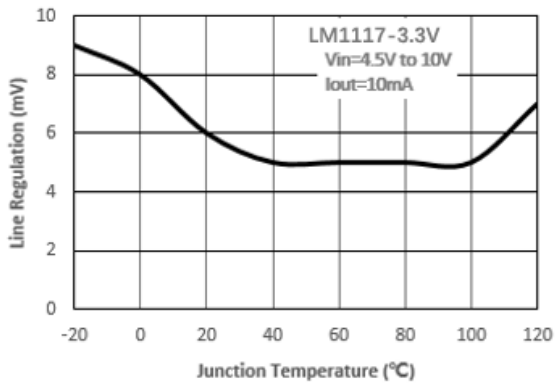

Load Regulation vs. Junction Temperature

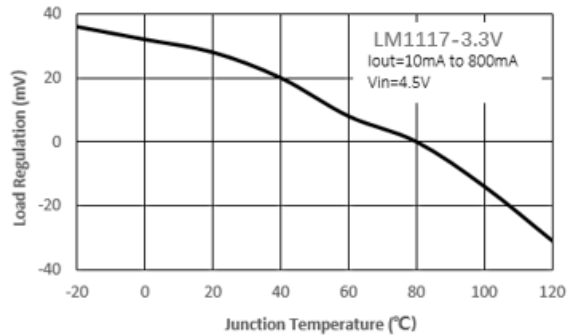

Reference Voltage vs. Junction Temperature

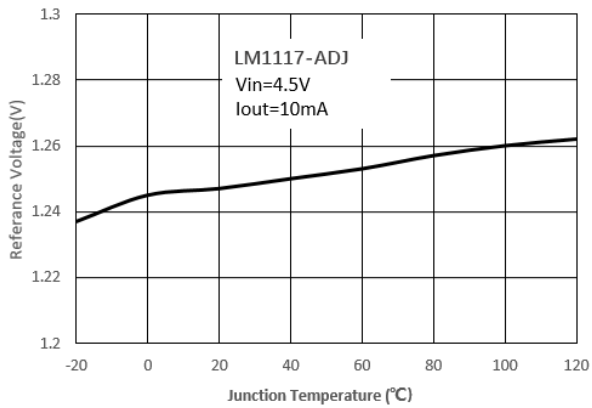

Output Voltage vs. Junction Temperature

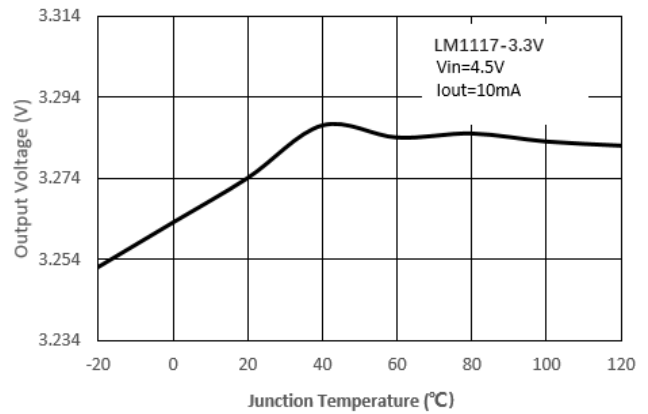

Minimum Load Current vs. Junction Temperature

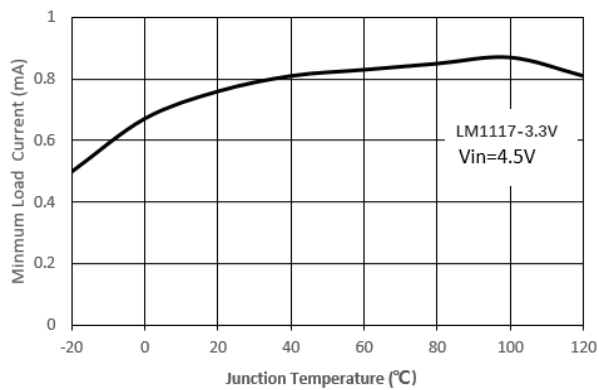

Adjust Pin Current vs. Junction Temperature

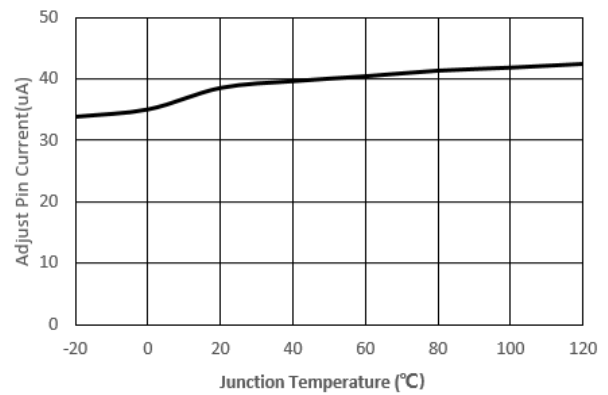

PSRR vs. Frequency

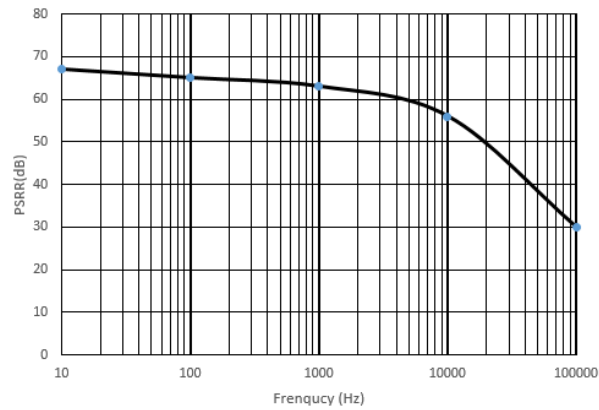

Dropout Voltage vs. Output Current

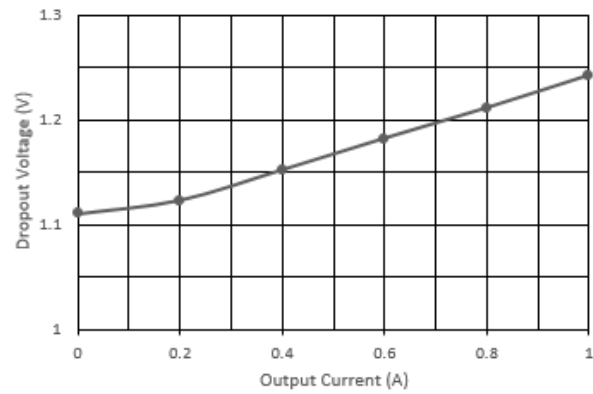

Line Transient Response

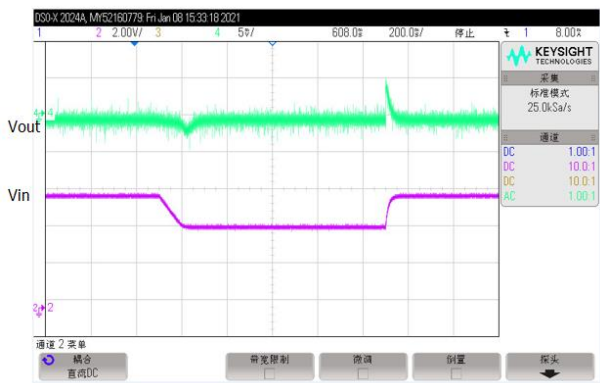

Load Transient Response

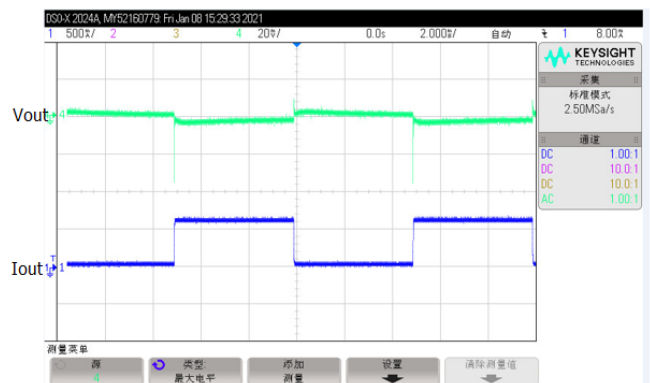

SOT-223 PACKAGE MECHANICAL DATA

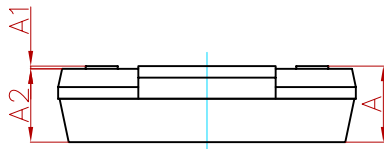
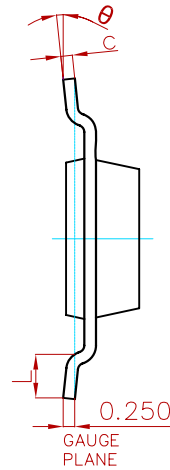
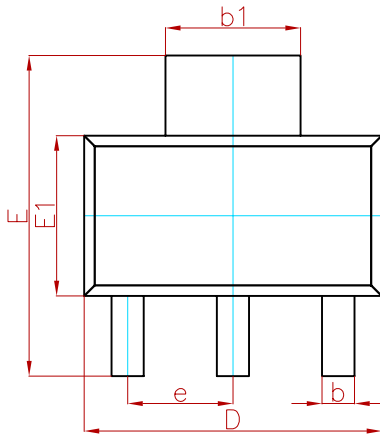

Symbol	Dimensions In Millimeters		Dimensions In Inches	
	Min.	Max.	Min.	Max.
A	—	1.800	—	0.071
A1	0.020	0.100	0.001	0.004
A2	1.500	1.700	0.059	0.067
b	0.660	0.840	0.026	0.033
b1	2.900	3.100	0.114	0.122
c	0.230	0.350	0.009	0.014
D	6.300	6.700	0.248	0.264
E	6.700	7.300	0.264	0.287
E1	3.300	3.700	0.130	0.146
e	2.300(BSC)		0.091(BSC)	
L	0.750	—	0.030	—
θ	0°	10°	0°	10°

Suggested Pad Layout

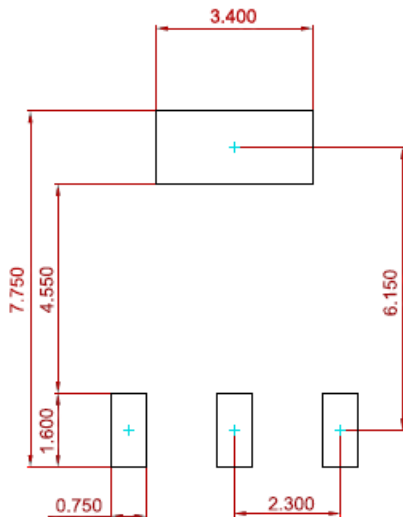

Note:

1. Controlling dimension: in millimeters.
2. General tolerance: ± 0.050 mm.
3. The pad layout is for reference purposes only.

TO-252 PACKAGE MECHANICAL DATA

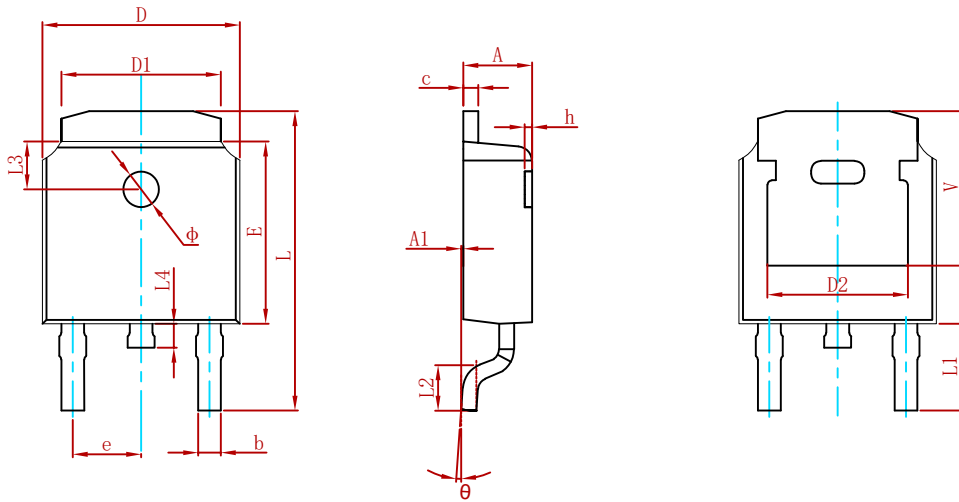

Symbol	Dimensions In Millimeters		Dimensions In Inches	
	Min.	Max.	Min.	Max.
A	2.200	2.400	0.087	0.094
A1	0.000	0.127	0.000	0.005
b	0.635	0.770	0.025	0.030
c	0.460	0.580	0.018	0.023
D	6.500	6.700	0.256	0.264
D1	5.100	5.460	0.201	0.215
D2	4.830 REF.		0.190 REF.	
E	6.000	6.200	0.236	0.244
e	2.186	2.386	0.086	0.094
L	9.712	10.312	0.382	0.406
L1	2.900 REF.		0.114 REF.	
L2	1.400	1.700	0.055	0.067
L3	1.600 REF.		0.063 REF.	
L4	0.600	1.000	0.024	0.039
Φ	1.100	1.300	0.043	0.051
θ	0°	8°	0°	8°
h	0.000	0.300	0.000	0.012
V	5.250 REF.		0.207 REF.	

Suggested Pad Layout

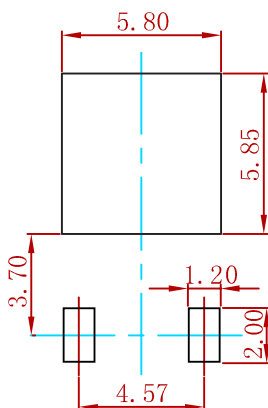

Note:

1. Controlling dimension: in millimeters.
2. General tolerance: $\pm 0.05\text{mm}$.
3. The pad layout is for reference purposes only.

SOT-89 PACKAGE MECHANICAL DATA

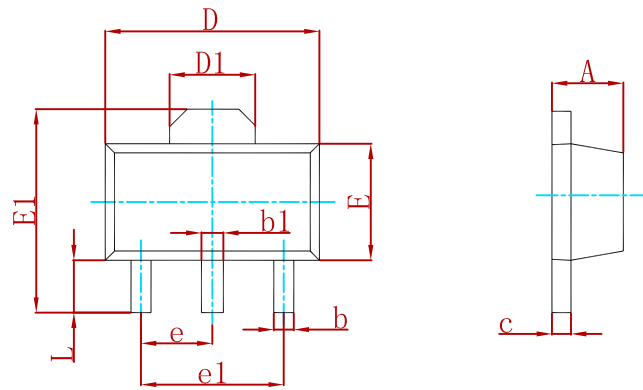

Symbol	Dimensions In Millimeters		Dimensions In Inches	
	Min	Max	Min	Max
A	1.400	1.600	0.055	0.063
b	0.320	0.520	0.013	0.020
b1	0.400	0.580	0.016	0.023
c	0.350	0.440	0.014	0.017
D	4.400	4.600	0.173	0.181
D1	1.550 REF.		0.061 REF.	
E	2.300	2.600	0.091	0.102
E1	3.940	4.250	0.155	0.167
e	1.500 TYP.		0.060 TYP.	
e1	3.000 TYP.		0.118 TYP.	
L	0.900	1.200	0.035	0.047

Suggested Pad Layout

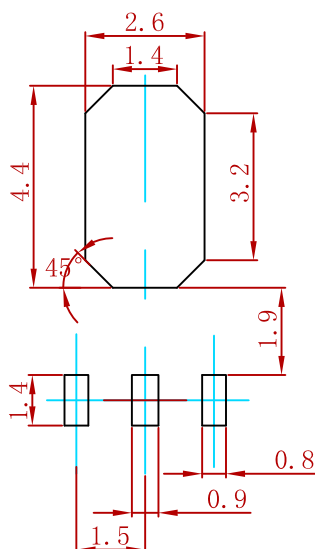

Note:

1. Controlling dimension: in millimeters.
2. General tolerance: $\pm 0.05\text{mm}$.
3. The pad layout is for reference purposes only.