

CAD FILE:

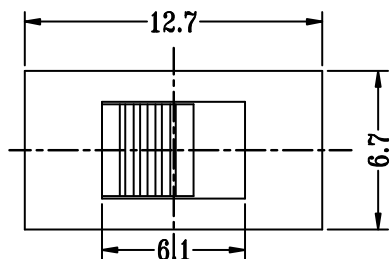

电气性能参数:

1. 额定负载: AC125V 2A
2. 接触电阻: 100毫欧以下
3. 绝缘电阻: 100兆欧以上
4. 耐压: AC 500V
5. 力度: 250 ± 100 gf
6. 寿命: 5000次
7. 手焊: 350 ± 10 度

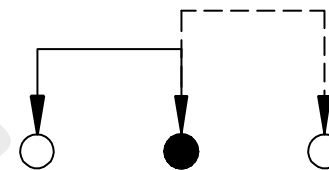

SCHEMATIC(NON-SHORTING)

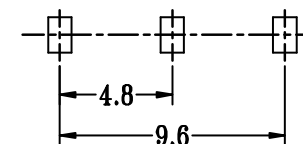
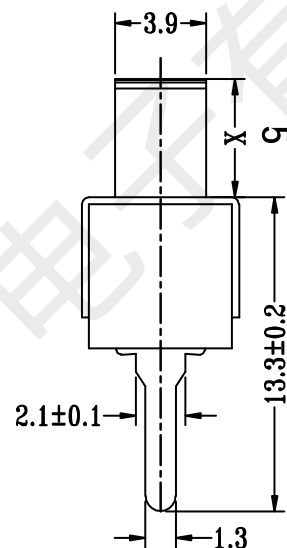
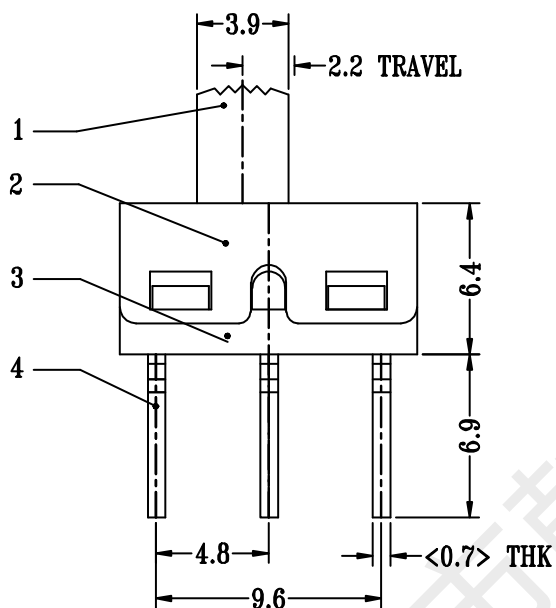

P.C.B LAYOUT
BOTTOM VIEW

NO.	PARTS	MATERIALS	Q'TY	FINISH	TOLERANCE					
8					UNLESS SPECIFIED					
7	STEEL BALL	STEEL	1	NATURAL	WITHIN 1.5mm : ± 0.1 mm	A				
6	SPRING	STEEL WIRE	1	NATURAL	OVER 1.5mm : ± 0.2 mm	ISSUE	DATE	初版		
5	CONTACT	COPPER STRIP	1	Ag PLATED	TITLE : VERTICAL SLIDE SWITCH		UNIT : mm	DRWG NO.: DR-SS12D10-00		
4	TERMINAL	COPPER STRIP	3	Ag PLATED	MODEL: SS-12D10L5		SCALE: 3 : 1	DWN.	黄彬	2020.9.16
3	CASE	NYLON	1	BLACK	 深圳市韩下电子有限公司			CHK'D	张伟	2020.9.16
2	COVER	SUS	1	NATURAL				APPD.	罗小春	2020.9.16
1	KNOB	NYLON	1	BLACK						