

# Instructions for 1397G1 Press-Fit Insertion Tool

The 1397G1 press-fit insertion tool is a cycle controlled tool designed to insert Anderson Power Products' 30 amp pin and socket contacts into a housing.

## OPERATION INSTRUCTIONS:

1. Insert crimped contact into the back end of the housing as shown in (Figure 1).
2. Cycle tool fully (empty) and allow handles to spring back to spring back to the fully open position (this insures that the tool is fully open upon insertion of housing and contact).
3. Install the contact and housing into top of tool by positioning the slots of the housing into the locator grooves and the axis of the contact into the clip fingers (Figure 2). Press the housing/contact down until it bottoms out in the tool (Figure 3). Insure that the spring loaded clip fingers are located between the conductor insulation and the contact barrel.
4. Cycle tool fully and release to allow the handles to spring back open to the fully open position.
5. Remove the completed assembly (contact / conductor / housing) from the tool by pulling it out of the locator grooves and spring loaded clip fingers. It is easiest to do this by placing the thumb underneath the housing near the locator grooves and the forefinger underneath the conductor that is sticking out of the clip fingers, then pulling up.  
**Warning! DO NOT cycle the tool while fingers are near moving parts.**

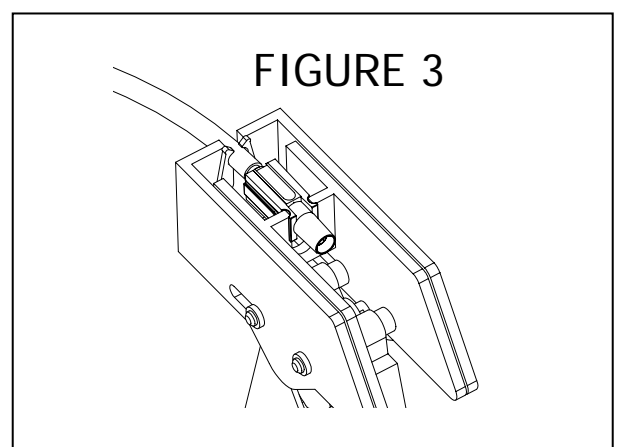
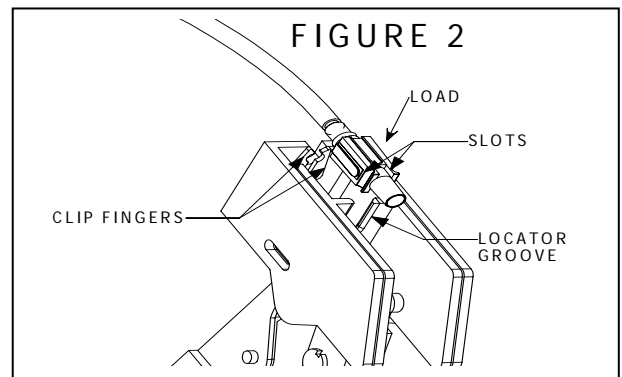
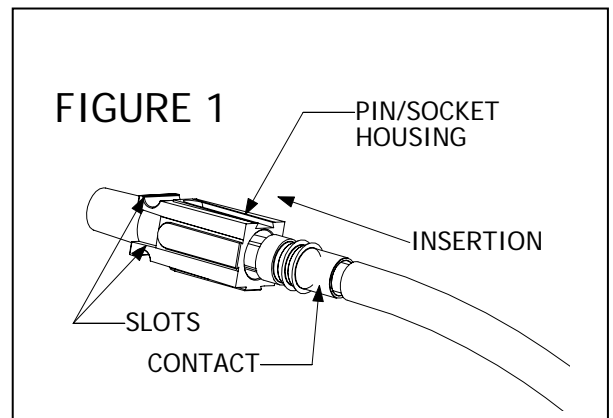

6. To verify good insertion of the crimped contact into the housing, the contact barrel should not be exposed more than .05" from the back face of the housing (Figure 4).

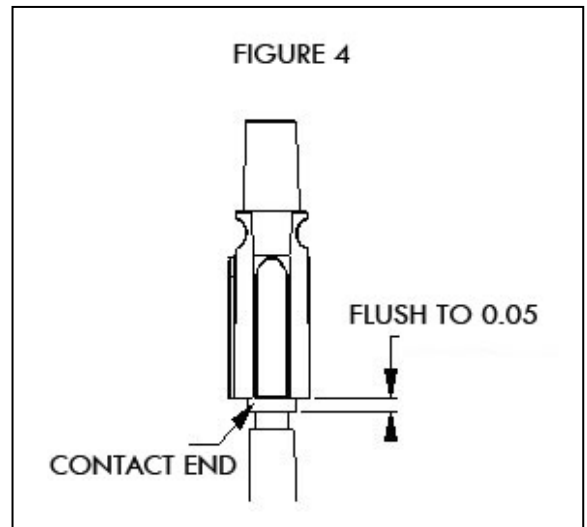

### MAINTENANCE SUGGESTIONS:

1. For Increased tool life, lubricate the pins and pin guide slots of the tool every 50 cycles (Figure 5).
2. To verify that the tool is cycling completely and is within calibration, see Step 6 of the Operation Instructions. If the given allowable distance (.050") is exceeded, the tool has exceeded its acceptable life.
3. Contact Anderson Power Products or your local Anderson distributor for any other questions regarding this tool.

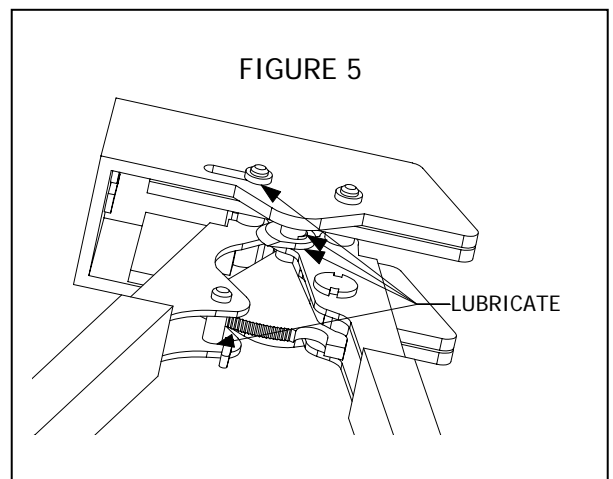

# Mouser Electronics

Authorized Distributor

Click to View Pricing, Inventory, Delivery & Lifecycle Information:

[Anderson Power Products:](#)

[1397G1](#)