

Product Area Male socket, front fastened, dip solder, M12 x 1, 12 pol
M12 connectors A-Coding serie 713/763

Pole 12
Article number 09 3491 550 12

illustration



scale drawing

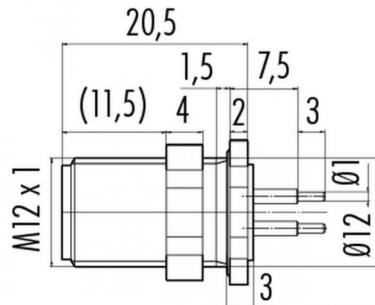

Contact Arrangement

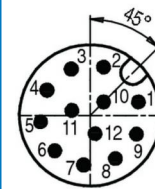

	X	Y
1	2,80	0,78
2	0,78	2,80
3	-1,09	2,69
4	-2,51	1,46
5	-2,88	-0,37
6	-2,05	-2,05
7	-0,37	-2,88
8	1,46	-2,51
9	2,69	-1,09
10	0,78	0,78
11	-1,06	0,29
12	0,29	-1,06

Installation instructions / Mounting cutout

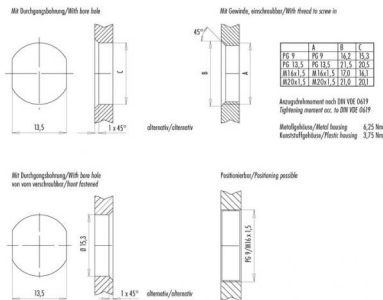

Technical data

Common values

Connector Design	Male socket
Connector locking system	Screw-locking
Termination	dip solder
Upper temperature	+85 °C
Lower temperature	-25 °C

Material

Material of contact	CuZn (brass)
Contact plating	Au (gold)
Material of contact body	PA
Material of housing	CUZn (brass nickel plated)

Electrical values

Rated voltage	30 V
Rated impulse voltage	500 V
Pollution degree	3
Overvoltage category	II
Material group	II
Rated current (40°C)	1 A
Volume resistivity	≤ 3 mΩ
Degree of protection	IP 68
Mechanical operation	>100 mating cycles

Cable data

Contacts 12: Male socket, front fastened, dip solder, M12 x 1, contact 10,5 mm