



佛山市国星光电股份有限公司
FOSHAN NATIONSTAR OPTOELECTRONICS CO., LTD

产品规格书 SPECIFICATION

顾客名称 Customer		产品名称 Product	Chip LED
顾客型号 Customer Type		产品型号 Type	NCD3220S1
顾客部品号 Customer No.		版本号 Version NO	A 版



地址: 广东省佛山市禅城区华宝南路 18 号
 Add: NO.18 South Huabao Rd, Foshan, Guangdong, China
 电话 (Tel): 0757-82100219
 传真 (Fax): 0757-82100220
 邮编 (Zip): 528000
 邮箱 (Email): chipLED@nationstar.com
<http://www.nationstar.com>

研发中心 Research & Development Center		客户 (加盖公章) Customer (Stamp)	
制定 DRAW	审核 CHECK	批准 APPROVE	确认 CONFIRM
发放日期 (Release Date): 2022-12-05			



NCD3220S1

技术数据表 Technical Data Sheet

健康监测 (心率监测、脉搏血氧饱和度测定)

Health Monitoring (Heart Rate Monitoring, Pulse Oximetry)

- 特性:**
- 管芯材料: Silicon
 - 封装材料: 硅树脂
 - 焊接方法: 无铅回流焊
 - 功耗低, 可靠性好, 寿命长
 - 符合欧盟公布的 RoHS 指令要求
- Features:**
- Material: Silicon
 - Encapsulation: Silicon Resin
 - Soldering methods: Pb-Free reflow soldering
 - Low Power Dissipation, Good Reliability and Long Lifespan
 - Complied With RoHS Directive

光敏二极管
Photodiode



* 产品规格如因工艺改进而有所改变, 恕不另行通知。
* The specifications of the product may be modified for improvement without notice.

外形尺寸

Outline Dimension

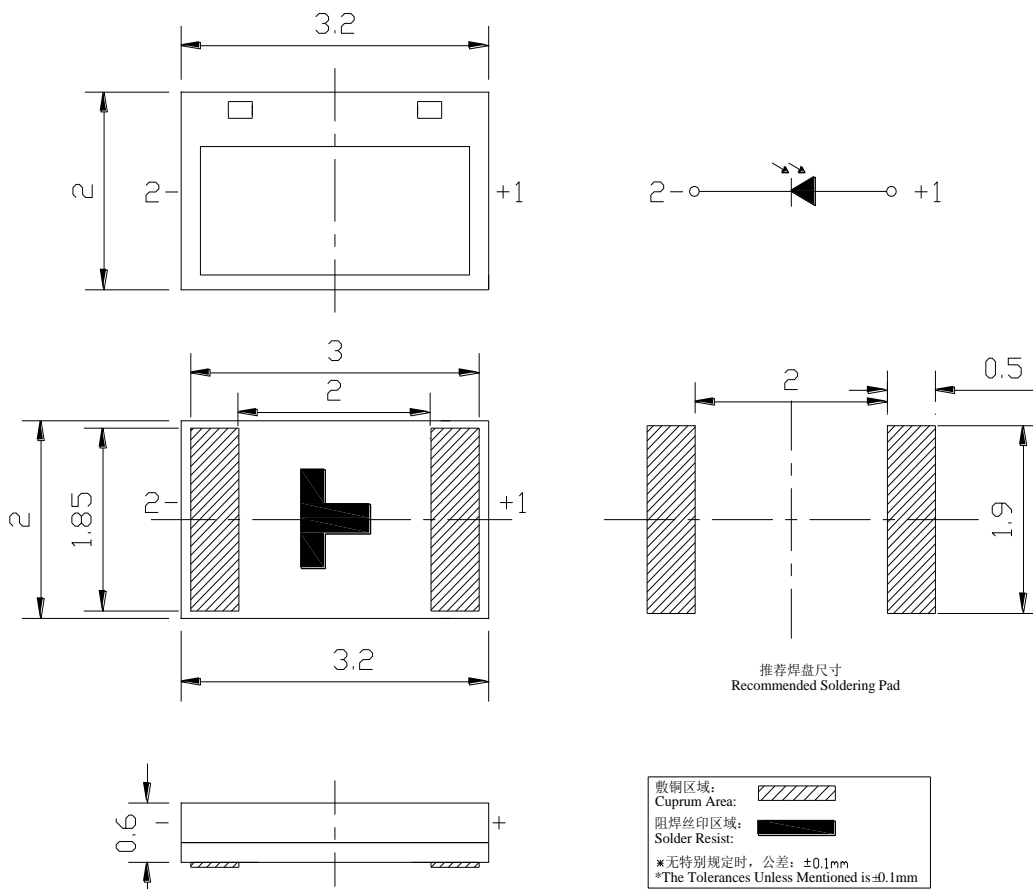

光电参数 (1)

Electro-Optical Characteristics(1)

极限参数 (温度=25°C)



Absolute Maximum Ratings (Temperature=25 °C)

参数名称 Parameter	符号 Symbol	数值 Rating	单位 Unit
反向电压 Reverse Voltage	V_R	5	V
工作温度 Operating Temperature	T_{OPR}	-40 ~ +85	°C
贮存温度 Storage Temperature	T_{stg}	-40 ~ +100	°C

* 注: 脉冲宽度 $\leq 0.1ms$, 占空比 $\leq 1/10$ * Note: Pulse Width $\leq 0.1ms$, Duty $\leq 1/10$

光电参数 (温度=25°C)



Electro-Optical Characteristics (Temperature=25 °C)

参数名称 Parameter	符号 Symbol	条件 Condition	最小值 Min.	典型值 Typ.	最大值 Max.	单位 Unit
光电流 Light Current	I_L	$V_R=0V$ $E_e=1mW/cm^2$ @940nm	11			μA
光电流 Light Current	I_L	$V_R=0V$ $E_e=1mW/cm^2$ @655nm	10			μA
光电流 Light Current	I_L	$V_R=0V$ $E_e=1mW/cm^2$ @525nm	8			μA
暗电流 Dark Current	I_D	$V_R=1V$ $E_e=0mW/cm^2$	-	-	20	nA
正向电压 Forward Voltage	V_F	$I_F=1mA$ $E_e=0mW/cm^2$	-	1	-	V
电容 Capacitance	C_0	$V_R=1V$ $E_e=0mW/cm^2$ $f=1MHz$	-	-	80	pF
		$V_R=0V$ $E_e=0mW/cm^2$ $f=1KHz\sim 1MHz$ $V_{ac}=0.1V$	-	-	200	pF
响应波段 Sensitivity Wavelength Range	λ	-	400	-	1100	nm
半灵敏度角度 Half angle	$\theta_{1/2}$	-	-	± 60	-	deg
感光区面积 Radiant sensitive area	-	-	2.9			mm^2

* 注: 以上参数仅供参考, 请以实物标签为准。我司给出的参数均由国星测试系统测得。

* Note: The parameters above are only for your reference. In case of any discrepancy, please adhere to the label of our actual products. All parameters are tested by the standard testing system of NationStar.

典型特性曲线

Typical Characteristics Curves

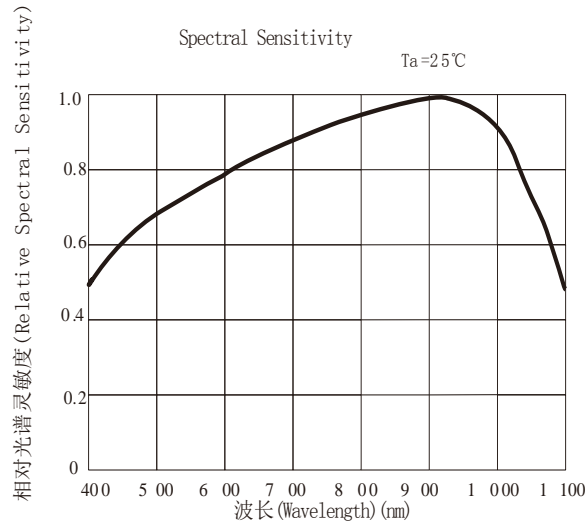



可靠性试验

Reliability Test Items And Conditions

实验项目 Test Items	参考标准 Reference	实验条件 Test Conditions	时间 Time	样品数 Quantity	判据 Criterion
耐焊接热 Resistance to Soldering Heat	GB/T 4937, II,2.2&2.3	Tsol*=260°C 10secs.	2次 2 times	22	0/22
湿热循环 Temperature And Humidity Cyclic	JEITA ED-4701 200 203	(-10~65)°C , (0~90)%RH 24hrs./1cycle	循环 10 次 10 cycles	22	0/22
高温贮存 High Temperature Storage	JEITA ED-4701 200 201	Ta=100°C	1000h	22	0/22
低温贮存 Low Temperature Storage	JEITA ED-4701 200 202	Ta=-40°C	1000h	22	0/22
冷热冲击 Thermal Shock	MIL-STD-202G	-40°C(15min)←→100°C(15min)	循环 200 次 200 cycles	22	0/22
常温寿命 Lifespan Test	JESD22-A108D	Ta=25°C VR= 5V	1000h	22	0/22

失效判断标准 Criteria For Judging Damage

测试项目 Test Items	符号 Symbol	测试条件 Test Conditions	判定标准 Criteria For Judging Damage
正向电压 Forward Voltage	V _F	I _F = I _{FT}	初始值±20% Initial Data ±20%
反向电流 Reverse Current	I _R	V _R = 5V	I _R ≤10μA
耐焊接热 Resistance to Soldering Heat	/	/	无死灯 No dead light

* 注: Tsol-锡液温度; I_{FT}: 典型电流
* Note: Tsol-Temperature of tin liquid; I_{FT}: Typical current.

包装 (1)

Packaging (1)

◇ 载带 Carrier Tape

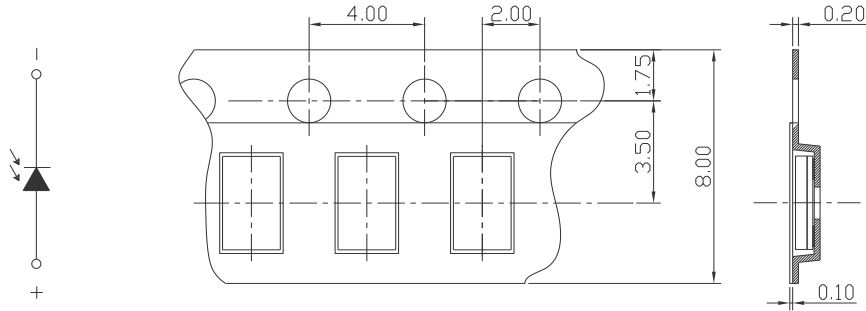

单位: mm, 未注公差: ±0.1 mm

All dimensions in mm, tolerances unless mentioned is ±0.1 mm.

◇ 编带细节 Details Of Carrier Tape

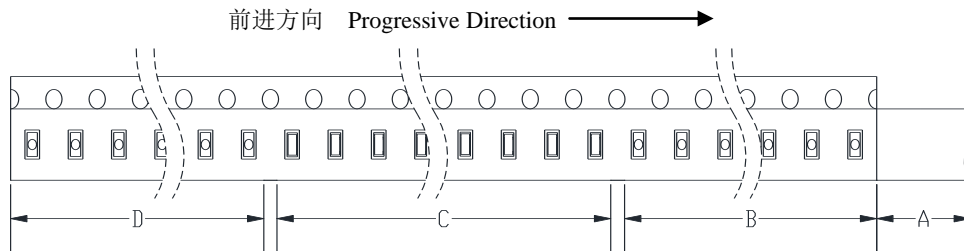

A: 盖带, 100 mm; B: 引导, 空带, 300mm; C: 编载产品 4000 只; D: 尾部, 空带, 200mm
 A: Top Cover Tape, 100mm; B: Leader, Empty, 300mm; C: 4000 Lamps Loaded; D: Trailer, Empty, 200mm.

◇ 带盘 Reel Dimension

前进方向 Progressive Direction →

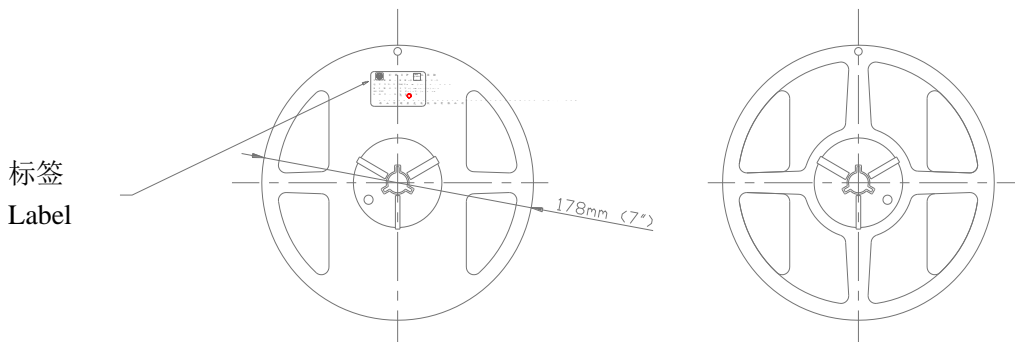

包装 (2)

Packaging(2)

❖ 防潮抗静电包装 Moisture Proof and Anti- Electrostatic Foil Bag

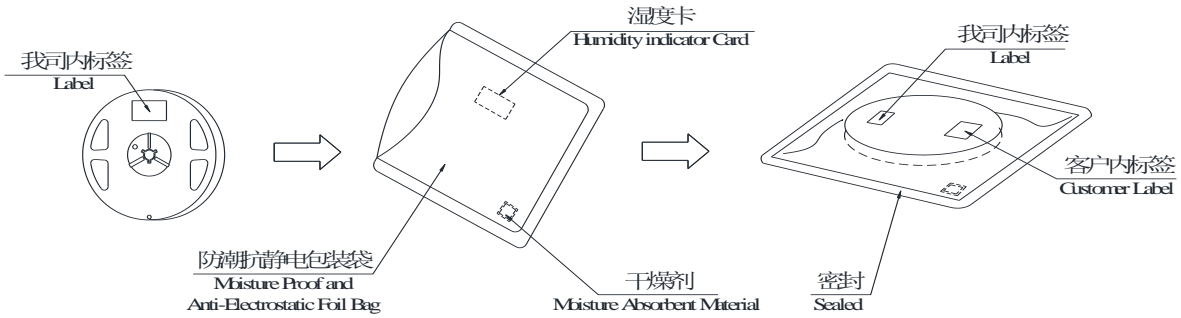

❖ 外包装箱 Cardboard Box

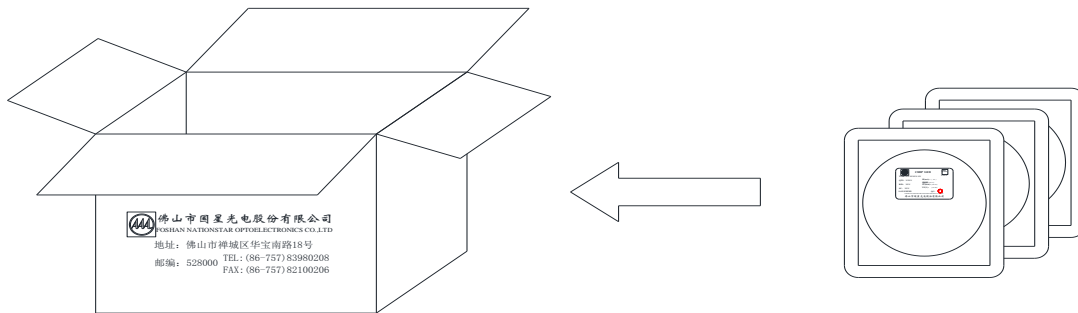

❖ 标签说明 Label Explanation

TYPE: 产品型号

IF: 测试电流 Testing Current

QTY: 数量 Quantity

BIN: 档次 Rank

VF: 正向电压范围 Forward Voltage Range

SC: 分档表编号 Step Code

LOT: 批号 Lot Number

