

THIS DOCUMENT IS THE PROPERTY OF
KEYSTONE ELECTRONICS CORP. AND
SHALL NOT BE REPRODUCED, DISTRIBUTED
OR USED AS A BASIS FOR MANUFACTURE
WITHOUT PRIOR WRITTEN PERMISSION
FROM KEYSTONE ELECTRONICS CORP.

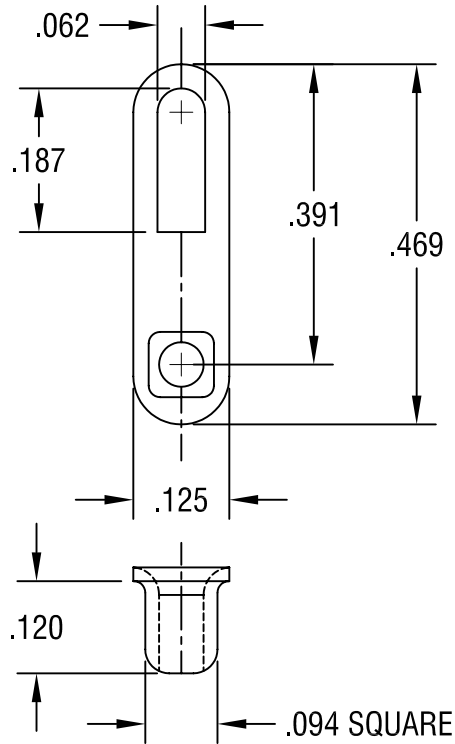

NOTE:

- 1. FINISH: .000100-.000300 TIN PLATE
OVER .000100-.000200 COPPER.

KEYSTONE ELECTRONICS CORP.

ASTORIA, N.Y. 11105-2017

PART NAME		SOLDER LUG	
MATERIAL		.018 TH'K BRASS	
FINISH	AS NOTED	DRN BY	BOONE
		APP'D	LN
		DATE	6.18.91
		SCALE	4X
TOLERANCES	INCH [MM]	CODE	DWG NO.
DECIMAL	$\pm .005$ [\pm]	F	F-1M
ANGULAR	$\pm 1^\circ$		
UNLESS OTHERWISE SPECIFIED			

11.10.06	REVISED DIMS TO SUIT PART ECN 06-074 MAT'L WAS STEEL	B
DATE	DESCRIPTION	REV.

Mouser Electronics

Authorized Distributor

Click to View Pricing, Inventory, Delivery & Lifecycle Information:

[Keystone Electronics:](#)

[F-1M](#)