

Product data sheet

Specifications



Harmony eXLhoist, standard,
Remote control, LED, 6 motion push
buttons, 2 auxiliary push buttons,
MBC (tandem)

ZART8LM

! Discontinued

! Discontinued on: Mar 31, 2023

! End-of-service on: Apr 15, 2023

Main

Range of product	Harmony eXLhoist
Product or component type	Hand-held remote control
Device short name	ZART
Control button type	6 configurable motion push-button 2 configurable auxiliary push-button

Complementary

Device application	Slave in multiple bridge control (tandem)
Material	Enclosure: PC (polycarbonate) Enclosure: PBT (polybutylene terephthalate) Cover: PP (polypropylene) Protective cover: EPDM rubber
Function available	Accelerometer function
Display type	4 LEDs
Operating distance	50 m
Mechanical robustness	Free fall resistance 4.5 m conforming to IEC 60068-2-27
Communication network type	Wireless: bluetooth low energy
transmission frequency	2.4 GHz
Maximum sensing distance	100 m in free field
Response time	< 300 ms at full duplex
Charging time	900 s
Autonomy	30 h
Mechanical durability	5000000 cycles
Service life	5 year(s)
Width	100 mm
Height	340 mm
Depth	90 mm
Net weight	0.65 kg

Environment

Radio agreement	RSS FCC ICASA SRRC ARIB ANATEL
IP degree of protection	IP65
NEMA degree of protection	NEMA 4
Ambient air temperature for operation	-20...60 °C
Ambient air temperature for storage	-20...45 °C
Operating altitude	0...2000 m
Storage altitude	0...3000 m
Vibration resistance	0.075 mm conforming to IEC 60068-2-6 (f = 10...55 Hz)
Shock resistance	100 gn conforming to IEC 60068-2-27
Relative humidity	0...95 % at -20...60 °C operating
Product certifications	EAC CSA C-Tick UL CE KC JIS

Packing Units

Unit Type of Package 1	PCE
Number of Units in Package 1	1
Package 1 Height	10.7 cm
Package 1 Width	10.2 cm
Package 1 Length	33.6 cm
Package 1 Weight	713 g
Unit Type of Package 2	CAR
Number of Units in Package 2	1
Package 2 Height	10.7 cm
Package 2 Width	10.2 cm
Package 2 Length	33.7 cm
Package 2 Weight	732 g
Unit Type of Package 3	S03
Number of Units in Package 3	4
Package 3 Height	30 cm
Package 3 Width	30 cm
Package 3 Length	40 cm
Package 3 Weight	3.641 kg

Sustainability

Green Premium™ label is Schneider Electric's commitment to delivering products with best-in-class environmental performance. Green Premium promises compliance with the latest regulations, transparency on environmental impacts, as well as circular and low-CO₂ products.

Guide to assessing product sustainability is a white paper that clarifies global eco-label standards and how to interpret environmental declarations.

[Learn more about Green Premium >](#)

[Guide to assess a product's sustainability >](#)

Well-being performance

 Mercury Free

 Rohs Exemption Information [Yes](#)

Eu Rohs Directive Pro-active compliance (Product out of EU RoHS legal scope)

China Rohs Regulation [China RoHS declaration](#)

Weee The product must be disposed on European Union markets following specific waste collection and never end up in rubbish bins

California Proposition 65 WARNING: This product can expose you to chemicals including: Nickel compounds, which is known to the State of California to cause cancer, and Di-isodecyl phthalate (DIDP), which is known to the State of California to cause birth defects or other reproductive harm. For more information go to www.P65Warnings.ca.gov

Dimensions Drawings

Dimensions

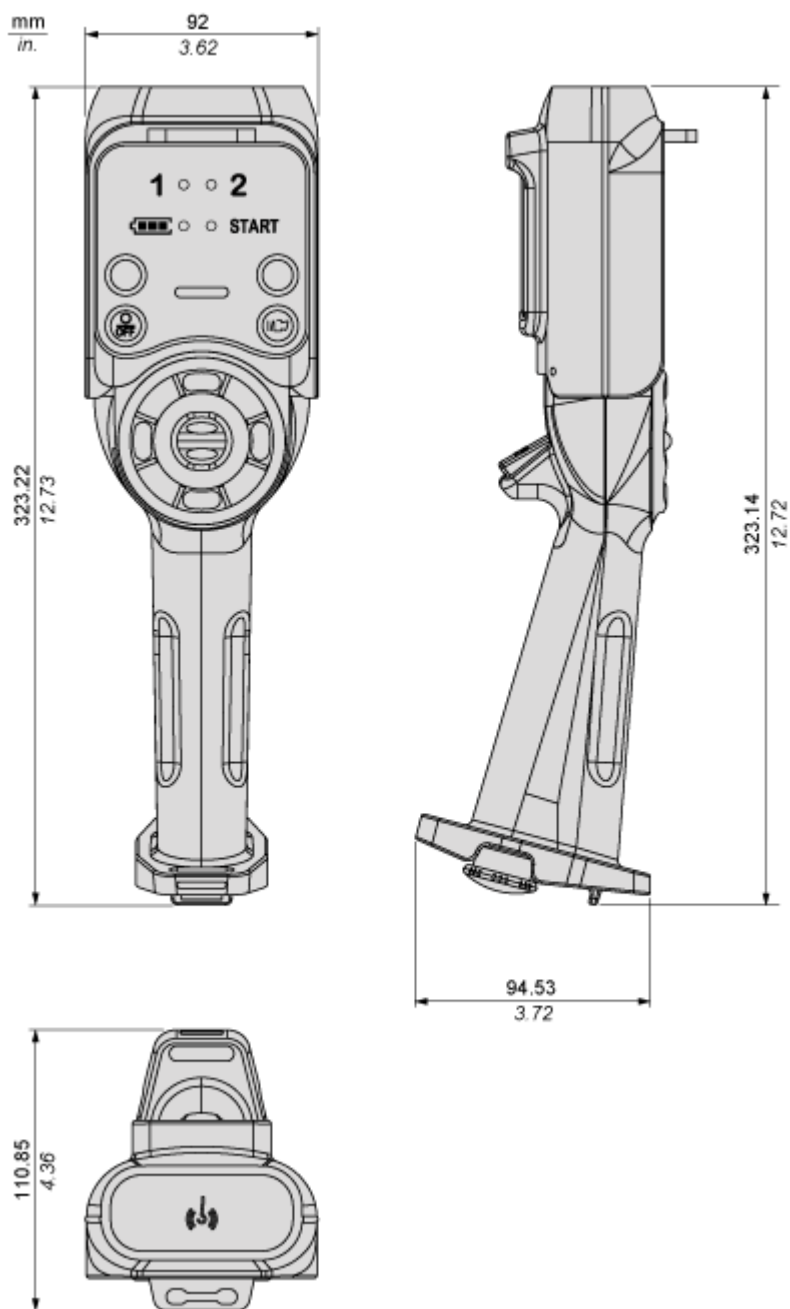

Technical Description

Multiple Bridge Control

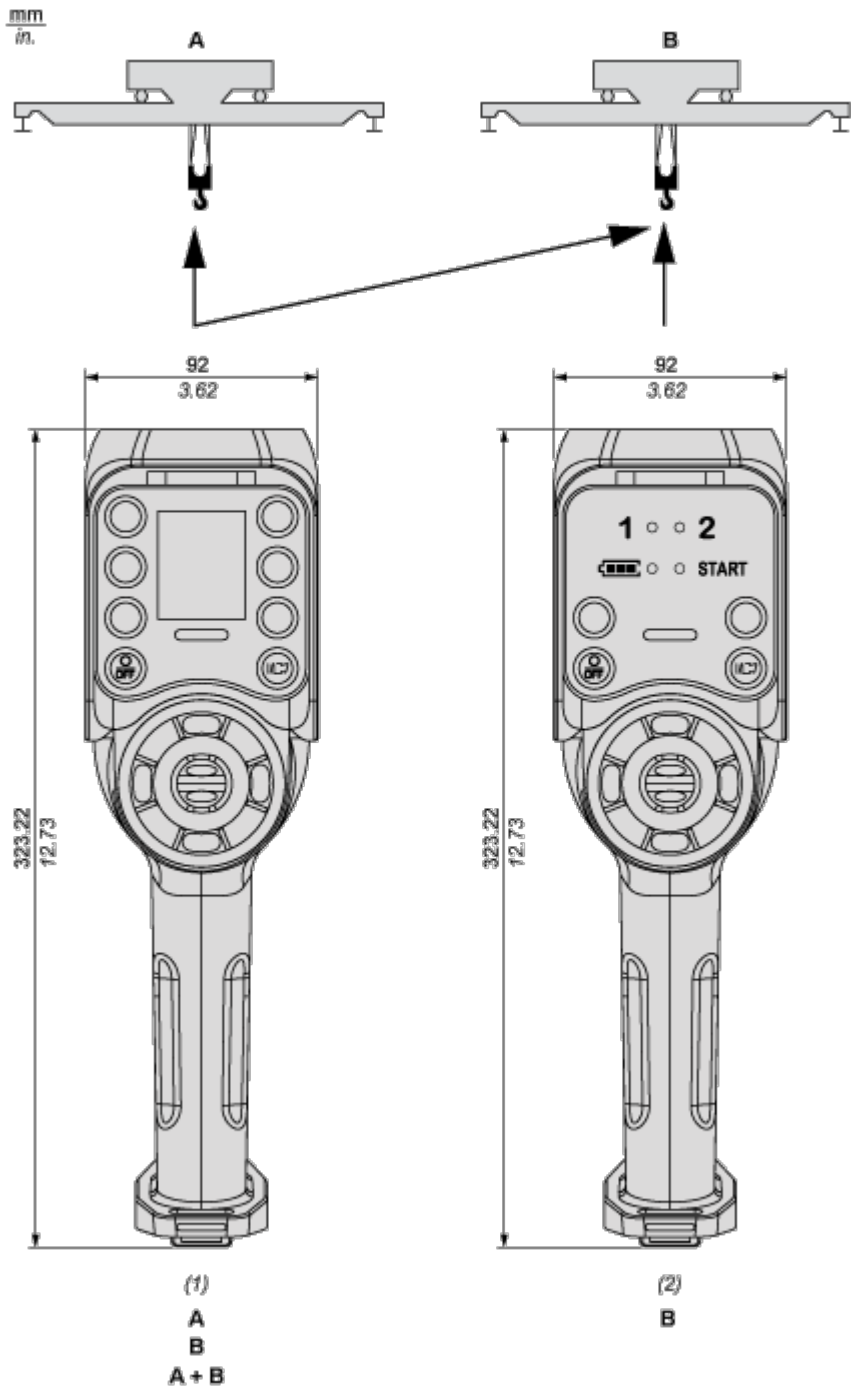

A : Bridge 1

B : Bridge 2

(1) Master

(2) Slave