

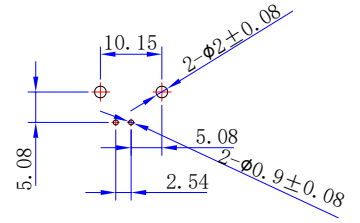

Product NO.		DOSIN-801-0030		
REV	DESCRIPTION	DWN	DATE	APPROVEN
A	First issue	Mr. CHEN	2017/12/13	John ki ne
B	See "Carmine" plece	XIEFENG	2022/07/18	

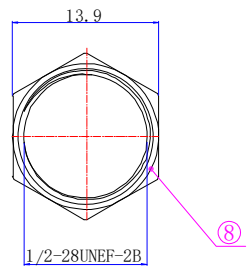
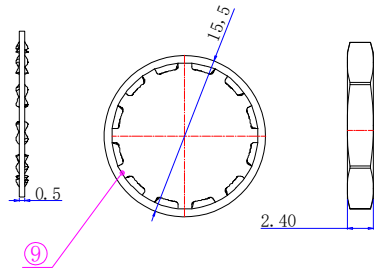
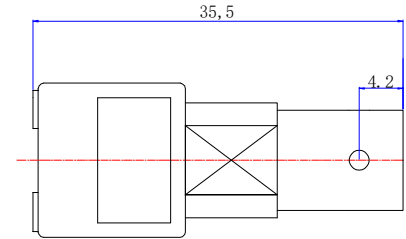
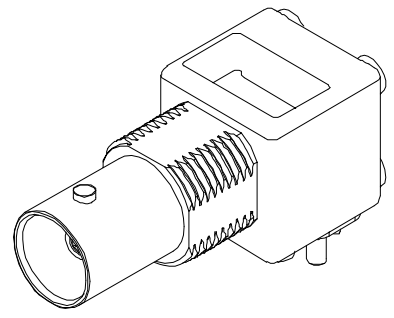
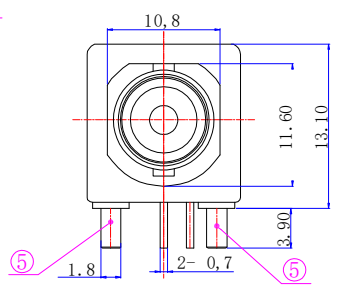
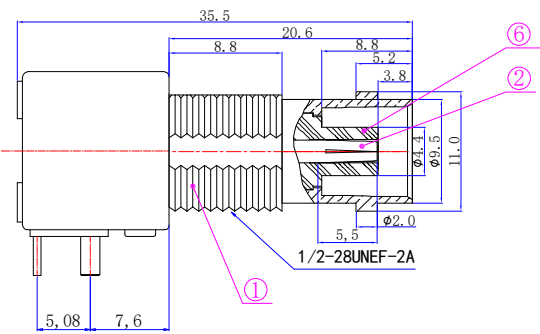
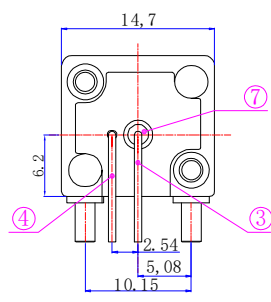

Specifications

Impedance:50 Ohms
 Frequency Range:DC 0~3G
 VSWR:1.3MAX
 Working Voltage:500V rms @ sea level
 Insulation Resistance:5000 MΩ
 Temperature Range:-55℃ T0 +155℃
 Relative Temperature:≤95%(40° C±2° C)
 Drawings products are in line with ROHS standards

1	Body	ZINC#3	NI: 80-120"	1	NOTE: DRAWN Zelin. CHEN 2017/12/ 13 CHECKED APPROVALS 13/12.2017
2	Center contact<1>	CI7200	AU: 0.8-1.0"	1	
3	Center contact<2>	Brass59-1	AU: 0.8-1.0"	1	
4	Ground	Iron	SN: 80-100"	1	
5	fixed foot	Iron	SN: 80-100"	2	
6	Insulator<1>	POM	White	1	
7	Insulator<2>	POM	White	1	
8	Nut	Brass59-1	NI: 80-120"	1	
9	washer	Iron	NI: 80-120"	1	
10					
NO	Component Number	Material	Finish	QTY	SCALE

Tolerance	X. ±0.15 X.X ±0.10 X.XX ±0.05 Angular ±5°
View	
UNIT	MM
SCALE	1:1

Dosin *Dosin Industrial (H K) Co. Ltd*
 东莞市德索五金电子制品有限公司
Dosin Hardware Electronics Co., Ltd
 E-mail:dosin2005@163.com
 dosin2005@dosin-china.com
 Web:http://www.dosinconn.com
 TEL: (0086) 769-81153906
 FAX: (0086) 769-81875836

Name: BNC JACK CONNECTOR
 SIZE A Product NO. DOSIN-801-0030 REV B
 DateTime 2017/12/13 CAD FILE D/company drawings/BD SHEET: 1 OF 1