

# Product Specification

XBLW DS18B20T

High precision digital sensor

WEB | [www.xinboleic.com](http://www.xinboleic.com)



## Description

DS18B20T is a all integrated digital thermometer provides 12-bit Celsius temperature measurements without any other external sensing unit. It can communicates over a 1-Wire bus that by definition requires only one data line (and ground) for communication with a central microprocessor, eliminating the need for strong pull up operating conditions, which effectively reduce MCU controller cost.

## Feature

- Low Cost, Replace DS18B20
- Replace Ntc Thermistor
- Each Device Has a Unique 64-Bit Serial Code Stored In On-Board Rid
- Measures Temperatures Accuracy:  $\pm 0.5^{\circ}\text{C}$
- Supply Voltage: 2.6V ~ 5.5V
- Operating Temperature:  $-55^{\circ}\text{C} \sim +150^{\circ}\text{C}$
- Conversion Current: 40 $\mu\text{A}$
- Standby Current: 0.5 $\mu\text{A}$
- Resolution: 12 Bits (0.0625 $^{\circ}\text{C}$ )
- Communication Interface: 1-Wire



## Applications

- Thermostatic Controls
- Industrial System Controls
- Cold Chain Transportation

## Ordering Information

Product Model	Package Type	Marking	Packing	Packing Qty
XBLW DS18B20T	TO-92	DS18B20T	Bag	2000Pcs/Bags

## Block Diagram

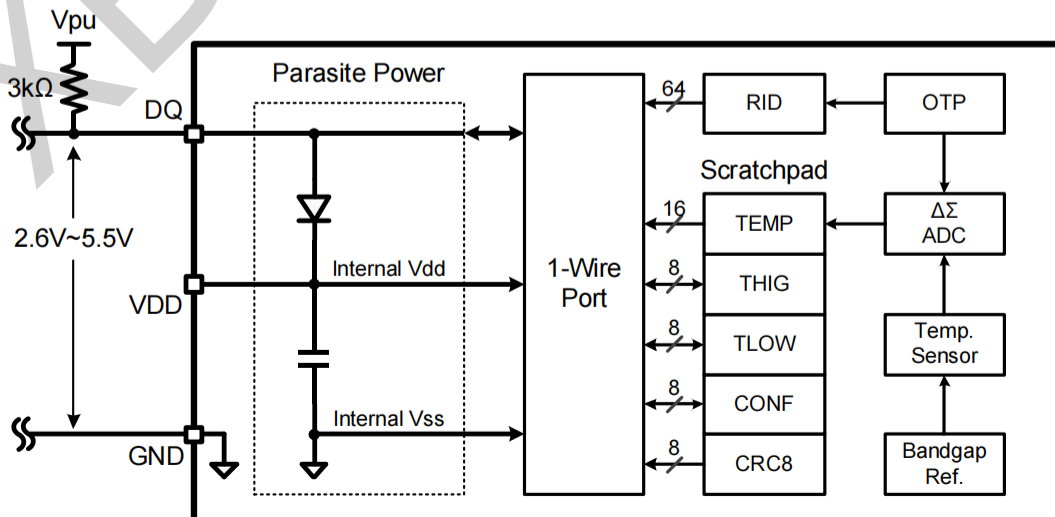

## Pins Configuration

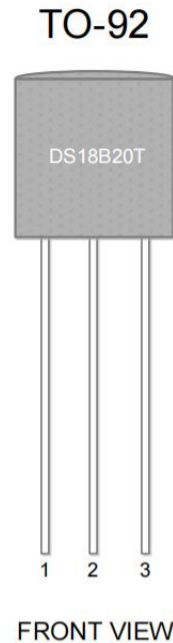

Name	Pin	Description
GND	1	Ground
DQ	2	Data Input/Output
VDD	3	Power Supply

Note: Under parasite-power mode, VDD must be drifted, not to ground.

## Technical Standards

### 1. Extreme Operation

	Min.	Max.	Unit
Supply Voltage Range	- 0.5	6	V
Temperature Range	- 55	150	°C
Junction Temperature		150	°C
Storage Temperature	- 60	150	°C

These are stress ratings only and functional operation of the device at these or any other conditions above those indicated in the operation sections of this specification is not implied. Exposure to absolute maximum rating conditions for extended periods of time may affect reliability

### 2. Electrostatic Protection

		Protection value	Unit
Electrostatic Discharge	Human Body Mode (HBM), per ANSI/ESDA/JEDEC JS-001	±4000	V
Latch-up	Latch-Up, per JESD 78, Class IA	±200	mA

## Electrical Characteristics

Unless otherwise specified, the following data are the characteristics of the chip in the temperature range of -40°C~+125°C and voltage range of 2.6V~5.5V. (Typical operating conditions are +25°C and 3.3V)

Parameters	Test conditions	Min.	Typ.I	Max.	Unit
Power Supply	Two-wire connection (DQ-GND)	2.6	3.3	5.5	V
	Three-wire connection (VDD-GND)	1.4	3.3	5.5	V
Operating Temperature		-55		150	°C
Temperature Measurement Accuracy	0°C ~ +85°C, 3.3V			± 0.5	°C
	-40°C ~ +125°C			±1	°C
Supply Voltage Sensitivity				0.1	°C/V
Resolution			0.0625		°C
			12		bits
Conversion Time			27	35	ms
Operating Current	Conversion period		40	80	μA
	standby mode		0.5	3	μA
Pull-Up Resistor		0.5	4.7	10	KΩ

## Typical Data

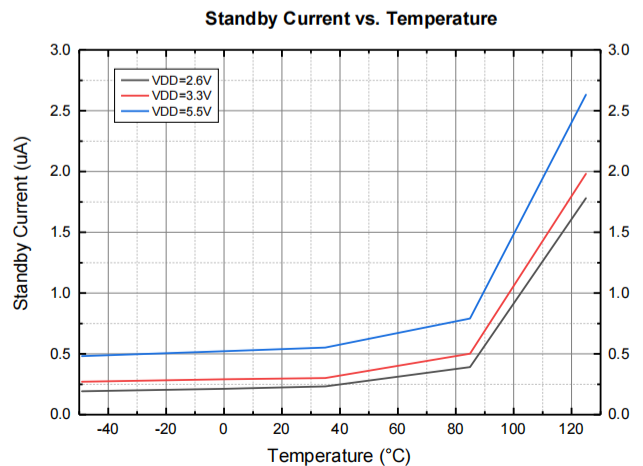
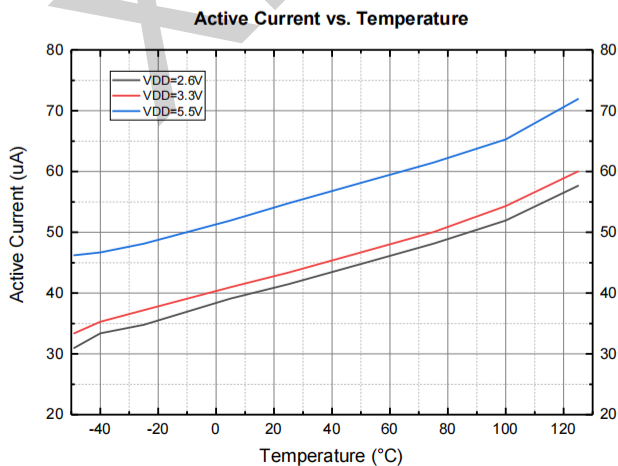
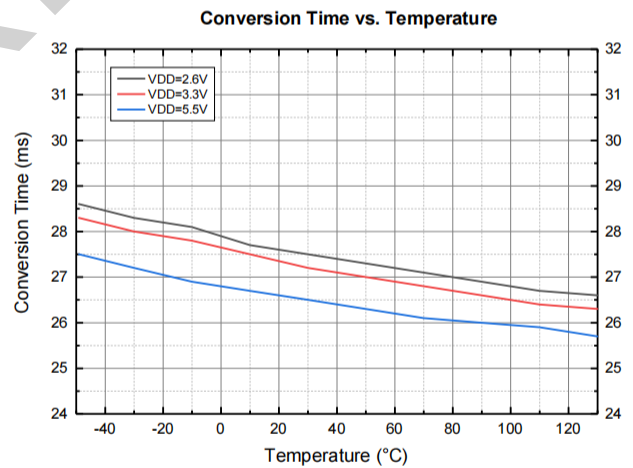
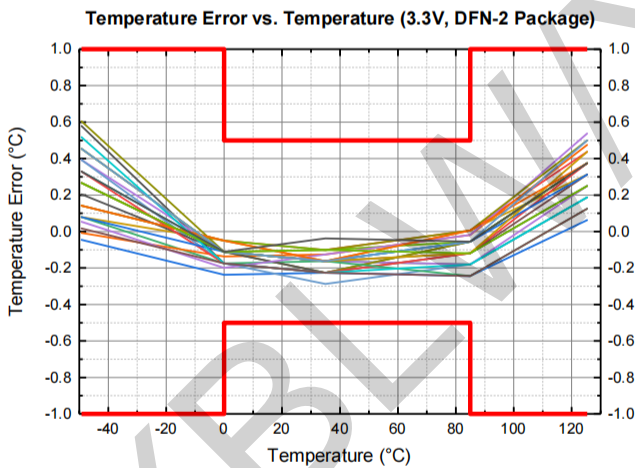

## Detailed Description

### Temperature Output

The 12-bit digital output of each temperature measurement is stored in a read-only temperature register, where 1 LSB = 0.0625°C, and negative numbers are represented in binary complement form. To obtain the temperature output, two bytes need to be read, where byte 1 is the low-significant byte and the following byte 2 is the high-significant byte. If a temperature range of 128°C and above needs to be measured, the user must enable extended mode (EM = 1) through the 1-Wire interface configuration.

Table 1,2 Several examples of digital output and corresponding temperature are listed .

The power-on default value of the temperature register is 85°C (=0x0550).

Table 1. Temperature Data Format (EM=0)

Temperature (°C)	Digital Output (Binary)				Digital Output (Hex)
150	0000	0111	1111	1111	07FF
127.9375	0000	0111	1111	1111	07FF
125	0000	0111	1101	0000	07D0
85	0000	0101	0101	0000	0550
27	0000	0001	1011	0000	01B0
0.0625	0000	0000	0000	0001	0001
0	0000	0000	0000	0000	0000
-0.0625	1111	1111	1111	1111	FFFF
-55	1111	1100	1001	0000	FC90

Table 2. Temperature Data Format (EM=1)

Temperature (°C)	Digital Output (Binary)				Digital Output (Hex)
150	0000	1001	0110	0000	0960
127.9375	0000	0111	1111	1111	07FF
125	0000	0111	1101	0000	07D0
85	0000	0101	0101	0000	0550
27	0000	0001	1011	0000	01B0
0.0625	0000	0000	0000	0001	0001
0	0000	0000	0000	0000	0000
-0.0625	1111	1111	1111	1111	FFFF
-55	1111	1100	1001	0000	FC90

Note: Table 1, 2 Data formats are not available for all temperatures.

## Register Map

The internal buffer of DS18B20T consists of five registers, the mapping relationship is as follows: [table 3](#) The specific contents of the register are as shown in [Tables 4~12](#) shown.

Table 3. Register Map

Byte	Register	Symbol	Attributes	Default Value
1	Temperature	TEMP	R	0x50
2			R	0x05
3	High Threshold	THIG	R/W	0x55
4	Low Threshold	TLOW	R/W	0x00
5	Configuration Word	CONF	R/W	0x7F
6	Reserve	-	R	0xFF
7	Reserve	-	R	0x0C
8	Reserve	-	R	0x10
9	Check Code	CRC8	R	0x21

Note: R stands for read-only; R/W stands for read-write.

Table 4. Temperature Register (EM=0)

Bit	15	14	13	12	11	10	9	8	7	6	5	4	3	2	1	0
Binary	T15	T14	T13	T12	T11	T10	T9	T8	T7	T6	T5	T4	T3	T2	T1	T0
Temperature	sign	sign	sign	sign	sign	64	32	16	8	4	2	1	2-1	2-2	2-3	2-4
Attributes	R	R	R	R	R	R	R	R	R	R	R	R	R	R	R	R

Note: R stands for read-only; R/W stands for both read and write. Sign is the sign bit, 0 = positive number, 1 = negative number.

Table 5. Temperature Register (EM=1)

Bit	15	14	13	12	11	10	9	8	7	6	5	4	3	2	1	0
Binary	T15	T14	T13	T12	T11	T10	T9	T8	T7	T6	T5	T4	T3	T2	T1	T0
Temperature	sign	sign	sign	sign	128	64	32	16	8	4	2	1	2-1	2-2	2-3	2-4
Attributes	R	R	R	R	R	R	R	R	R	R	R	R	R	R	R	R

Note: R stands for read-only; R/W stands for both read and write. Sign is the sign bit, 0 = positive number, 1 = negative number.

Table 6. High Threshold Register (EM=0)

Bit	7	6	5	4	3	2	1	0
Binary	H7	H6	H5	H4	H3	H2	H1	H0
Temperature	sign	64	32	16	8	4	2	1
Attributes	R/W	R/W	R/W	R/W	R/W	R/W	R/W	R/W

Note: R stands for read-only; R/W stands for both read and write. Sign is the sign bit, 0 = positive number, 1 = negative number.

Table 7. High Threshold Register (EM=1)

Bit	7	6	5	4	3	2	1	0
Binary	H7	H6	H5	H4	H3	H2	H1	H0
Temperature	sign	128	64	32	16	8	4	2
Attributes	R/W	R/W	R/W	R/W	R/W	R/W	R/W	R/W

Note: R stands for read-only; R/W stands for both read and write. Sign is the sign bit, 0 = positive number, 1 = negative number.

Table 8. Low Threshold Register (EM=0)

Bit	7	6	5	4	3	2	1	0
Binary	L7	L6	L5	L4	L3	L2	L1	L0
Temperature	sign	64	32	16	8	4	2	1
Attributes	R/W	R/W	R/W	R/W	R/W	R/W	R/W	R/W

Note: R stands for read-only; R/W stands for both read and write. Sign is the sign bit, 0 = positive number, 1 = negative number.

Table 9. Low Threshold Register (EM=1)

Bit	7	6	5	4	3	2	1	0
Temperature	sign	128	64	32	16	8	4	2
Attributes	R/W	R/W	R/W	R/W	R/W	R/W	R/W	R/W

Note: R stands for read-only; R/W stands for both read and write. Sign is the sign bit, 0 = positive, 1 = negative.

Table 10. Configuration Register

Bit	7	6	5	4	3	2	1	0
Binary	EM	-	-	-	-	-	-	-
Default Value	0	1	1	1	1	1	1	1
Attributes	R/W	R	R	R	R	R	R	R

Note: R stands for read-only; R/W stands for both read and write. - stands for reserved bits.

Table 11. Configuration register contents description

Parameters	Description
EM	Extended Mode EM=0: Output 12-bit temperature, the range is (-128°C ~ +127.9375°C). Temperature above the range is automatically clamped to +127.9375°C EM=1: Output 13-bit temperature, the range is (-256°C ~ +255.9375°C)

Note: The extended mode only changes the temperature display range but does not change the temperature resolution.

Table 12. Check Registers

Bit	7	6	5	4	3	2	1	0
Binary	C7	C6	C5	C4	C3	C2	c1	C0
Default Value	1	1	1	0	0	0	1	1
Attributes	R	R	R	R	R	R	R	R

Note: R stands for read-only; R/W stands for readable and writable. The verified data is the first eight bytes of the buffer area.

## Serial Interface

### 3.1 Bus Overview

The 1-Wire bus is a single-master multi-slave communication system that uses only a single signal line. All slaves on the bus need to drive the bus at the appropriate time, so they must be mounted on the bus in the form of open-drain output. The 1-Wire bus stipulates a two-level command architecture consisting of addressing commands and function commands. Among them, addressing commands are generally universal between different types of devices, mainly used to select specific slaves on the bus to execute subsequent function commands; while function commands are different depending on the device type and application. The addressing commands supported by DS18B20T are as follows: [Table 13](#) As shown, the function command is as follows [Table 14](#) shown. All data and commands transmitted on the 1-Wire bus are sent in the order of least significant bit first (LSB first).

Table 13. Addressing Commands

Code	Command	Description
0xF0	Search	Search for RID
0xEC	Alarm Search	Search for RID (only slaves with over-temperature alarm participate)
0x33	Read	Reading RID
0x55	Match	Matching RID
0xCC	Skip	Skip RID

Table 14. Function Commands

Code	Command	Description
0x44	Convert	Start temperature conversion
0xBE	Read Scratchpad	Read cache data
0x4E	Write Scratchpad	Write cache data

### 3.2 Node Address

The DS18B20T has a unique 64-bit RID used as a node address in the 1-Wire bus. [Table 15](#) As shown, the lowest 8 bits are the family code of DS18B20T; the middle 48 bits are the serial number. XBLW ensures that each DS18B20T shipped out of the factory is unique; the highest 8 bits are the checksum for the family code and serial number.

Table 15. Node Address (RID)

Bit	[63:56]	[55:8]	[7:0]
Binary	Check code	Serial Number	Family Code
Value	Corresponding Calculation	Each Unique	0x28

### 3.3 Signal Timing



The 1-Wire bus defines six basic signal types: reset pulse, response pulse, read 0 , read 1 , write 0 , and write 1 . Except for the response pulse, all signals are initiated by the master and start counting from the falling edge of the bus.

The initialization sequence consisting of a reset pulse followed by an acknowledge pulse is the starting step for all communications on the 1-Wire bus. Figure 1As shown. The host sends a reset pulse to the bus by pulling the bus low for 480us. After the DS18B20T recognizes the reset pulse, it resets its own communication state and sends a response pulse. In order to detect the response pulse, the host must sample the bus within a specific window time. When the bus is sampled as logic low, it means that there is a response pulse, indicating that the DS18B20T is ready to start communication; when the bus is sampled as logic high, it means that there is no response pulse, indicating that the reset pulse is not recognized by the DS18B20T, or the DS18B20T is not mounted on the bus. In order to maximize the timing margin, XBLW recommends sampling the bus at 70us.

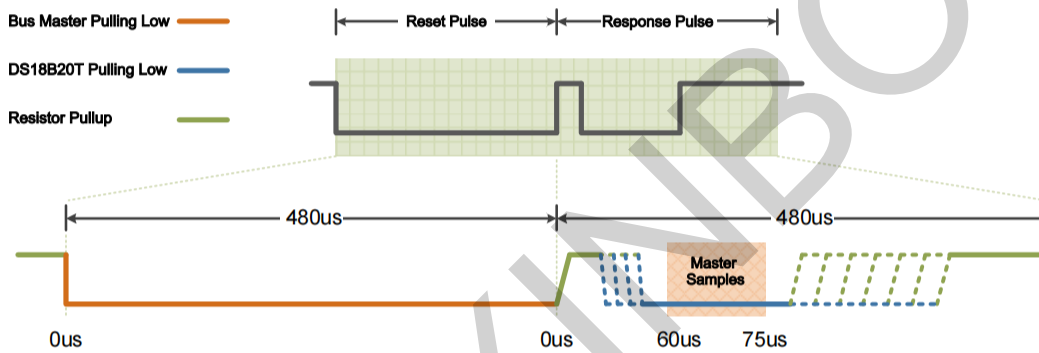

Figure1. Initialization Timing

1-Wire data transmission is based on time slots, which carry only one bit of data at a time. The write time slot transfers the data sent by the host to the chip; the read time slot transfers the data sent by the chip to the host. Both the read and write time slots start when the host pulls down the bus. figure 2As shown in Figure 1, the time slot width is not shorter than 65us; the recovery time between adjacent time slots must be not shorter than 1us. The two together determine the maximum possible communication rate of the 1-Wire bus to be 15kbps.

DS18B20T can send data to the host only when the host starts the read time slot. After the host pulls down the bus to start the read time slot, it must maintain at least 1us to ensure that the falling edge of the bus can be recognized by DS18B20T. If DS18B20T successfully recognizes it, it will decide the subsequent operation of the bus based on the data it is about to send. Therefore, the read time slot can be further divided into the following two signals:

- Read 0 : starting from the falling edge of the bus, pull the bus low and maintain for 15~60us;
- Read 1 : starts from the falling edge of the bus and releases the bus directly.

In order to receive the data sent by DS18B20T, the host must sample the bus within a specific window time, and the sampling result is the received one bit of data. In order to maximize the timing margin, XBLW recommends releasing the bus at 5us and sampling the bus at 15us.

The host sends data to the DS18B20T by starting the write time slot. After the host pulls down the bus to start the write time slot, it must maintain at least 1us to ensure that the falling edge of the bus can be recognized by the DS18B20T. If the DS18B20T recognizes successfully, it will sample the bus within a

specific window time. The sampling result is a bit of data received by the DS18B20T. Therefore, the write time slot can be further divided into the following two signals:

- Write 0 : After the host pulls down the bus, it must maintain at least 60us to release the bus;
- Write 1 : After the host pulls the bus low, it must release the bus within 15us.

The type of time slot initiated by the host is determined by the command itself. There may be both read time slots and write time slots in one communication process. Therefore, XBLW recommends that the host must be configured in open-drain output mode and never reconfigure the port or switch the input and output mode during communication.

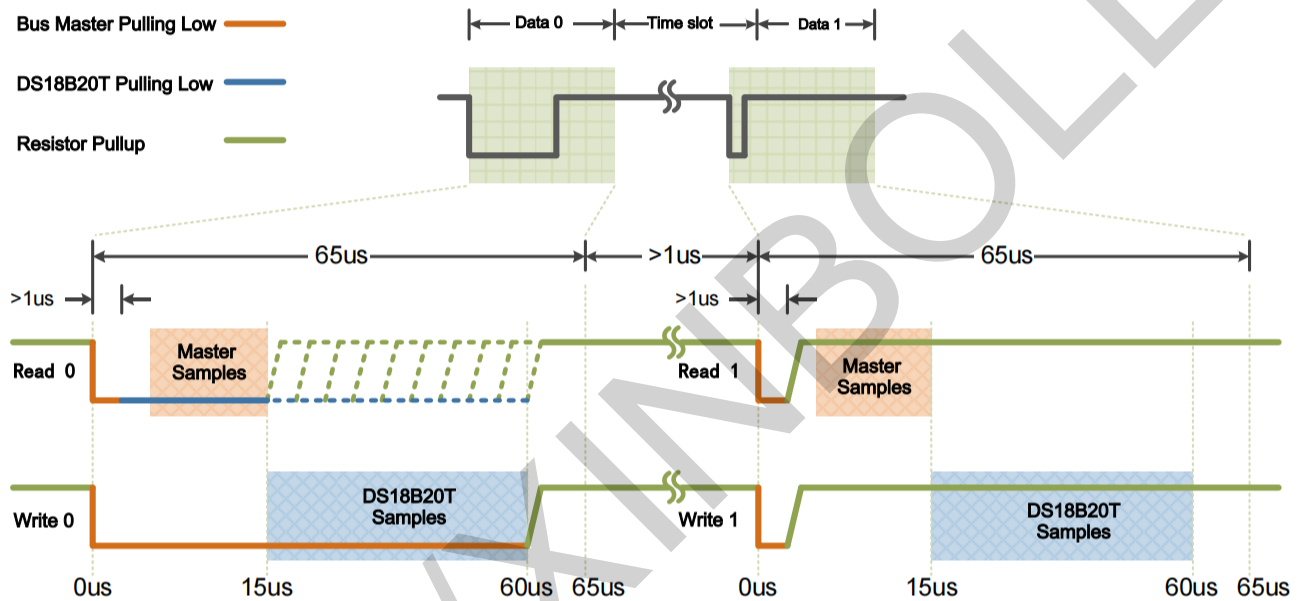

Figure 2 . Read/Write Time Slot Diagram

### 3.4. Communication Process

After DS18B20T is powered on, it takes about 3ms to stabilize, during which any communication operation is prohibited. The subsequent communication process is as follows:

- Step-1: The host sends an initialization sequence;
- Step-2: The host sends an addressing command and performs necessary data exchange.
- Step-3: The host sends a function command and performs necessary data exchange.

The user must strictly follow the communication process. Any missing step or disorder will cause DS18B20T to be unresponsive. The complete communication process is as follows: image 3The only exception is when the search command (0xF0 and 0xEC) is used in the search process, the host does not need to perform Step-3.

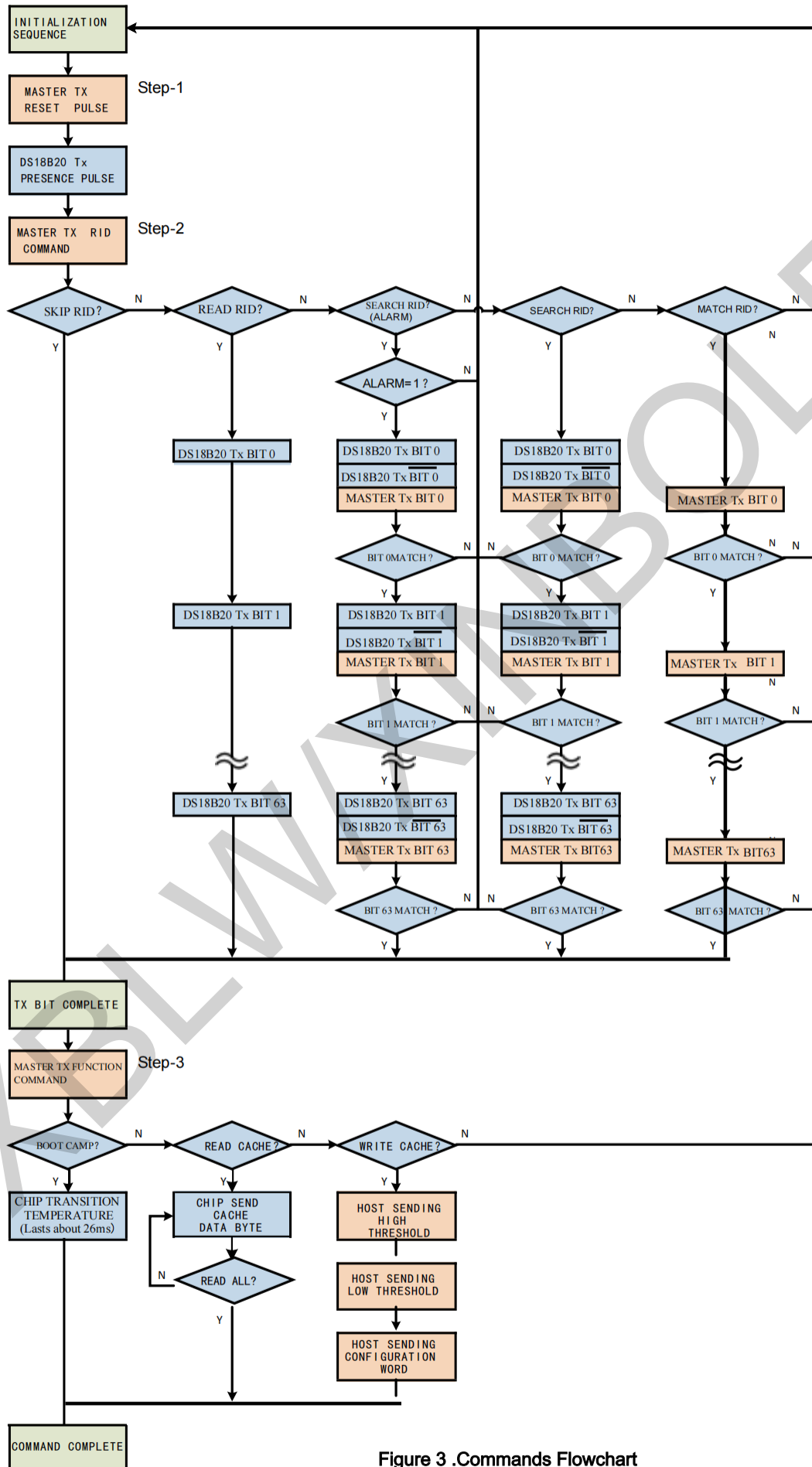

Figure 3 .Commands Flowchart

After the initialization sequence is complete, the master can send an addressing command to select a specific slave. The DS18B20T supports the following five addressing commands.

- Search RID (Search, 0xF0)

When the system is initially started, the host must identify the RID of all slaves on the bus to confirm the type and number of slaves mounted on the bus. The 1-Wire bus uses an elimination method to identify the slave RID. This process requires the host to loop through multiple search processes to traverse all slaves on the bus.

The search process consists of a Search command and necessary data exchange. Data exchange starts with the lowest bit of RID. For each bit of RID, the host needs to start three time slots in succession. In the first time slot, the slave participating in the search will send the true value of its RID at that bit; and in the second time slot, the slave participating in the search will send the inverse value of its RID at that bit. According to the wire-AND characteristic of the open-drain structure, the bus output value is the bitwise AND of the values sent by all slaves, and the information expressed by each of the following four situations can be inferred:

- The true value is 0, and the inverse value is 0: the RIDs of the slaves participating in the search differ in this bit;
- The true value is 0, the inverse value is 1: the RID of the slaves participating in the search is 0 in this bit;
- The true value is 1, and the inverse value is 0: the RID of the slaves participating in the search is 1 in this bit;
- True value is 1, negated value is 1: bus fault, or the slave is removed during the search process.

The host needs to decide the selected value based on the read results of the first two time slots and send it in the third time slot. All slaves whose RID is different from the host's selected value in this bit will exit the subsequent search process. The above process is repeated 64 times, and this round of search process ends. The 64-bit selected value sent by the host is the RID of a slave on the bus. Repeating multiple rounds can identify all slaves. For the specific decision-making process of branch selection, please refer to the "DS18B20T Driver User Manual".

- Search Alarm (Alarm Search, 0xEC)

This command is almost identical to the Search RID command (0xF0), except that only slaves with the ALARM flag set will participate in the search process. When the DS18B20T performs a temperature conversion, if the temperature output is outside the user-defined high and low temperature alarm thresholds, the ALARM flag will be set.

- Read RID (Read, 0x33)

This command directly reads the 64-bit RID of the slave. If there is only one slave on the bus, this command can more easily identify its RID. However, if there are multiple slaves on the bus, all slaves will send their own RIDs at the same time, causing data conflicts on the bus. Users should avoid this situation.

- Match RID (Match, 0x55)

This command needs to be accompanied by the desired 64-bit RID. Only slaves with fully matched RIDs will execute subsequent function commands.

- Skip RID (Skip, 0xCC)

This command directly selects all slaves on the bus. In conjunction with the Start Temperature Conversion command (0x44) or the Write Cache Data command (0x4E), the global access function can be implemented to operate all slaves at the same time. However, this command cannot be used with the Read Cache Data command (0xBE), otherwise all slaves will send their own data at the same time, causing data conflicts on the bus. Users should avoid this situation.

The addressed slave can receive and execute subsequent function commands. DS18B20T supports the following three function commands.

- Conversion (Convert, 0x44)

This command starts a temperature conversion and saves the temperature measurement result in a read-only temperature register. Compared with DS18B20, the conversion power consumption of DS18B20T is extremely low, so the host does not need to provide a strong pull-up condition during the conversion. However, it should be noted that the host must wait until the conversion is completed before communicating with DS18B20T, otherwise it may affect the temperature measurement accuracy, and may even cause the chip to power off and reset when the two-wire connection is in progress.

- Read Scratchpad (0xBE)

This command allows the host to read the entire internal buffer of the DS18B20T. Data transfer starts with the least significant bit of byte 1 and ends with the most significant bit of byte 9. If only the first part of the buffer data is needed, the host can send a reset pulse at any time to terminate subsequent reading.

- Write Scratchpad (0x4E)

This command allows the host to modify part of the internal buffer of DS18B20T. Data transmission starts at the lowest bit of byte 3 and ends at the highest bit of byte 5. Data is saved in the buffer in bytes. If the host sends a reset pulse in the middle of a byte, the data of that byte will be lost.

### 3.5 Calibration Principle

DS18B20T performs a cyclic redundancy check (CRC) on both RID and buffer data. The calculation rules are as follows: [Table 16](#)As shown, the generator is [Figure 4](#)The host should recalculate the CRC value and compare it with the received CRC value to verify whether the data read from the DS18B20T has bit errors.

16.CRC Calculation Rules

Item	Value	Item	Value
Check Width	8-bits	Input Data Inversion	no
Generating Polynomials	$x^8 + x^5 + x^4 + 1$	Output Data Inversion	no
Initial Preset Value	0x00	Result XOR value	0x00

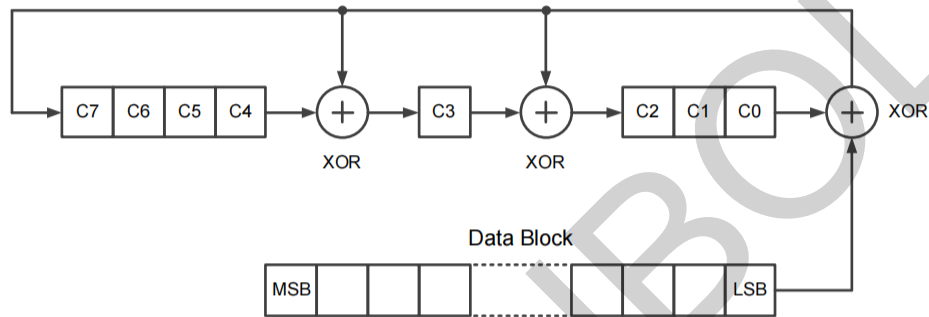

Figure 4 . CRC Generator

Power Supply

1. Parasitic Power Supply

When using a two-wire connection, the DS18B20T operates in a parasitic power supply state. When the bus is logically high, the DS18B20T "steals" current from the 1-Wire bus and powers the internal modules; when the bus is logically low, the DS18B20T uses the charge stored in the internal large capacitor to power the internal modules. The diode ensures that the capacitor charge will not leak in the reverse direction during the communication process. The connection diagram of parasitic power supply is shown in the figure below. Figure 5 shown.

Parasitic power supply is very suitable for remote temperature measurement applications and can effectively save cable costs. However, for high temperature applications (>125°C), XBLW does not recommend the use of parasitic power supply, because semiconductor devices have large leakage currents at high temperatures, which may cause the capacitor charge to be unable to maintain normal communication.

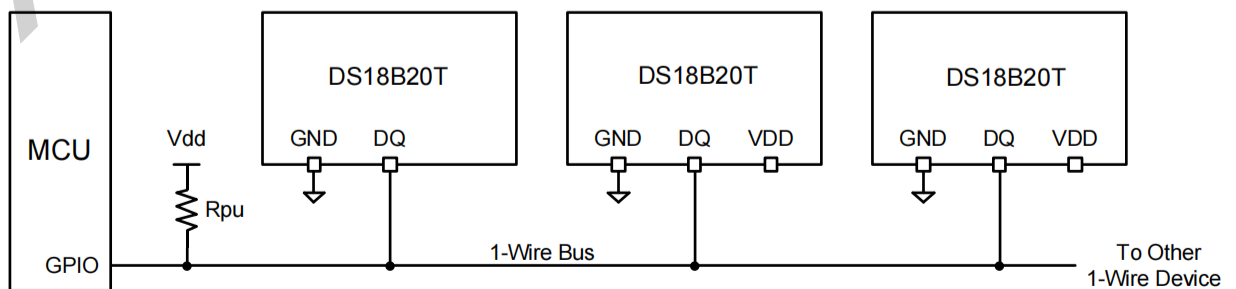

Figure 5 . Parasite-power Connection Diagram

## 2. External Power Supply

DS18B20T can be connected with three wires and work in external power supply state, such as

Figure 6 At this time, the minimum operating voltage of the chip can drop to 1.4V.

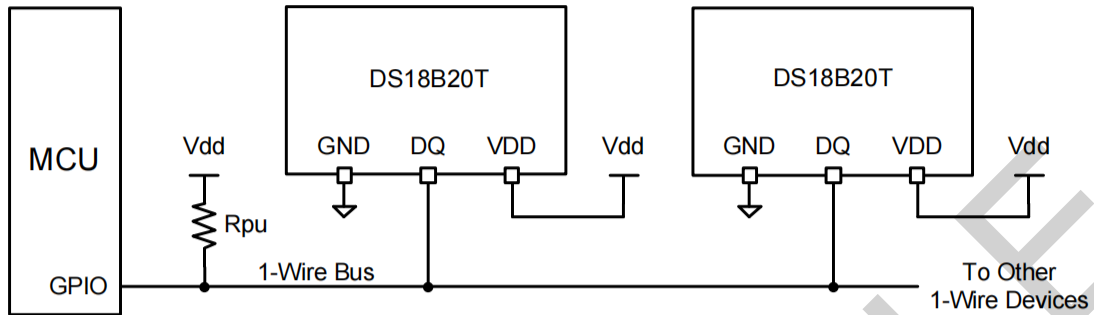

Figure 6 . External Power Supply Connection Diagram

## APPLICATION

### Notice

The following content is the precautions and usage suggestions of DS18B20T in specific applications. XBLW does not guarantee its accuracy or completeness. Users should evaluate whether it meets the target purpose in advance according to their own usage needs and application scenarios, and test and verify the correctness of the system functions to avoid losses.

### 1. High Temperature Applications

For high temperature applications ( $>125^{\circ}\text{C}$ ), XBLW recommends using an external power supply.

Users can take the following three measures to mitigate the impact of high temperature on parasitic power supply:

- Place a capacitor greater than 10uF between the power pin and the ground pin.
- Increase the pull-up supply voltage as high as possible and use a pull-up resistor smaller than 3kΩ.
- Shorten the reset pulse duration to 300us; increase the recovery time of adjacent time slots to 30us.

### 2. Layout Suggestions

DS18B20T should be kept as far away from noise sources as possible, such as high-speed digital buses, coil components, and wireless antennas. When three-wire connection is adopted, XBLW recommends placing a low ESR ceramic capacitor between the power pin and the ground pin to filter out power noise. The capacitor needs to be as close to the power pin as possible, and the recommended value is 0.1uF.

The DS18B20T should be placed as close as possible to the heat source being monitored, and proper layout should be used to achieve good thermal coupling to ensure that temperature changes are captured in the shortest possible time interval. The average power consumption of the DS18B20T is very low, and the self-heating generated by the power consumption can be ignored.

Package Information

· T0-92

Symbol	Dimensions In Millimeters		Symbol	Dimensions In Inches	
	Min (mm)	Max (mm)		Min (in)	Max (in)
A	3.300	3.700	A	0.130	0.146
A1	1.100	1.400	A1	0.043	0.055
b	0.380	0.550	b	0.015	0.022
c	0.360	0.510	c	0.014	0.020
D	4.300	4.700	D	0.169	0.185
D1	3.430		D1	0.135	
E	4.300	4.700	E	0.169	0.185
e	1.270 (TYP)		e	0.050 (TYP)	
e1	2.440	2.640	e1	0.096	0.104
L	14.10	14.50	L	0.555	0.571
Φ		1.600	Φ		0.063
h	0.000	0.380	h	0.000	0.015

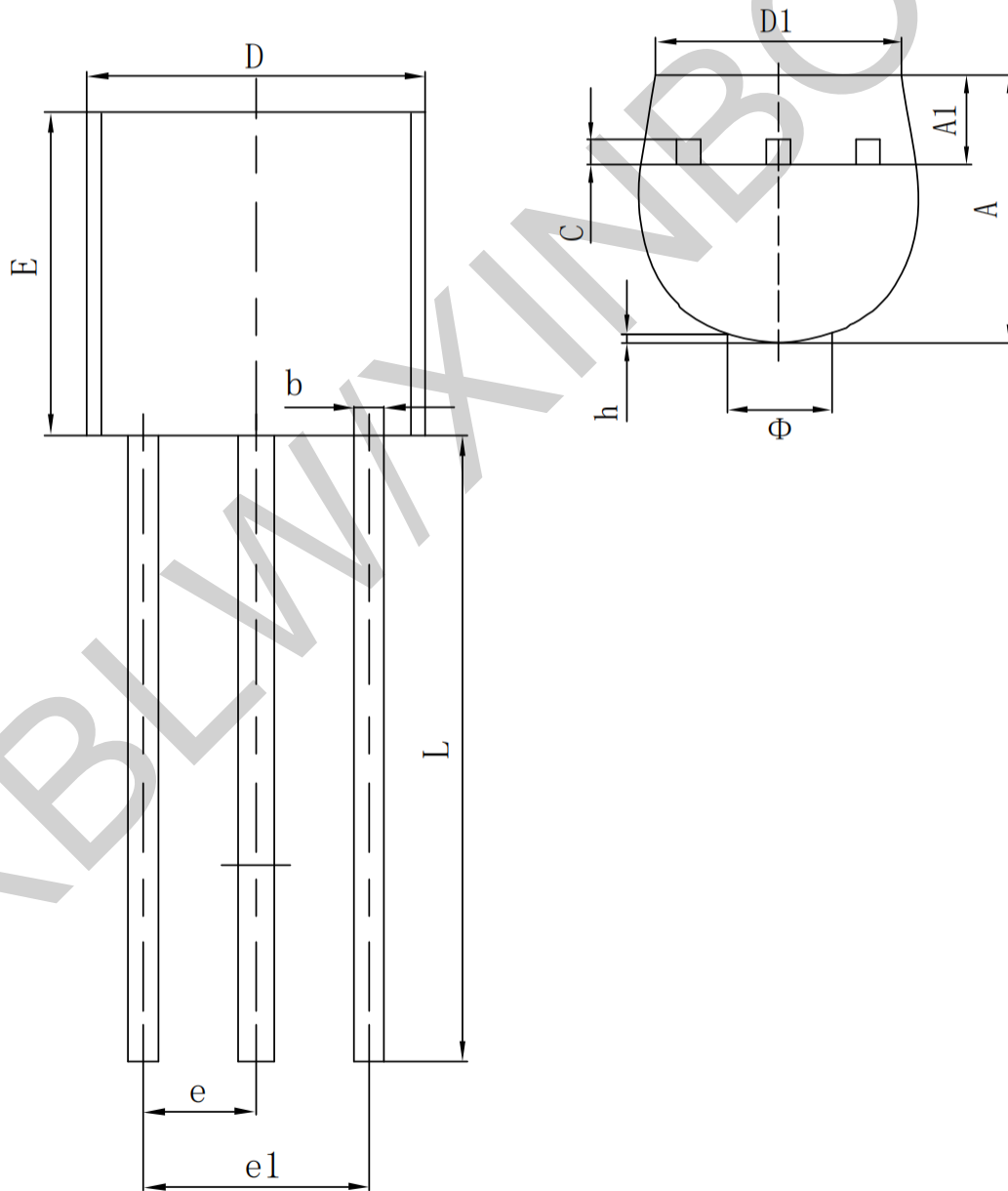



## Statement:

- XBLW reserves the right to modify the product manual without prior notice! Before placing an order, customers need to confirm whether the obtained information is the latest version and verify the completeness of the relevant information.
- Any semi-guide product is subject to failure or malfunction under specified conditions. It is the buyer's responsibility to comply with safety standards when using XBLW products for system design and whole machine manufacturing. And take the appropriate safety measures to avoid the potential in the risk of loss of personal injury or loss of property situation!
- XBLW products have not been licensed for life support, military, and aerospace applications, and therefore XBLW is not responsible for any consequences arising from the use of this product in these areas.
- If any or all XBLW products (including technical data, services) described or contained in this document are subject to any applicable local export control laws and regulations, they may not be exported without an export license from the relevant authorities in accordance with such laws.
- The specifications of any and all XBLW products described or contained in this document specify the performance, characteristics, and functionality of said products in their standalone state, but do not guarantee the performance, characteristics, and functionality of said products installed in Customer's products or equipment. In order to verify symptoms and conditions that cannot be evaluated in a standalone device, the Customer should ultimately evaluate and test the device installed in the Customer's product device.
- XBLW documentation is only allowed to be copied without any alteration of the content and with the relevant authorization. XBLW assumes no responsibility or liability for altered documents.
- XBLW is committed to becoming the preferred semiconductor brand for customers, and XBLW will strive to provide customers with better performance and better quality products.