

DATE CODE LOCATION
SEE NOTE 6

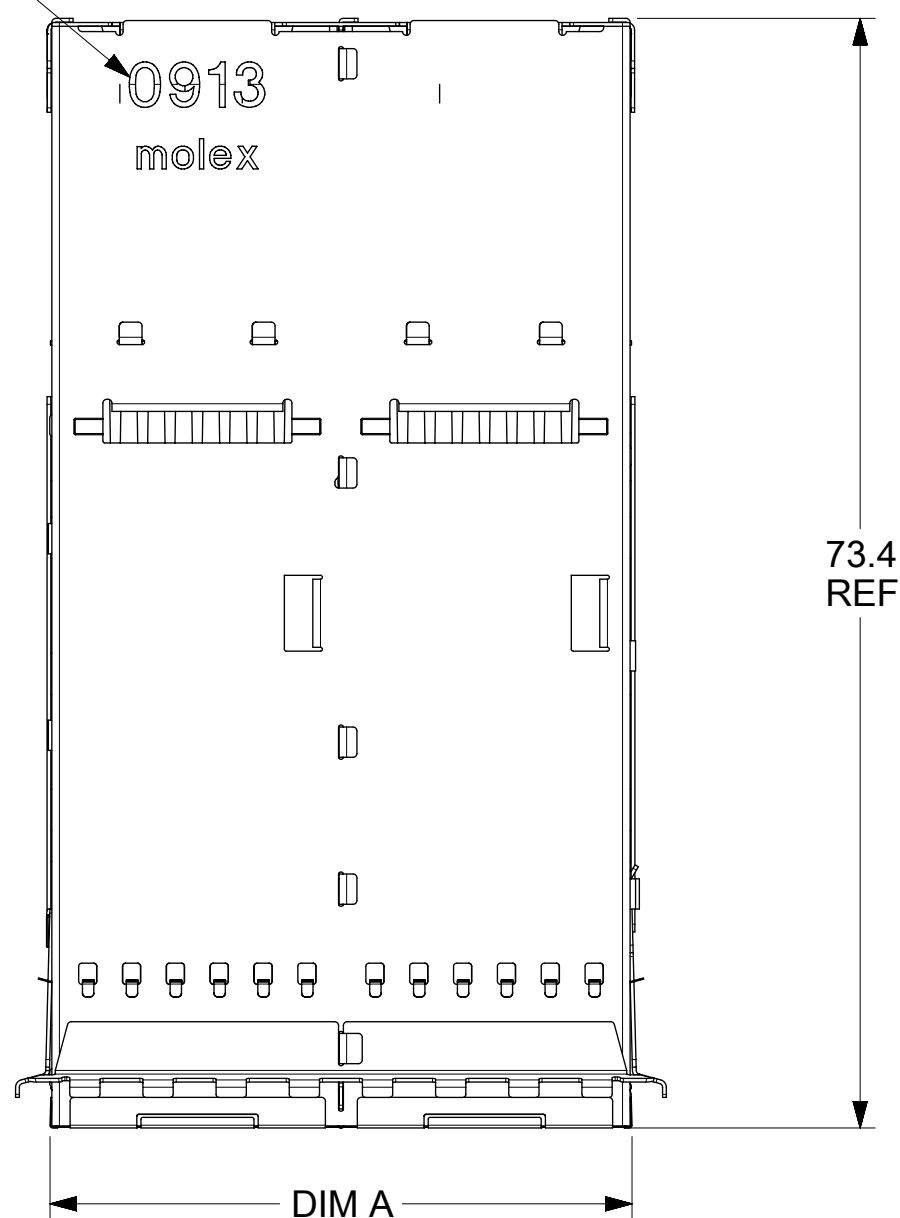

NOTES:

1. MATERIAL:
 CAGE: NICKEL SILVER, 0.25 THICK
 EMI STRAPS: PHOS-BRONZE, 0.10 THICK
 GASKET: SILICONE
 LIGHT PIPES (OPTIONAL): POLYCARBONATE
 (PER TELCORDIA-GR-63-CORE-ISSUE3, SECTION 4.2.3.1; R4-43,
 DISCRETE STRUCTURAL COMPONENTS CONSTITUTING A FUEL
 LOAD OF 1 GRAM OR LESS ARE EXEMPT FROM THE REQUIREMENTS
 OF R4-43 (91); UL 94V-0 RATING)
 CONNECTOR HOUSING: HIGH PERFORMANCE THERMOPLASTIC, 94V-0
 TERMINALS: HIGH PERFORMANCE COPPER ALLOY, 0.18 THICK
2. FINISH:
 SPRING FINGERS: 0.5µm NICKEL OVERALL
 GASKET: SILVER
 TERMINALS: CONTACT AREA: 0.76µm MIN GOLD OVER 2.5µm MIN NICKEL.
 COMPLIANT AREA: 0.76-1.52µm MATTE TIN OVER 1.27µm MIN NICKEL.
3. ALL SURFACES TO BE CLASS 'C' OR BETTER PER MOLEX COSMETIC SPECIFICATION PS-45499-002.
4. REFER TO PK-76871-9001 FOR ALL PACKAGING SPECIFICATIONS.
5. CONNECTOR INTENDED TO MATE WITH PLUG CABLE SERIES 74757 AND 74758.
6. DATE CODE LOCATION SHOWN, DATE CODE FORMAT: DDDY
 DDD = DAY OF THE YEAR, Y = YEAR.

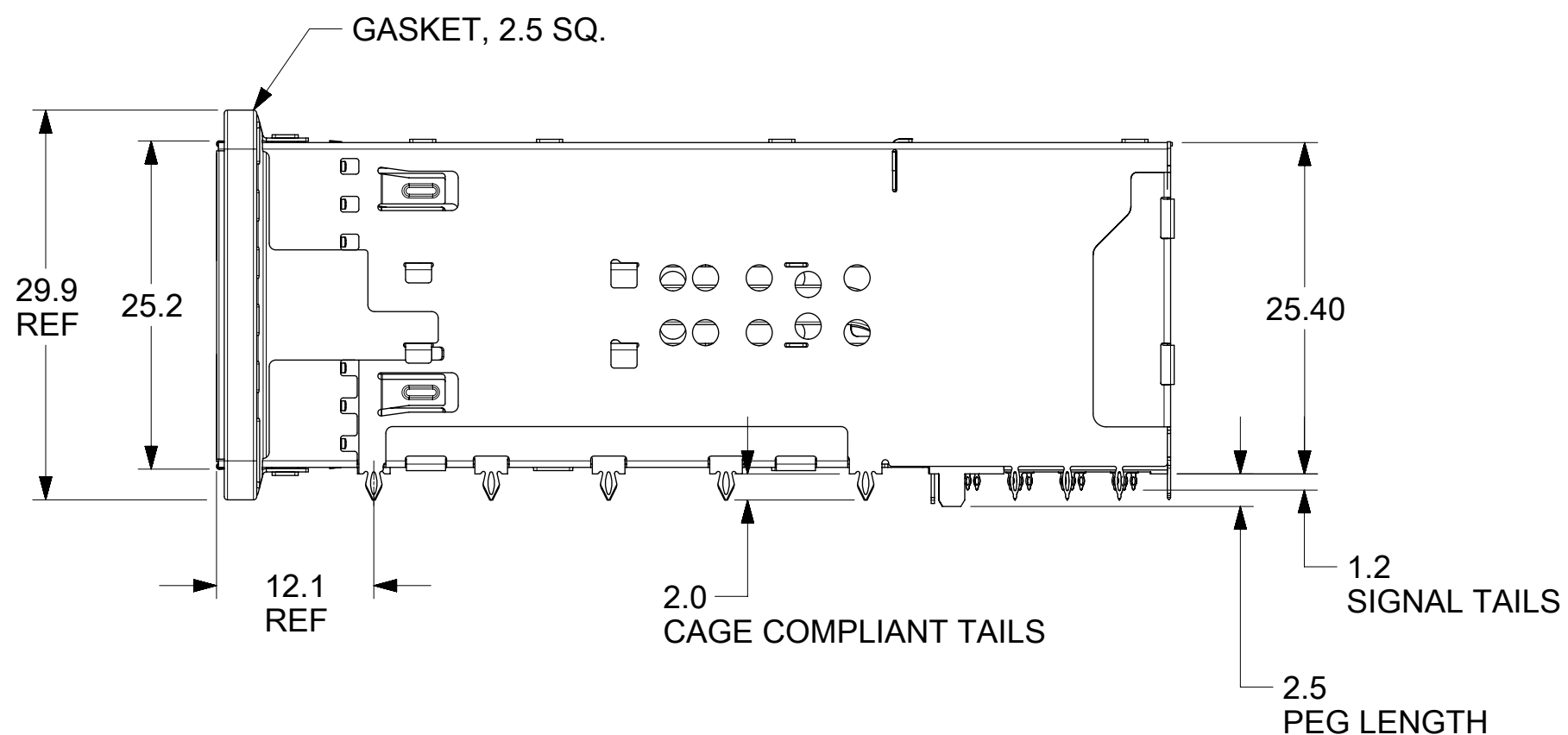
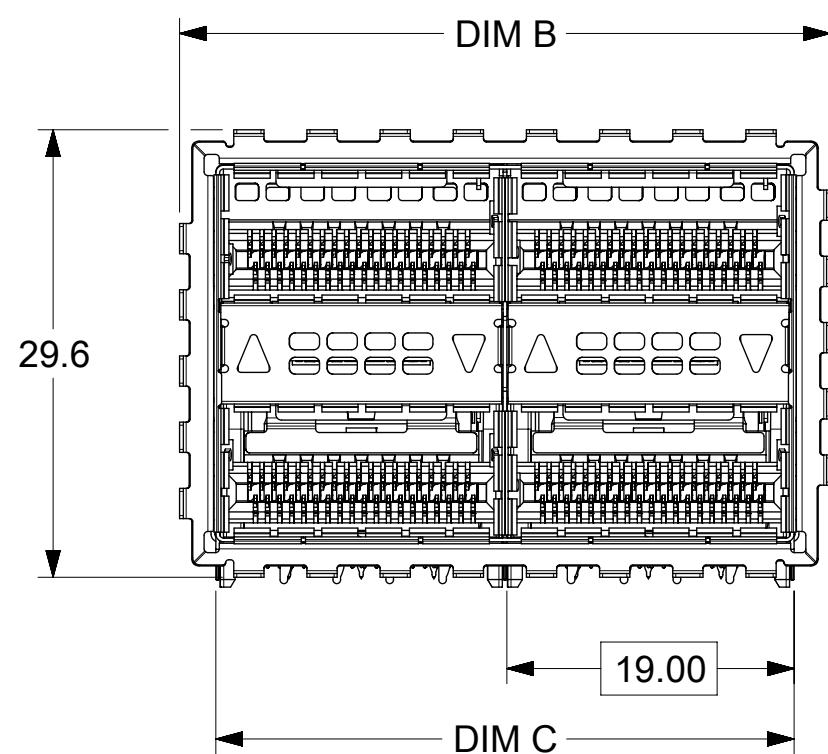

FRONT PLATE OPTIONS

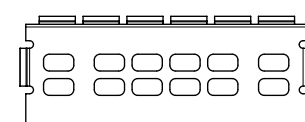

P/N 171565-*001
AIRFLOW ONLY
NO LIGHTPIPE

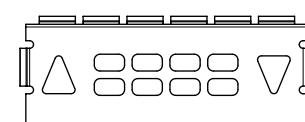

P/N 171565-*002
UP / DOWN LIGHTPIPE
INDICATOR

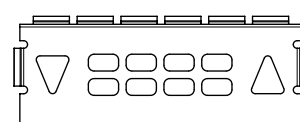

P/N 171565-*003
DOWN / UP LIGHTPIPE
INDICATOR

PORT SIZE	PART NUMBER	DIM 'A'	DIM 'B'	DIM 'C'
2X1	171565-100*	19.5	24.1	19.00
2X2	171565-000*	38.5	43.1	38.00
2X3	171565-300*	57.5	62.1	57.00

* - DESIGNATES FRONT PLATE OPTIONS

171565-000* SHOWN FOR REFERENCE
APPEARANCE MAY VARY BY SIZE

THIS DRAWING CONTAINS INFORMATION THAT IS PROPRIETARY TO MOLEX ELECTRONIC TECHNOLOGIES, LLC AND SHOULD NOT BE USED WITHOUT WRITTEN PERMISSION

DIMENSION UNITS	SCALE	CURRENT REV DESC:		molex
mm	2:1			
GENERAL TOLERANCES (UNLESS SPECIFIED)		EC NO: 176836		ZQSFP+ STACKED ASSY W/ELASTOMERIC GASKET
4 PLACES	±	DRWN: PKH	2018/05/21	
3 PLACES	±	CHK'D: SHONG	2018/05/30	
2 PLACES	± 0.13	APPR: SHONG	2018/05/30	PRODUCT CUSTOMER DRAWING
1 PLACE	± 0.25	INITIAL REVISION:		DOCUMENT NUMBER
0 PLACES	±	DRWN: JKACHLIC	2012/08/23	SD-171565-2000
ANGULAR TOL	± 0.5 °	APPR: MBANAKIS	2012/08/30	DOC TYPE
DRAFT WHERE APPLICABLE MUST REMAIN WITHIN DIMENSIONS	THIRD ANGLE PROJECTION	DRAWING	SERIES	DOC PART
		C-SIZE	171565	REVISION
				1 A1
		MATERIAL NUMBER	CUSTOMER	SHEET NUMBER
		SEE CHART	GENERAL MARKET	1 OF 3

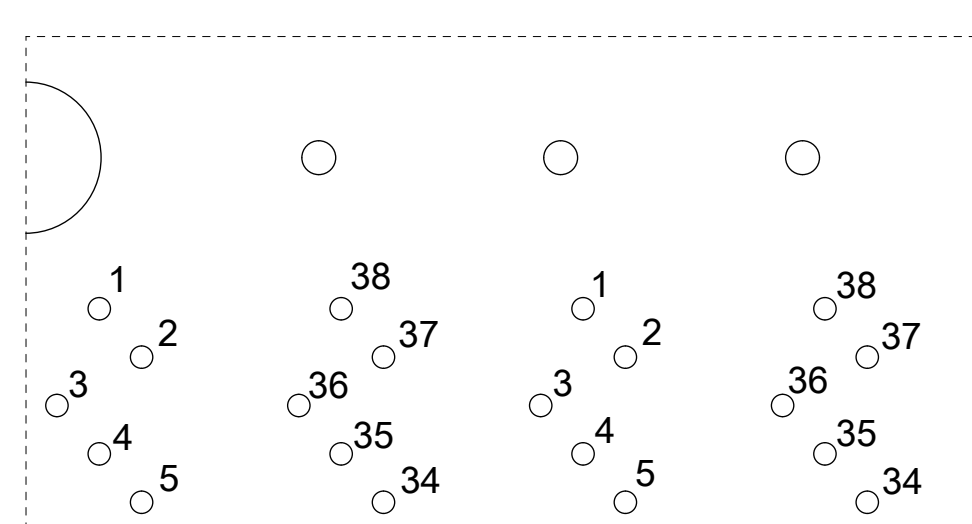
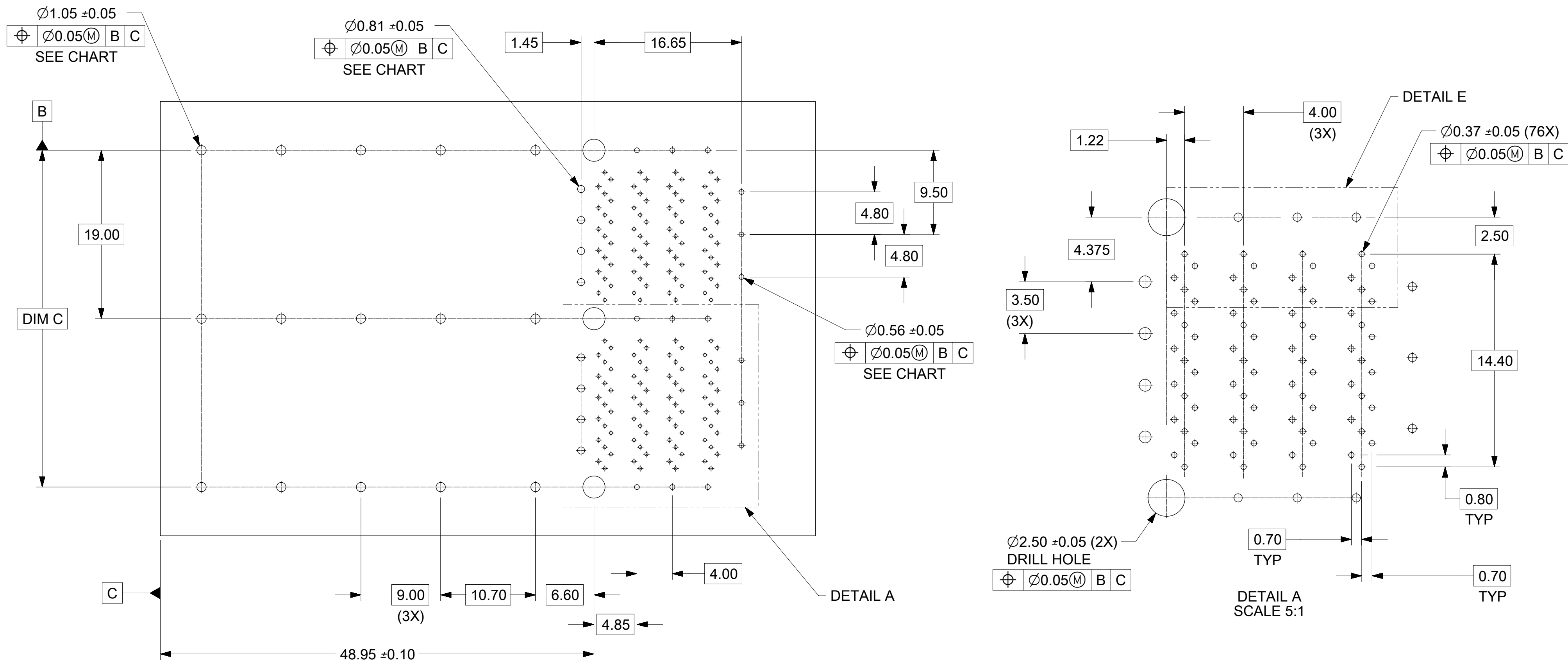

PORT SIZE	DIM C	Ø1.05 PTH QUANTITY	Ø0.56 PTH QUANTITY	Ø0.81 PTH QUANTITY
2X1	19.00	10	9	4
2X2	38.00	15	15	8
2X3	57.00	20	21	12

THIS DRAWING CONTAINS INFORMATION THAT IS PROPRIETARY TO MOLEX ELECTRONIC TECHNOLOGIES, LLC AND SHOULD NOT BE USED WITHOUT WRITTEN PERMISSION

DIMENSION UNITS mm	SCALE 3:1	CURRENT REV DESC:		molex
GENERAL TOLERANCES (UNLESS SPECIFIED)		EC NO: 176836	DRWN: PKH 2018/05/21	
4 PLACES ±	MM INCH	DRWN: SHONG	2018/05/30	PRODUCT CUSTOMER DRAWING
3 PLACES ±		APP: SHONG	2018/05/30	
2 PLACES ± 0.13		INITIAL REVISION:		DOCUMENT NUMBER
1 PLACE ± 0.25		DRWN: JKACHLIC	2012/08/23	SD-171565-2000
0 PLACES ±		APP: MBANAKIS	2012/08/30	DOC TYPE DOC PART REVISION
ANGULAR TOL ± 0.5°		THIRD ANGLE PROJECTION		PSD 001 A1
DRAFT WHERE APPLICABLE MUST REMAIN WITHIN DIMENSIONS		DRAWING	SERIES	MATERIAL NUMBER
		C-SIZE	171565	SEE CHART
				CUSTOMER
				GENERAL MARKET
				SHEET NUMBER
				2 OF 3

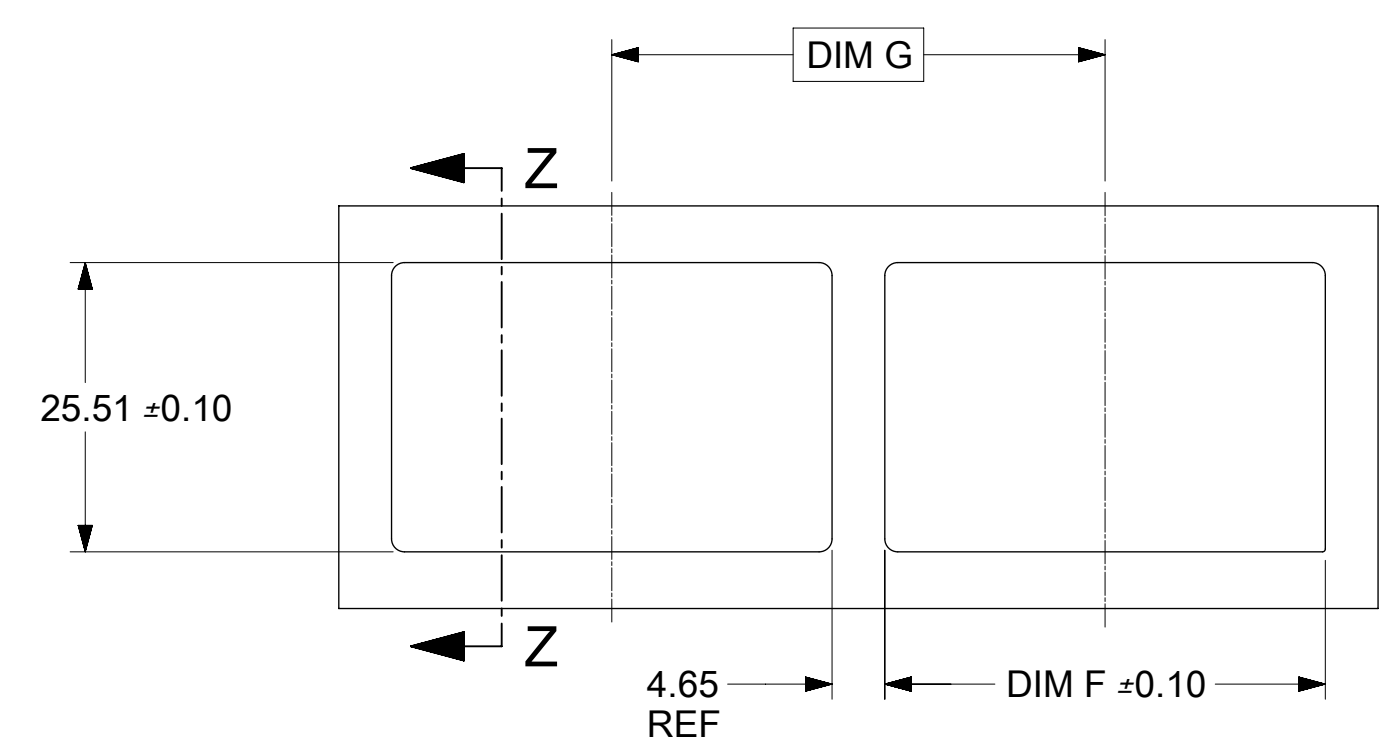
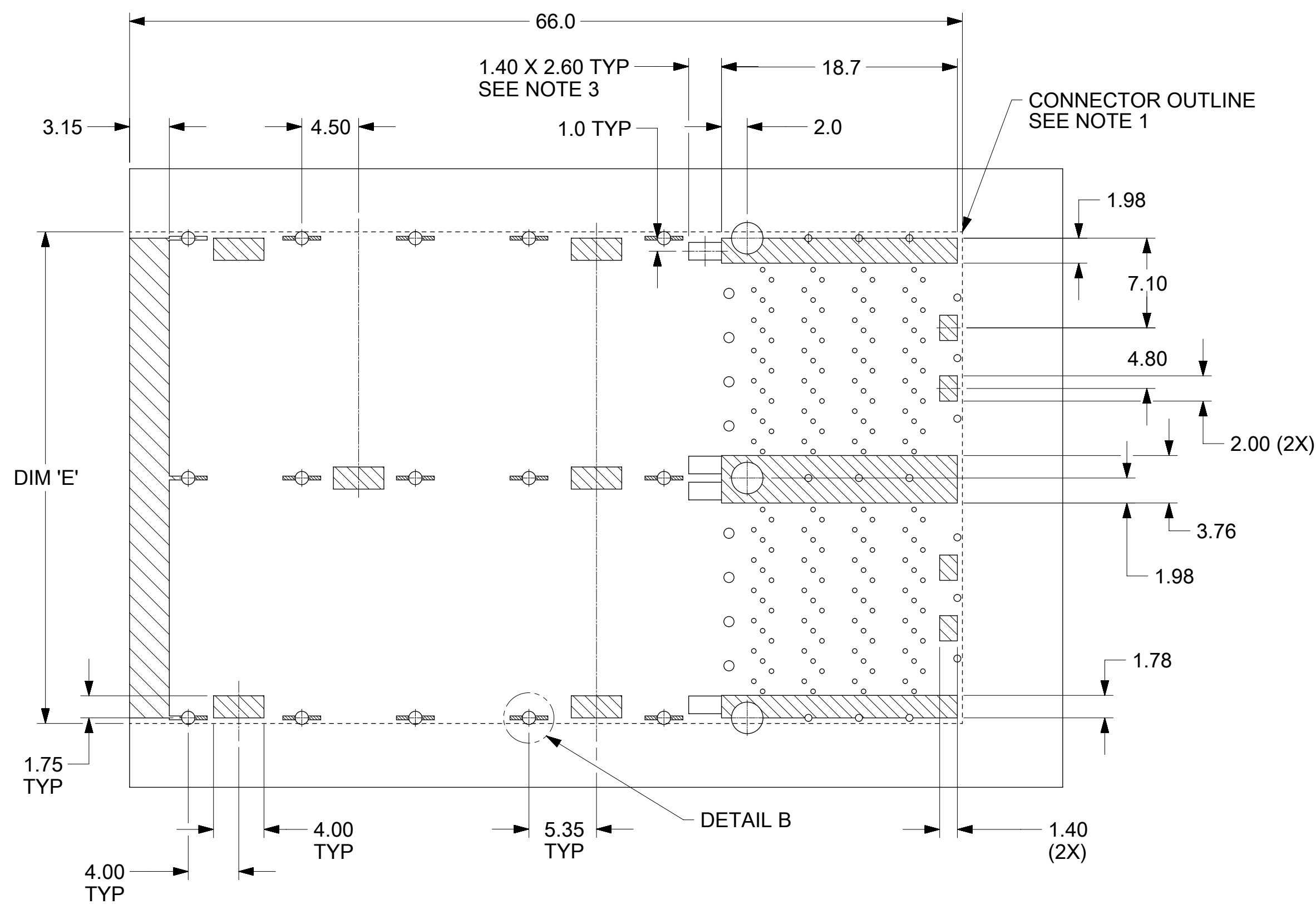

PANEL OPENING REQUIREMENTS

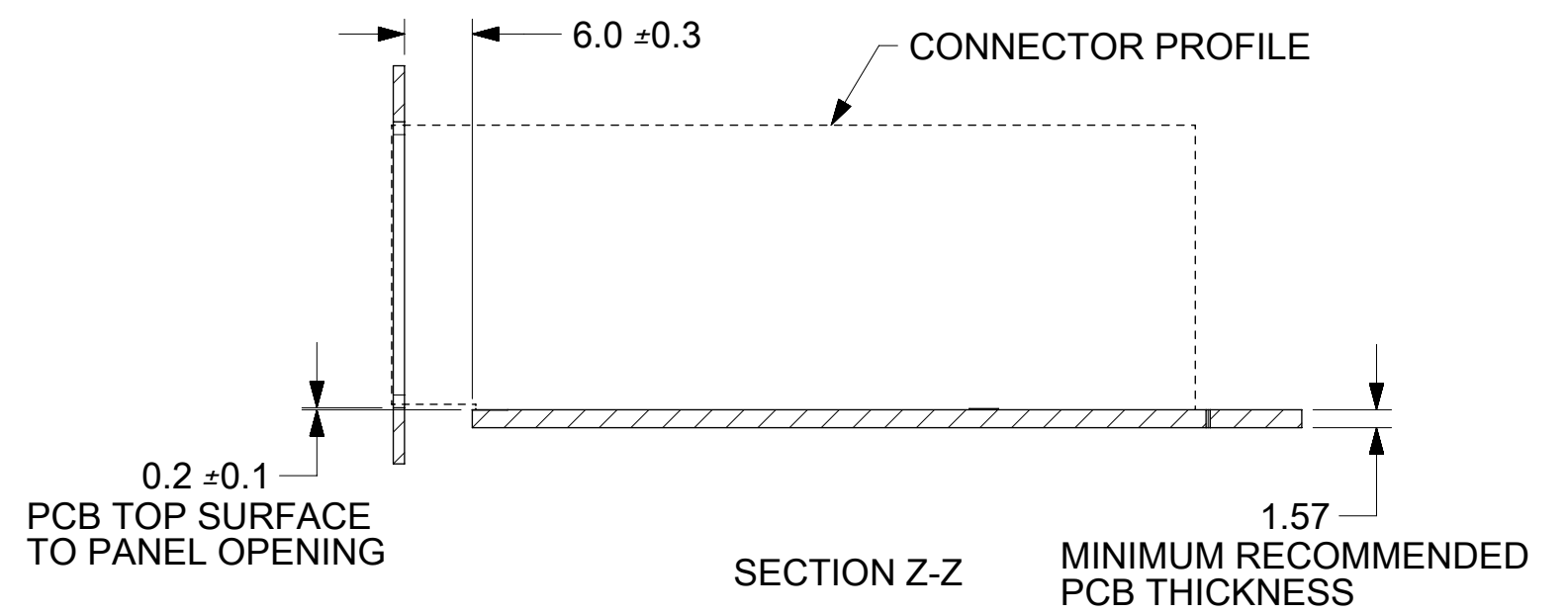

SECTION Z-Z MINIMUM RECOMMENDED PCB THICKNESS

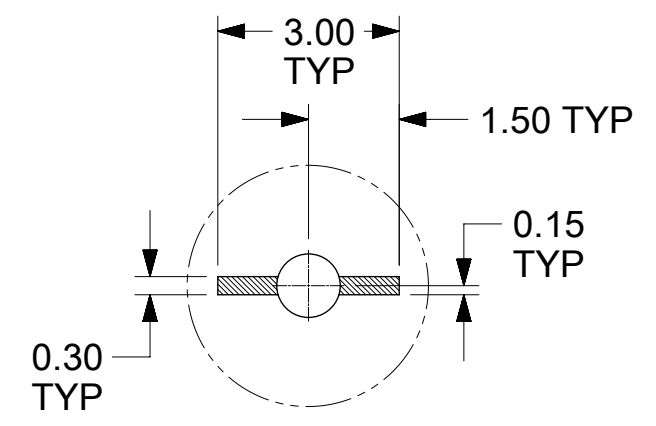

DETAIL B SCALE 8:1

PORT SIZE	DIM 'E'	DIM 'F'	DIM 'G'
2X1	19.5	19.85	24.50
2X2	38.5	38.85	43.50
2X3	57.5	57.85	62.50

- NOTES:
1. THE ENTIRE AREA UNDER THE CONNECTOR IS A COMPONENT KEEP-OUT ZONE.
 2. CROSS HATCHED AREAS INDICATE PLACES WHERE THE PLASTIC HOUSING AND METAL CAGE MAY BE IN CONTACT WITH THE PCB SURFACE. THESE AREAS ARE THE TRACE KEEP-OUT ZONES.
 3. THESE RECTANGULAR ZONES ARE FOR LED PLACEMENT. LED HEIGHT SHOULD NOT EXCEED 0.8 AND PLACEMENT SHOULD BE CENTERED WITHIN THIS LED KEEP-IN ZONE.
 4. RECOMMENDED LED CHIP PACKAGE SIZE IS 0805.

THIS DRAWING CONTAINS INFORMATION THAT IS PROPRIETARY TO MOLEX ELECTRONIC TECHNOLOGIES, LLC AND SHOULD NOT BE USED WITHOUT WRITTEN PERMISSION

DIMENSION UNITS	SCALE	CURRENT REV DESC:		molex				
mm	1:1							
GENERAL TOLERANCES (UNLESS SPECIFIED)		EC NO: 176836		ZQSFP+ STACKED ASSY W/ELASTOMERIC GASKET				
4 PLACES	±	DRWN: PKH	2018/05/21					
3 PLACES	±	CHK'D: SHONG	2018/05/30					
2 PLACES	± 0.13	APPR: SHONG	2018/05/30	PRODUCT CUSTOMER DRAWING				
1 PLACE	± 0.25	INITIAL REVISION:		DOCUMENT NUMBER				
0 PLACES	±	DRWN: JKACHLIC	2012/08/23	SD-171565-2000		DOC TYPE	DOC PART	REVISION
ANGULAR TOL ± 0.5°		APPR: MBANAKIS	2012/08/30			PSD	001	A1
DRAFT WHERE APPLICABLE MUST REMAIN WITHIN DIMENSIONS		THIRD ANGLE PROJECTION	DRAWING	SERIES	MATERIAL NUMBER	CUSTOMER	SHEET NUMBER	
			C-SIZE	171565	SEE CHART	GENERAL MARKET	3 OF 3	