

|               |     |              |            |            |     |        |        |                     |                    |               |
|---------------|-----|--------------|------------|------------|-----|--------|--------|---------------------|--------------------|---------------|
| MOLEX         |     |              |            | CUSTOMER   |     |        |        | DRAWING LOCATION    | CHANGE DESCRIPTION | AFFECTED DEPT |
| DRAWING NO.   | REV | ECN NO.      | DATA       | P/N        | P/N | 3D REV | 2D REV |                     |                    |               |
| SD-146220-050 | A   | ABU2016-0045 | 2015/11/17 | 1462200050 |     |        |        | NEW RELEASE         |                    |               |
| SD-146220-050 | B   | 111421       | 2016/12/19 | 1462200050 |     |        |        | CHANGE CAP MATERIAL |                    |               |

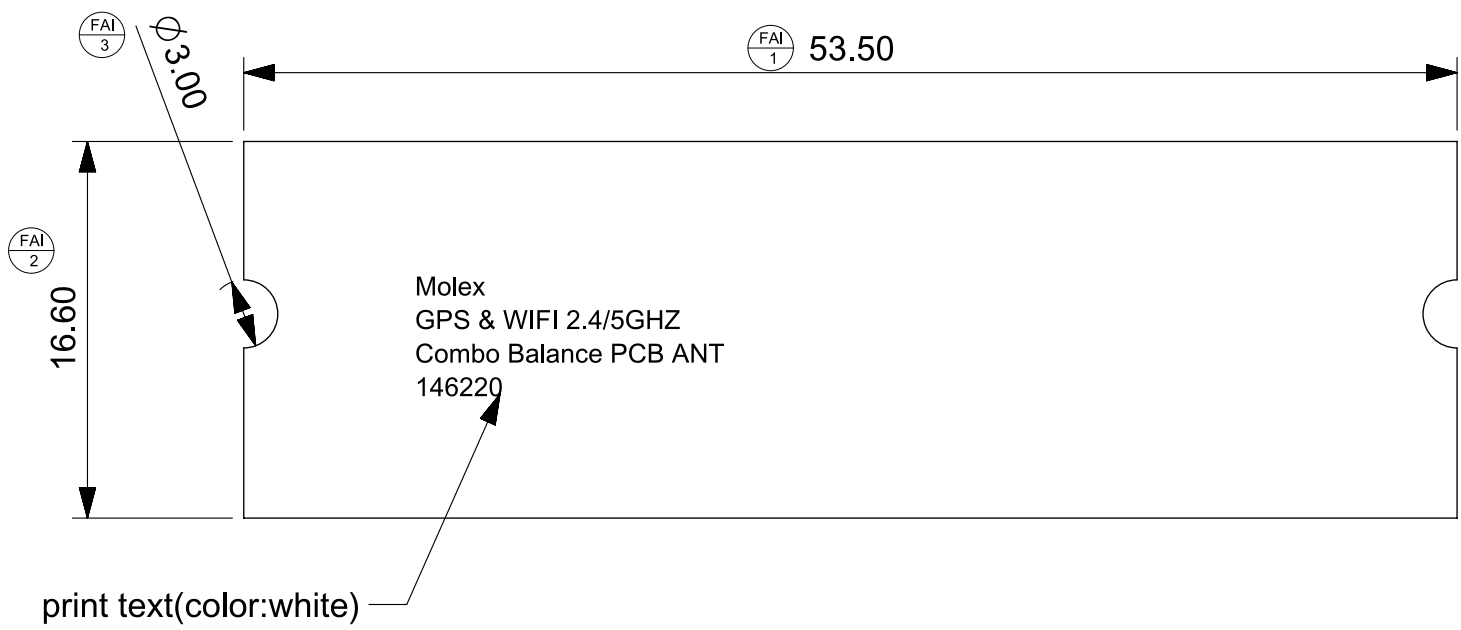

| ITEM | ASSY P/N   | DESCRIPTION       |
|------|------------|-------------------|
| 1    | 1462200050 | Flex +50mm Cable  |
| 2    | 1462200100 | Flex +100mm Cable |
| 3    | 1462200150 | Flex +150mm Cable |
| 4    | 1462200200 | Flex +200mm Cable |
| 5    | 1462200250 | Flex +250mm Cable |
| 6    | 1462200300 | Flex +300mm Cable |

NOTE:  
1.Material: PCB 53.5mm \* 16.6mm thickness 0.8mm  
Base Copper: 18~20um  
2.Tolerance on all copper artwork is +/-0.05mm.  
3.Tolerance on all die cutlines is +/-0.1mm.  
4.Tolerance between artwork and die cutline is +/-0.25mm.Others: +/-0.2mm  
5.Ni&Au plating in the solder pad area:  
Ni: 2-6 um, Au: min. 0.025 um thickness  
6.Solder Mask: Green

|                                                                                                                               |          |                                                      |                                       |                 |                        |                                          |                |          |              |
|-------------------------------------------------------------------------------------------------------------------------------|----------|------------------------------------------------------|---------------------------------------|-----------------|------------------------|------------------------------------------|----------------|----------|--------------|
| THIS DRAWING CONTAINS INFORMATION THAT IS PROPRIETARY TO MOLEX INCORPORATED AND SHOULD NOT BE USED WITHOUT WRITTEN PERMISSION |          |                                                      |                                       |                 |                        |                                          |                |          |              |
| EC DESCRIPTION<br>EC NO: 111421<br>DRWN: ZLRAO<br>CHK'D: Chris Yu<br>APPR: Welson Tan                                         | 19/12/16 | QUALITY SYMBOLS                                      | GENERAL TOLERANCES (UNLESS SPECIFIED) | DIMENSION UNITS | SCALE                  | <b>molex</b>                             |                |          |              |
|                                                                                                                               | 19/12/16 | ▽ = 0                                                | ANGULAR TOL ± 1/2 °                   | mm              | 5:1                    |                                          |                |          |              |
|                                                                                                                               | 19/12/16 | ▽ = 0                                                | 4 PLACES ± 0.00000                    | DRWN BY         | DATE                   | GPS & WIFI 2.4/5GHZ BALANCE ANTENNA_ASSY |                |          |              |
|                                                                                                                               | 19/12/16 | ▽ = 0                                                | 3 PLACES ± 0.00000                    | ZLRAO           | 2016/12/19             |                                          |                |          |              |
|                                                                                                                               | 19/12/16 | ▽ = 0                                                | 2 PLACES ± 0.00000                    | CHK'D BY        | DATE                   | PRODUCT DESIGN DRAWING                   |                |          |              |
| 19/12/16                                                                                                                      | ▽ = 0    | 1 PLACE ± 0.00000                                    | Chris Yu                              | 2016/12/19      |                        |                                          |                |          |              |
| 19/12/16                                                                                                                      | ▽ = 0    | 0 PLACES ± 0.00000                                   | APPR BY                               | DATE            | SERIES                 | MATERIAL NUMBER                          | CUSTOMER       |          |              |
| 19/12/16                                                                                                                      | ▽ = 0    |                                                      | Welson Tan                            | 2016/12/19      | 146220                 | See Table                                | GENERAL MARKET |          |              |
| B                                                                                                                             | REV      | DRAFT WHERE APPLICABLE MUST REMAIN WITHIN DIMENSIONS |                                       | DRAWING SIZE    | THIRD ANGLE PROJECTION | DOCUMENT NUMBER                          | DOC TYPE       | DOC PART | SHEET NUMBER |
|                                                                                                                               |          |                                                      |                                       | A3              |                        | SD-146220-050                            | XXX            | XXX      | 1 OF 2       |

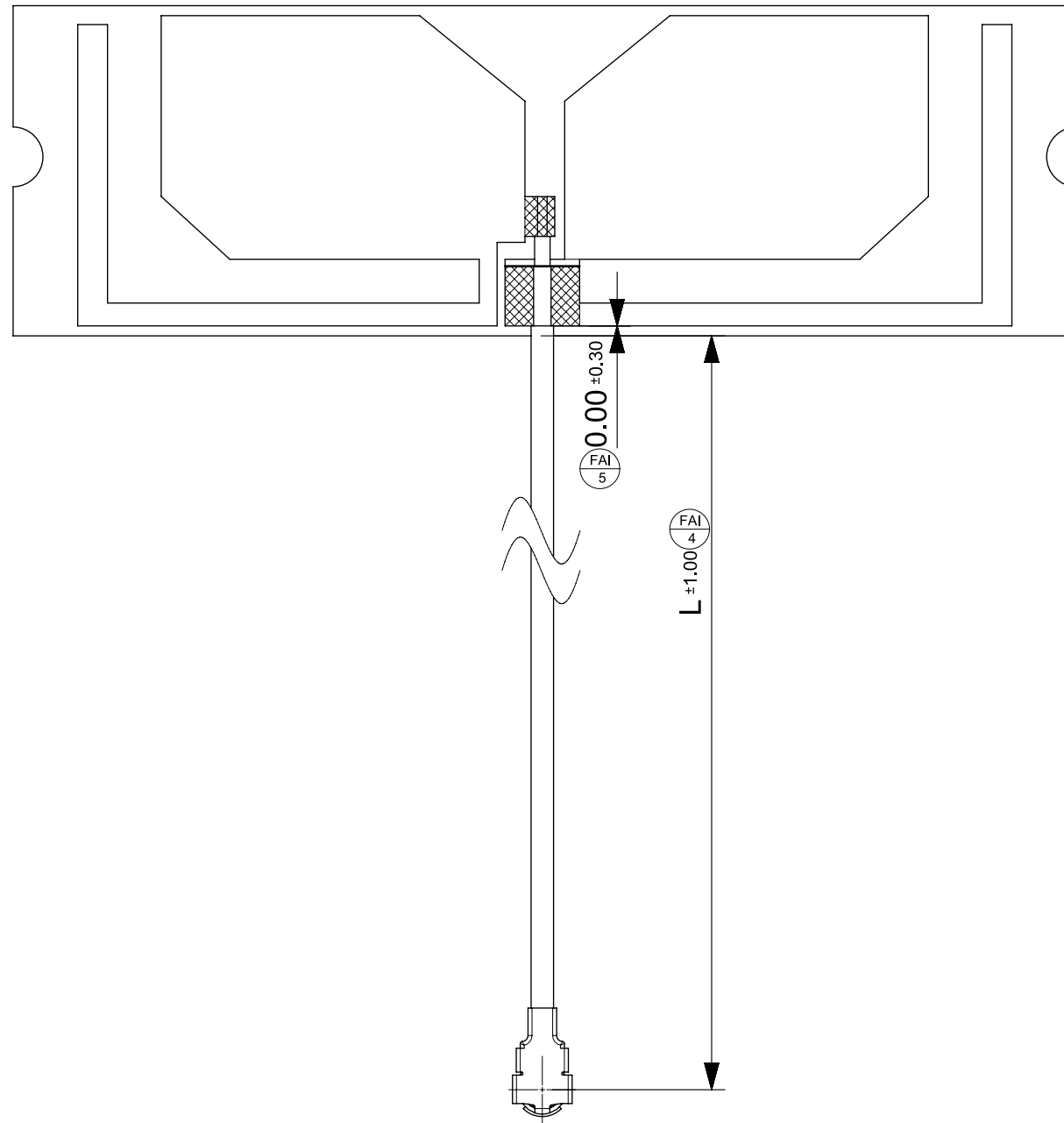

| ITEM | CABLE TYPE  | CABLE LENGTH "L" |
|------|-------------|------------------|
| 1    | CABLE 50MM  | 43MM             |
| 2    | CABLE 100MM | 93MM             |
| 3    | CABLE 150MM | 143MM            |
| 4    | CABLE 200MM | 193MM            |
| 5    | CABLE 250MM | 243MM            |
| 6    | CABLE 300MM | 293MM            |

**NOTE:**

- 1.The dimesndion with tolerance in box should be controlled by flex supplier and tolerance of other dimension  $\pm 0.2\text{mm}$
- 2.The cable line can not be rotated with the weld point for more than 60 degrees.
3. For pull test, can not lift up in the vertical direction
- 4.After RF test, please use the cap to protection connector, the cap material:Silica Gel,type:FP EC3.0-10(0.8)

| THIS DRAWING CONTAINS INFORMATION THAT IS PROPRIETARY TO MOLEX INCORPORATED AND SHOULD NOT BE USED WITHOUT WRITTEN PERMISSION |                                  |                                                                          |                                                                                                                                                      |                                                                                          |       |              |  |  |  |  |  |
|-------------------------------------------------------------------------------------------------------------------------------|----------------------------------|--------------------------------------------------------------------------|------------------------------------------------------------------------------------------------------------------------------------------------------|------------------------------------------------------------------------------------------|-------|--------------|--|--|--|--|--|
| EC DESCRIPTION<br>EC NO: 111421<br>DRWN: ZLRAO<br>CHK'D: Chris Yu<br>APPR: Welson Tan                                         | 19/12/16<br>19/12/16<br>19/12/16 | QUALITY SYMBOLS                                                          | GENERAL TOLERANCES (UNLESS SPECIFIED)                                                                                                                | DIMENSION UNITS                                                                          | SCALE | <b>molex</b> |  |  |  |  |  |
|                                                                                                                               |                                  | $\nabla = 0$<br>$\nabla = 0$<br>$\nabla = 0$                             | ANGULAR TOL $\pm 1/2^\circ$<br>4 PLACES $\pm 0.00000$<br>3 PLACES $\pm 0.00000$<br>2 PLACES $\pm 0.000$<br>1 PLACE $\pm 0.00$<br>0 PLACES $\pm 0.00$ | mm                                                                                       | 4:1   |              |  |  |  |  |  |
|                                                                                                                               |                                  | DRWN BY                                                                  | DATE                                                                                                                                                 | GPS & WIFI 2.4/5GHZ BALANCE ANTENNA_ASSY                                                 |       |              |  |  |  |  |  |
|                                                                                                                               |                                  | ZLRAO                                                                    | 2016/12/19                                                                                                                                           |                                                                                          |       |              |  |  |  |  |  |
|                                                                                                                               |                                  | CHK'D BY                                                                 | DATE                                                                                                                                                 | PRODUCT DESIGN DRAWING                                                                   |       |              |  |  |  |  |  |
|                                                                                                                               |                                  | Chris Yu                                                                 | 2016/12/19                                                                                                                                           |                                                                                          |       |              |  |  |  |  |  |
| APPR BY                                                                                                                       | DATE                             | SERIES: 146220    MATERIAL NUMBER: See Table    CUSTOMER: GENERAL MARKET |                                                                                                                                                      |                                                                                          |       |              |  |  |  |  |  |
| Welson Tan                                                                                                                    | 2016/12/19                       |                                                                          |                                                                                                                                                      |                                                                                          |       |              |  |  |  |  |  |
| DRAFT WHERE APPLICABLE MUST REMAIN WITHIN DIMENSIONS                                                                          |                                  | DRAWING SIZE                                                             | THIRD ANGLE PROJECTION                                                                                                                               | DOCUMENT NUMBER: SD-146220-050    DOC TYPE: XXX    DOC PART: XXX    SHEET NUMBER: 2 OF 2 |       |              |  |  |  |  |  |
|                                                                                                                               |                                  | A3                                                                       |                                                                                                                                                      |                                                                                          |       |              |  |  |  |  |  |