

Jul.1.2024 Copyright 2024 HIROSE ELECTRIC CO., LTD. All Rights Reserved.  
 In case of consideration for using Automotive equipment / device which demand high reliability, kindly contact our sales window correspondents.

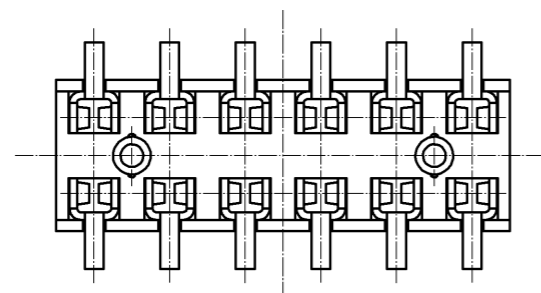

RECOMMENDED LAND PATTERN DIMENSION OF PCB (MOUNTING SIDE)  
 (RECOMMENDED METAL MASK THICKNESS:0.2mm)

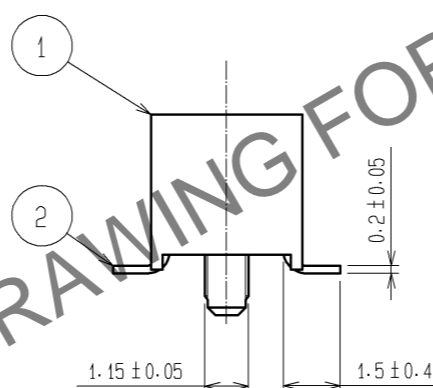
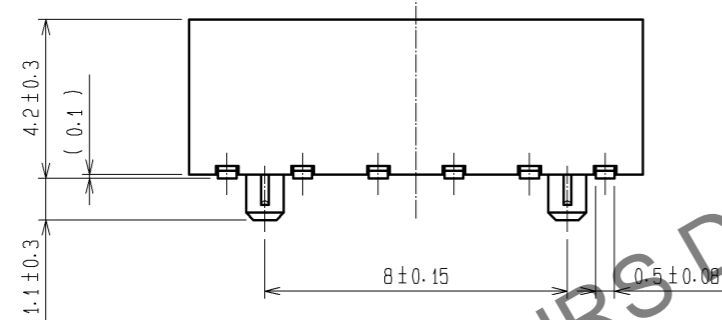
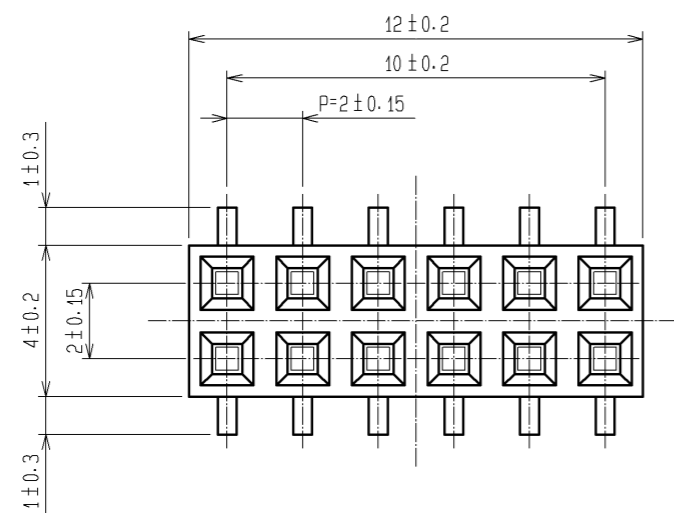
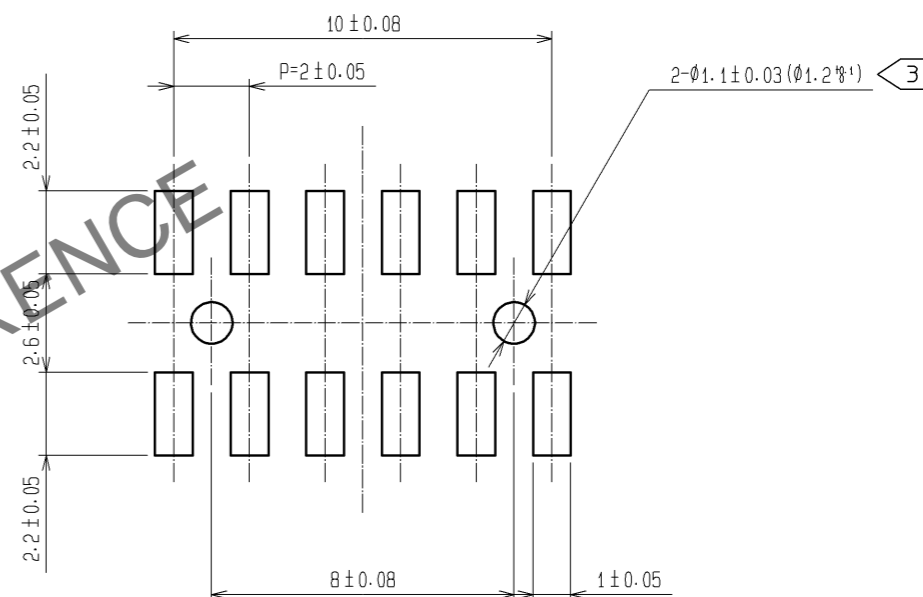

NOTE 1 LEAD CO-PLANARITY SHALL BE 0.15 MAX.  
 2 THE DIMENSIONS IN PARENTHESES ARE FOR REFERENCE.  
 3 FOR AUTOMATED MOUNTING, RECOMMENDED THROUGH HOLE DIAMETER OF BOSS IS 1.2±0.1.

1	PPS	LIGHT BROWN / UL94V-0	2	PHOSPHOR BRONZE	CONTACT AREA:GOLD 0.2µm min. LEAD AREA:TIN-PLATING 1µm min. UNDER PLATING:NICKEL 1µm min.		
NO.	MATERIAL	FINISH . REMARKS	NO.	MATERIAL	FINISH . REMARKS		
UNITS mm		SCALE 5 : 1	COUNT △	DESCRIPTION OF REVISIONS	DESIGNED	CHECKED	DATE
<b>HRS</b> HIROSE ELECTRIC CO., LTD.		APPROVED : HS. OKAWA	08.08.01	DRAWING NO.	EDC3-082677-21		
		CHECKED : HT. YAMAGUCHI	08.08.01	PART NO.	A3A-12DA-2SV(71)		
		DESIGNED : SY. KAMIGA	08.08.01	CODE NO.	CL621-1144-6-71		
		DRAWN : HK. SUNADORI	08.07.31		△ 1/1		