

Introduction

The EV42P34A evaluation board is based on Microchip's PD77728 PoE manager and the PD77020 PoE controller. The EV42P34A demonstrates eight IEEE® 802.3bt 4-pair ports using the PD77728 and PD77020 in Controller Mode

The PD77728 device is a part of the seventh generation IEEE 802.3bt compliant Power over Ethernet (PoE) Power Sourcing Equipment (PSE) family from Microchip. This device is a fully integrated eight port PoE controller and PoE manager, with integrated Field Effect Transistor (FET) switches and current sense resistors. The PD77728 chipset supports IEEE 802.3af/at/bt standards, as well as legacy/pre-standard PD detection. The device is available in a 56-pin, 8 mm × 8 mm Quad flat no-lead (QFN) package.

The Evaluation Board (EVB) includes two, dedicated, bi-color (green and yellow) LEDs per each port. These LEDs provide the visual status of each port.

The following figure shows the top view of the evaluation board.

Figure 1. Evaluation Board - Top View

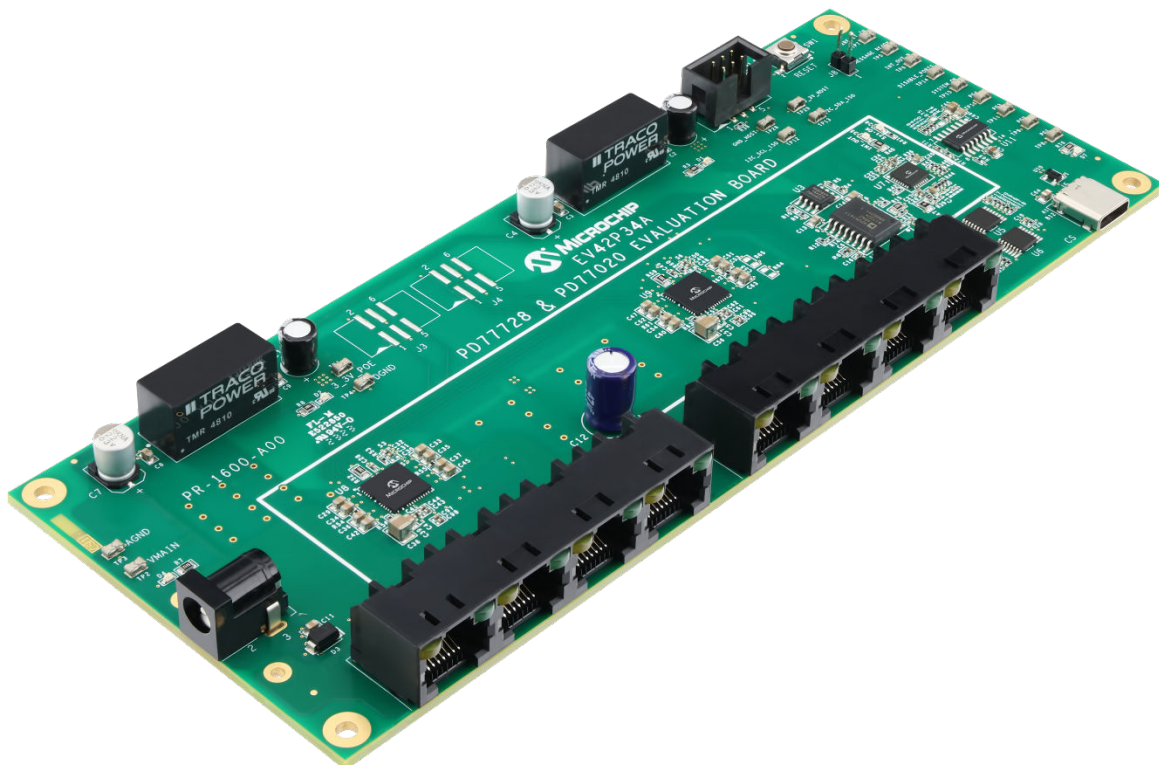

Features

The evaluation board has the following features.

- RJ45 Gang (Contains Eight RJ45 Connectors)
- Eight 4-pair ports structured by two PD77728 devices and controlled by the PD77020
- Switch Domain USB-C Interface to be connected to a PC with the Microchip GUI
- Manual Reset and Disable Port jumper
- Green And Yellow Bi-Color LED Status Indication for all eight ports
- Requires only a single power source
- 0 °C to 40 °C Operating Temperature
- RoHS Compliant

The following images show the system block diagram and the dimensions of the evaluation board.

Figure 2. EV42P34A Evaluation Board Block Diagram

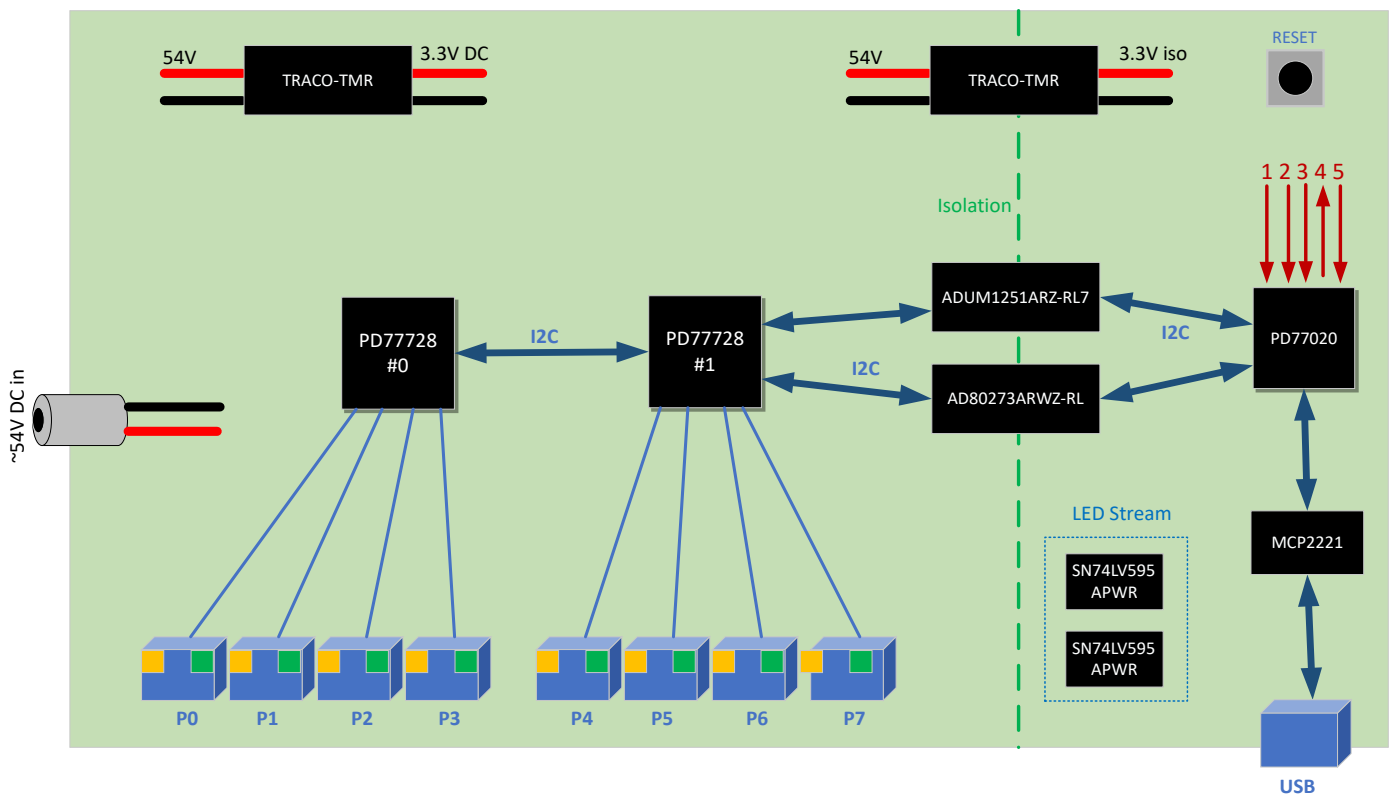
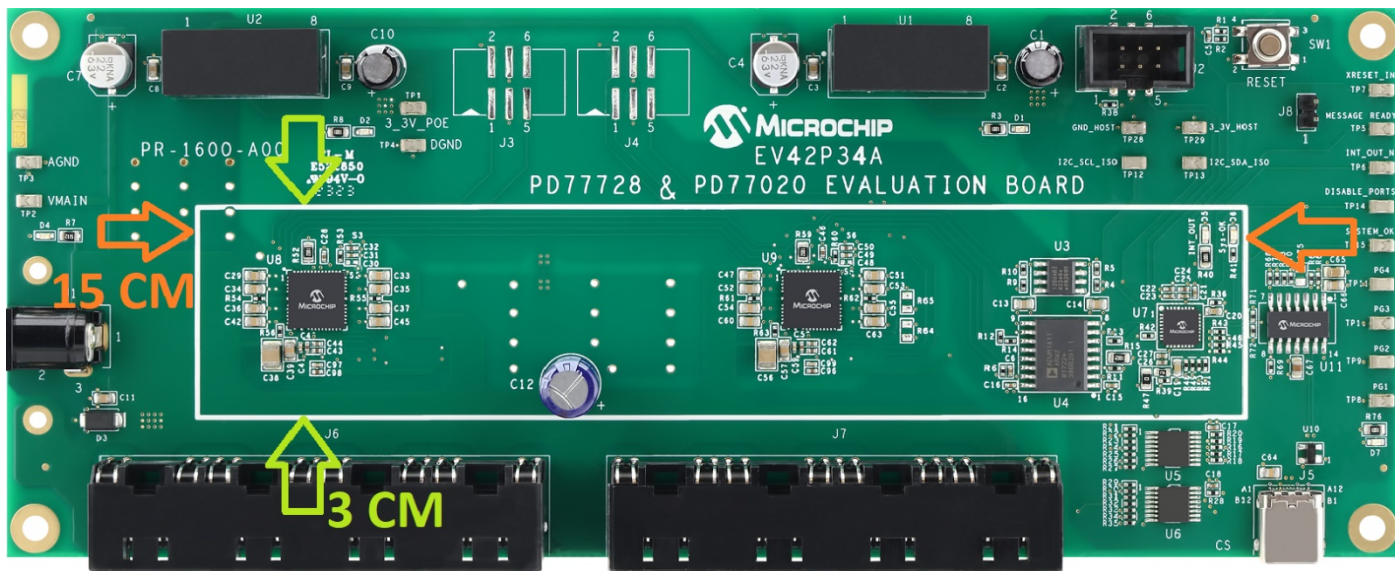

Figure 3. EV42P34A Dimension



Note: Actual PoE application size is 15 cm × 3 cm

Table of Contents

Introduction.....	1
Features.....	2
1. Overview.....	5
1.1. Power.....	5
1.2. Interface and Control.....	6
1.3. LED Indication.....	11
1.4. RJ45 Connectors Polarity.....	11
2. Installation and Setting.....	12
2.1. Schematics.....	12
3. Revision History.....	13
Microchip Information.....	14
The Microchip Website.....	14
Product Change Notification Service.....	14
Customer Support.....	14
Microchip Devices Code Protection Feature.....	14
Legal Notice.....	14
Trademarks.....	15
Quality Management System.....	16
Worldwide Sales and Service.....	17

1. Overview

This section provides the basic overview of the EV42P34A Evaluation board.

1.1 Power

The EVB is powered by a single source through the DC connector J1. The input voltage level can be selected according to the following IEEE 802.3 PoE standards:

1. IEEE 802.3af: 44 V_{DC} to 57 V_{DC}
2. IEEE 802.3at: 50 V_{DC} to 57 V_{DC}
3. IEEE 802.3bt:
 - a. 50 V_{DC} to 57 V_{DC} for type 3
 - b. 52 V_{DC} to 57 V_{DC} for type 4

The recommended voltage level is 53 V_{DC} to 55 V_{DC}, which covers all the PoE standards. The EVB has three power domains as follows:

1. PoE domain, which is fed directly by the main supply and is the power domain provided by the RJ45
2. 3.3 V_{DC} which feeds the PD77728 and serial communication peripherals, same ground as the PoE domain. That 3.3 V_{DC} is generated by U2 (a DC/DC module).
3. Isolated 3.3 V_{DC} for the PD77020, LED stream, and for the USB port; this power is provided by U1.

Note: The EVB is polarity sensitive. The correct polarity is shown in the following figure.

Figure 1-1. DC Connector J1 Polarity



Important: DC input connector J1 is limited to current level up to 4A. If higher current is needed, the 2 via holes next to J1 can be used, by soldering a cable to it. The two via holes support up to 8A to feed the whole EVB at full power.

The via holes are marked in the following figure; hole marked red is the V_{main} (+), and the hole marked black is the AGND (-).

Figure 1-2. Power via Holes

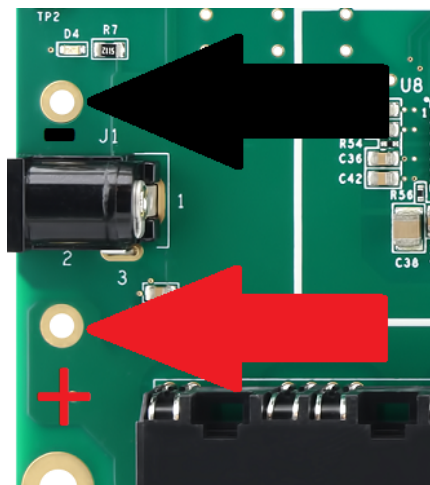

1.2 Interface and Control

This section describes the set-up procedures for serial communication, reset push-button, Over Supply Shutdown (OSS), PoE ports disable, power good input (PGD1–PGD4), and additional test points.

1.2.1 Serial Communication

The EVB supports serial communication with the PD77020 by I²C. The serial communication is converted to USB by the Microchip MCP2221A (U11) to allow a user-friendly experience using the Microchip dedicated GUI.

To use the USB port, install the MCP2221A driver on your PC. The driver can be downloaded from the Microchip website at www.microchip.com/wwwproducts/en/MCP2221A

If R75 is installed as 0Ω, the USB converter (U11) is disabled, which allows the user to connect directly to the I²C bus through the I²C pins of U11, and control the EVB through I²C. The DGND test-point is the GND for the I²C bus.

For test points location, see figure [Figure 1-7](#).

The EVB is set to I²C address 0x4 (R37=147K).

In order to select the I²C address, R37 should be installed according to the following table.

Table 1-1. I²C Address Select

I ² C Address	Address (Hex)	R37 (kΩ)
#1	0x4	147
#2	0x8	86.6
#3	0xC	57.6
#4	0x10	43.2
#5	0x14	34
#6	0x18	26.7
#7	0x1C	22.1
#8	0x20	18.2
#9	0x24	15.4
#10	0x28	13

.....continued

I ² C Address	Address (Hex)	R37 (kΩ)
#11	0x2C	11
#12	0x30	9.31
#13	0x34	7.87
#14	0x38	6.49
#15	0x3C	5.49

The following diagram shows the I²C address setting for the PD77020 controller.

Figure 1-3. I²C Address Setting Diagram

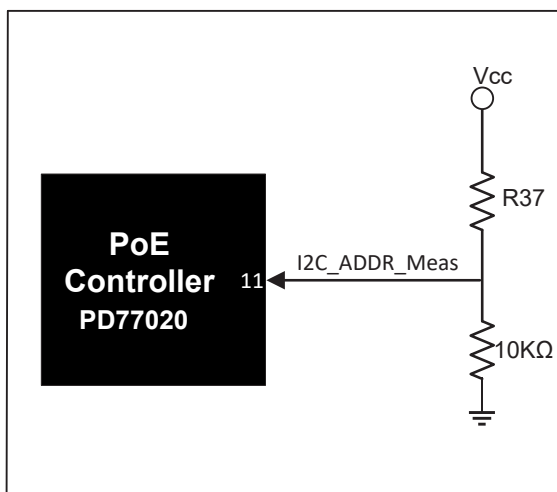

1.2.2 Reset Pushbutton

The pushbutton is connected to the Reset pin of the PD77020 (pin 26), as shown in the following figure. Pressing the SW1 switch connects the Reset pin to GND, and resets the PoE system.

Figure 1-4. Reset Control Diagram

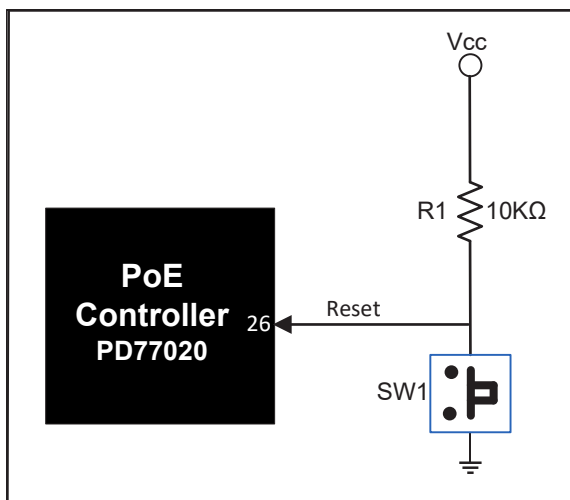

1.2.3 Over Supply Shutdown (OSS)

OSS is used to shut down ports based on the priority settings. The following figure shows the OSS control diagram.

Figure 1-5. OSS Control Diagram

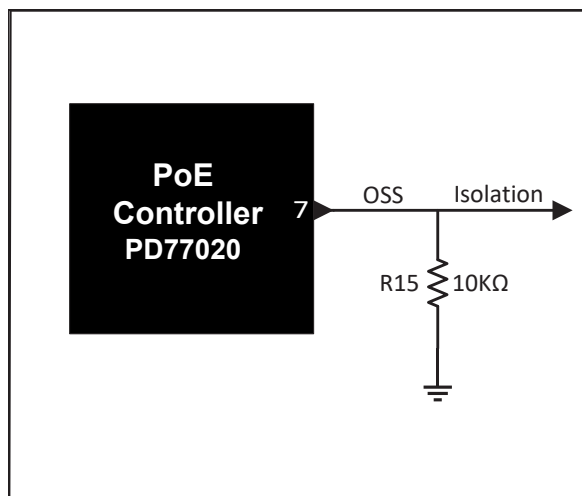

1.2.4 PoE Ports Disable Settings

The jumper J8 is connected to the Disable pin of the PD77020 (Pin 24). When the jumper J8 is installed, the Disable pin is connected to GND.

In normal operations, the host can disable all ports by setting this pin to '0'.

The following figure shows the J8 jumper settings.

Figure 1-6. Ports Disable Control Jumper Diagram

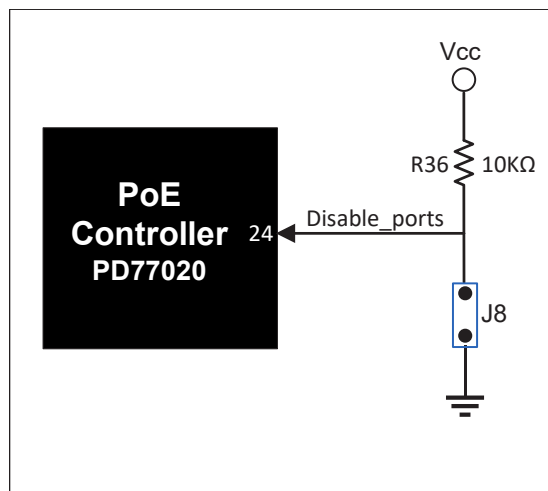

The following figure shows the J8 jumper port and the I²C bus and GND_HOST test points on the evaluation board.

Figure 1-7. I²C Bus and GND_HOST Test Points

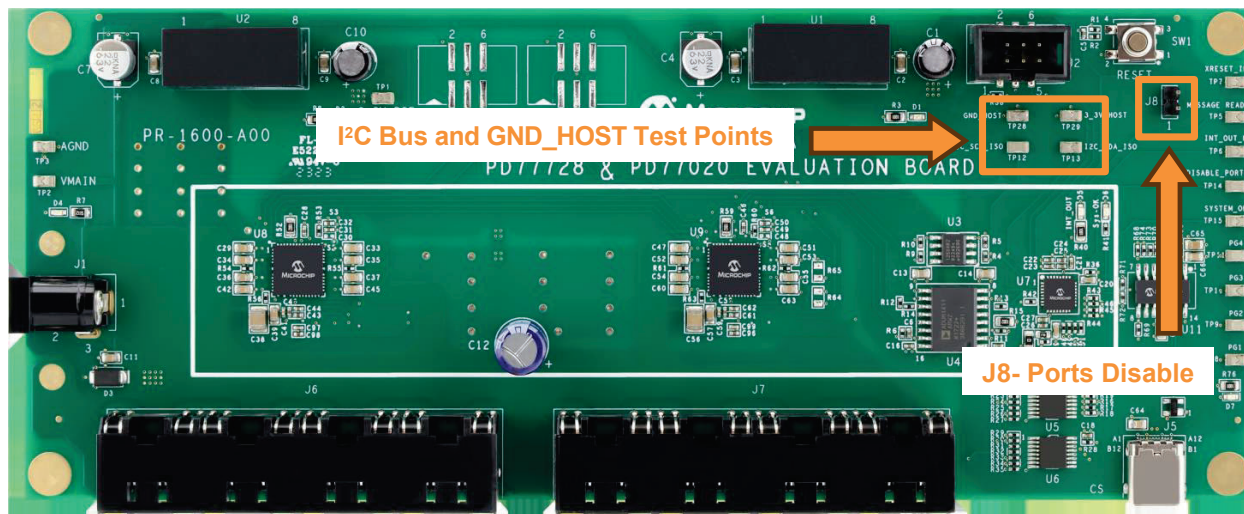

Important: These I²C test points are connected to the I²C bus, which connects the PD77020 to the two PD7728 devices.

1.2.5 Power Good Input (PGD) Settings

The EVB supports feeding from up to four power supplies, which includes 16 power banks (bank0 to bank15). Each power supply must generate a digital signal (0-3.3 V_{DC}), which indicates the power supply is active. The generated digital signal must be connected to one of the PGD pins of PD77020 (pins 17, 18, 19, and 20).

On the EVB, four PGD pins are pulled down with a 10K resistor to GND_HOST, which sets the default power bank to 0x00. To set a different bank than 0x00, the user can use the PG1-PG4 test points, located next to U11.

The four PG signals are referenced to the PD77020 domain (GND_HOST), see the following figures.

Figure 1-8. PG1-PG4 Test Points Diagram

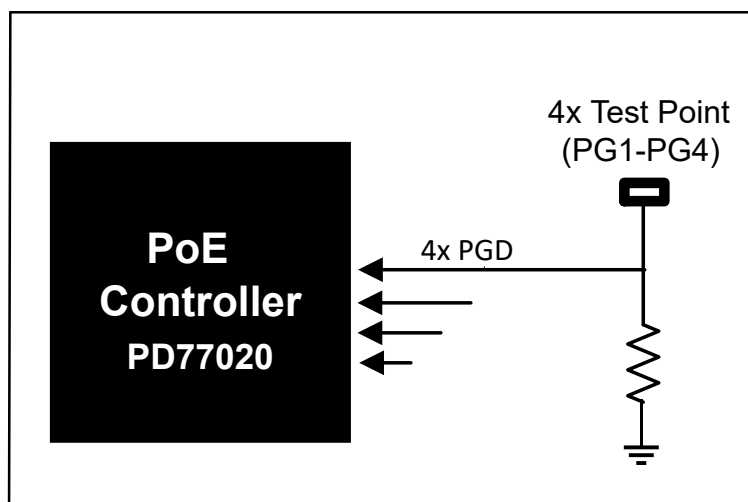

Figure 1-9. PG1–PG4 Test Points



1.2.6 Additional Test Points

The additional test points and their uses are listed below:

1. xI2C_Message_Ready (TP5): I²C message ready for reading by the host. Controller asserts this line low when it has an answer to the host. Therefore, the host can poll this line and initiate I2C read cycle only when the message is ready. After the host reads the data from the controller, this pin is asserted to high. (Active Low).
2. xINT_OUT (TP6): Interrupt output indication. This line is asserted Low when a pre-configured event is in progress. (Active Low).
3. xReset_IN (TP7): Host reset input. (Active Low).
4. Disable ports (TP14): When this pin is pulled down, the PSE activity is off (Active Low)
5. xSys_ok (TP15): System validity indication. The behavior of this output is controlled by individual software mask. (Active Low).

Note: All the TPs in the preceding list are referenced to the PD77020 domain (GND_HOST).

The placement of the test points in the evaluation board is as shown in the following figure.

Figure 1-10. Test Points



1.3 LED Indication

The evaluation board contains status indication LED. These LEDs and their corresponding functions are listed in the following table.

Table 1-2. LED List

Designation	Function
D1	Isolated 3.3 V _{DC} ON (powers the PD77020, reset, LED stream, USB comm)
D2	3.3 V _{DC} ON (powers the two PD7728)
D4	V _{MAIN} ON
D5	Interrupt out (active low)
D6	System OK (active low)
Port (0-7)	Green and yellow LED per port: <ul style="list-style-type: none"> • LED OFF= Port is OFF • Green LED on= 4-pair port is on • Yellow LED on= 2-pair port is on • LED blinking= Port is OFF due to error/under load/ power management

1.4 RJ45 Connectors Polarity

The eight ports of J6 and J7 are 4-pair up to 90W each. The polarity of the port is listed in the following table.

Table 1-3. J6 and J7/RJ45 Connector 4-Pair Port (Ports 0-7)

Pin Number (Each RJ45 Port)	Polarity
1, 2	Negative Alt A
3, 6	Positive Alt A
4, 5	Positive Alt B
7, 8	Negative Alt B

See the following figure for port numbering.

Figure 1-11. Port Numbering

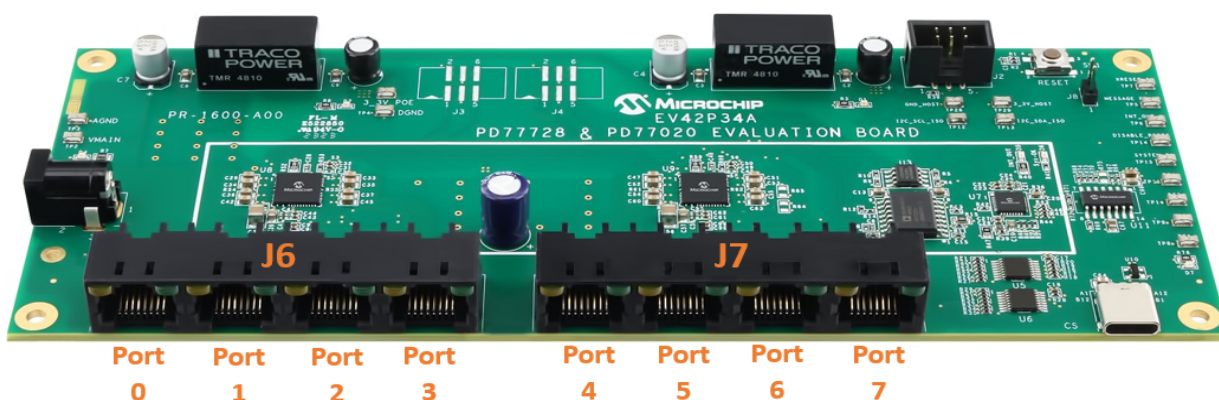

2. Installation and Setting

This section describes the steps required to install and operate the EVB. Take the following precautions before starting the installation:

- Ensure that the 52 V_{DC}- 57V_{DC} power supply of the board is turned off before plugging in the DC connector
- Turn the main power supply on only after the DC connector is plugged in
- Ensure the correct polarity of the power supply cable. The polarity of the power supply cable is as shown in [Figure 1-1](#).

2.1 Schematics

Contact Microchip for the full-board schematics.

3. Revision History

The revision history describes the changes that were implemented in the document. The changes are listed by revision, starting with the most current publication.

Table 3-1. Revision History

Revision	Date	Description
A	04/2024	Initial release

Microchip Information

The Microchip Website

Microchip provides online support via our website at www.microchip.com/. This website is used to make files and information easily available to customers. Some of the content available includes:

- **Product Support** – Data sheets and errata, application notes and sample programs, design resources, user’s guides and hardware support documents, latest software releases and archived software
- **General Technical Support** – Frequently Asked Questions (FAQs), technical support requests, online discussion groups, Microchip design partner program member listing
- **Business of Microchip** – Product selector and ordering guides, latest Microchip press releases, listing of seminars and events, listings of Microchip sales offices, distributors and factory representatives

Product Change Notification Service

Microchip’s product change notification service helps keep customers current on Microchip products. Subscribers will receive email notification whenever there are changes, updates, revisions or errata related to a specified product family or development tool of interest.

To register, go to www.microchip.com/pcn and follow the registration instructions.

Customer Support

Users of Microchip products can receive assistance through several channels:

- Distributor or Representative
- Local Sales Office
- Embedded Solutions Engineer (ESE)
- Technical Support

Customers should contact their distributor, representative or ESE for support. Local sales offices are also available to help customers. A listing of sales offices and locations is included in this document.

Technical support is available through the website at: www.microchip.com/support

Microchip Devices Code Protection Feature

Note the following details of the code protection feature on Microchip products:

- Microchip products meet the specifications contained in their particular Microchip Data Sheet.
- Microchip believes that its family of products is secure when used in the intended manner, within operating specifications, and under normal conditions.
- Microchip values and aggressively protects its intellectual property rights. Attempts to breach the code protection features of Microchip product is strictly prohibited and may violate the Digital Millennium Copyright Act.
- Neither Microchip nor any other semiconductor manufacturer can guarantee the security of its code. Code protection does not mean that we are guaranteeing the product is “unbreakable”. Code protection is constantly evolving. Microchip is committed to continuously improving the code protection features of our products.

Legal Notice

This publication and the information herein may be used only with Microchip products, including to design, test, and integrate Microchip products with your application. Use of this information in any other manner violates these terms. Information regarding device applications is provided only for your convenience and may be superseded by updates. It is your responsibility to ensure

that your application meets with your specifications. Contact your local Microchip sales office for additional support or, obtain additional support at www.microchip.com/en-us/support/design-help/client-support-services.

THIS INFORMATION IS PROVIDED BY MICROCHIP "AS IS". MICROCHIP MAKES NO REPRESENTATIONS OR WARRANTIES OF ANY KIND WHETHER EXPRESS OR IMPLIED, WRITTEN OR ORAL, STATUTORY OR OTHERWISE, RELATED TO THE INFORMATION INCLUDING BUT NOT LIMITED TO ANY IMPLIED WARRANTIES OF NON-INFRINGEMENT, MERCHANTABILITY, AND FITNESS FOR A PARTICULAR PURPOSE, OR WARRANTIES RELATED TO ITS CONDITION, QUALITY, OR PERFORMANCE.

IN NO EVENT WILL MICROCHIP BE LIABLE FOR ANY INDIRECT, SPECIAL, PUNITIVE, INCIDENTAL, OR CONSEQUENTIAL LOSS, DAMAGE, COST, OR EXPENSE OF ANY KIND WHATSOEVER RELATED TO THE INFORMATION OR ITS USE, HOWEVER CAUSED, EVEN IF MICROCHIP HAS BEEN ADVISED OF THE POSSIBILITY OR THE DAMAGES ARE FORESEEABLE. TO THE FULLEST EXTENT ALLOWED BY LAW, MICROCHIP'S TOTAL LIABILITY ON ALL CLAIMS IN ANY WAY RELATED TO THE INFORMATION OR ITS USE WILL NOT EXCEED THE AMOUNT OF FEES, IF ANY, THAT YOU HAVE PAID DIRECTLY TO MICROCHIP FOR THE INFORMATION.

Use of Microchip devices in life support and/or safety applications is entirely at the buyer's risk, and the buyer agrees to defend, indemnify and hold harmless Microchip from any and all damages, claims, suits, or expenses resulting from such use. No licenses are conveyed, implicitly or otherwise, under any Microchip intellectual property rights unless otherwise stated.

Trademarks

The Microchip name and logo, the Microchip logo, Adaptec, AVR, AVR logo, AVR Freaks, BesTime, BitCloud, CryptoMemory, CryptoRF, dsPIC, flexPWR, HELDO, IGLOO, JukeBlox, KeeLoq, Kleer, LANCheck, LinkMD, maXStylus, maXTouch, MediaLB, megaAVR, Microsemi, Microsemi logo, MOST, MOST logo, MPLAB, OptoLyzer, PIC, picoPower, PICSTART, PIC32 logo, PolarFire, Prochip Designer, QTouch, SAM-BA, SenGenuity, SpyNIC, SST, SST Logo, SuperFlash, Symmetricom, SyncServer, Tachyon, TimeSource, tinyAVR, UNI/O, Vectron, and XMEGA are registered trademarks of Microchip Technology Incorporated in the U.S.A. and other countries.

AgileSwitch, ClockWorks, The Embedded Control Solutions Company, EtherSynch, Flashtec, Hyper Speed Control, HyperLight Load, Libero, motorBench, mTouch, Powermite 3, Precision Edge, ProASIC, ProASIC Plus, ProASIC Plus logo, Quiet-Wire, SmartFusion, SyncWorld, TimeCesium, TimeHub, TimePictra, TimeProvider, and ZL are registered trademarks of Microchip Technology Incorporated in the U.S.A.

Adjacent Key Suppression, AKS, Analog-for-the-Digital Age, Any Capacitor, AnyIn, AnyOut, Augmented Switching, BlueSky, BodyCom, Clockstudio, CodeGuard, CryptoAuthentication, CryptoAutomotive, CryptoCompanion, CryptoController, dsPICDEM, dsPICDEM.net, Dynamic Average Matching, DAM, ECAN, Espresso T1S, EtherGREEN, EyeOpen, GridTime, IdealBridge, IGaT, In-Circuit Serial Programming, ICSP, INICnet, Intelligent Paralleling, IntelliMOS, Inter-Chip Connectivity, JitterBlocker, Knob-on-Display, MarginLink, maxCrypto, maxView, memBrain, Mindi, MiWi, MPASM, MPF, MPLAB Certified logo, MPLIB, MPLINK, mSiC, MultiTRAK, NetDetach, Omniscient Code Generation, PICDEM, PICDEM.net, PICkit, PICtail, Power MOS IV, Power MOS 7, PowerSmart, PureSilicon, QMatrix, REAL ICE, Ripple Blocker, RTAX, RTG4, SAM-ICE, Serial Quad I/O, simpleMAP, SimpliPHY, SmartBuffer, SmartHLS, SMART-I.S., storClad, SQI, SuperSwitcher, SuperSwitcher II, Switchtec, SynchroPHY, Total Endurance, Trusted Time, TSHARC, Turing, USBCheck, VariSense, VectorBlox, VeriPHY, ViewSpan, WiperLock, XpressConnect, and ZENA are trademarks of Microchip Technology Incorporated in the U.S.A. and other countries.

SQTP is a service mark of Microchip Technology Incorporated in the U.S.A.

The Adaptec logo, Frequency on Demand, Silicon Storage Technology, and Symmcom are registered trademarks of Microchip Technology Inc. in other countries.

GestIC is a registered trademark of Microchip Technology Germany II GmbH & Co. KG, a subsidiary of Microchip Technology Inc., in other countries.

All other trademarks mentioned herein are property of their respective companies.

© 2024, Microchip Technology Incorporated and its subsidiaries. All Rights Reserved.

ISBN: 978-1-6683-4326-5

Quality Management System

For information regarding Microchip's Quality Management Systems, please visit www.microchip.com/quality.

Worldwide Sales and Service

AMERICAS	ASIA/PACIFIC	ASIA/PACIFIC	EUROPE
<p>Corporate Office 2355 West Chandler Blvd. Chandler, AZ 85224-6199 Tel: 480-792-7200 Fax: 480-792-7277 Technical Support: www.microchip.com/support Web Address: www.microchip.com</p> <p>Atlanta Duluth, GA Tel: 678-957-9614 Fax: 678-957-1455</p> <p>Austin, TX Tel: 512-257-3370</p> <p>Boston Westborough, MA Tel: 774-760-0087 Fax: 774-760-0088</p> <p>Chicago Itasca, IL Tel: 630-285-0071 Fax: 630-285-0075</p> <p>Dallas Addison, TX Tel: 972-818-7423 Fax: 972-818-2924</p> <p>Detroit Novi, MI Tel: 248-848-4000</p> <p>Houston, TX Tel: 281-894-5983</p> <p>Indianapolis Noblesville, IN Tel: 317-773-8323 Fax: 317-773-5453 Tel: 317-536-2380</p> <p>Los Angeles Mission Viejo, CA Tel: 949-462-9523 Fax: 949-462-9608 Tel: 951-273-7800</p> <p>Raleigh, NC Tel: 919-844-7510</p> <p>New York, NY Tel: 631-435-6000</p> <p>San Jose, CA Tel: 408-735-9110 Tel: 408-436-4270</p> <p>Canada - Toronto Tel: 905-695-1980 Fax: 905-695-2078</p>	<p>Australia - Sydney Tel: 61-2-9868-6733</p> <p>China - Beijing Tel: 86-10-8569-7000</p> <p>China - Chengdu Tel: 86-28-8665-5511</p> <p>China - Chongqing Tel: 86-23-8980-9588</p> <p>China - Dongguan Tel: 86-769-8702-9880</p> <p>China - Guangzhou Tel: 86-20-8755-8029</p> <p>China - Hangzhou Tel: 86-571-8792-8115</p> <p>China - Hong Kong SAR Tel: 852-2943-5100</p> <p>China - Nanjing Tel: 86-25-8473-2460</p> <p>China - Qingdao Tel: 86-532-8502-7355</p> <p>China - Shanghai Tel: 86-21-3326-8000</p> <p>China - Shenyang Tel: 86-24-2334-2829</p> <p>China - Shenzhen Tel: 86-755-8864-2200</p> <p>China - Suzhou Tel: 86-186-6233-1526</p> <p>China - Wuhan Tel: 86-27-5980-5300</p> <p>China - Xian Tel: 86-29-8833-7252</p> <p>China - Xiamen Tel: 86-592-2388138</p> <p>China - Zhuhai Tel: 86-756-3210040</p>	<p>India - Bangalore Tel: 91-80-3090-4444</p> <p>India - New Delhi Tel: 91-11-4160-8631</p> <p>India - Pune Tel: 91-20-4121-0141</p> <p>Japan - Osaka Tel: 81-6-6152-7160</p> <p>Japan - Tokyo Tel: 81-3-6880-3770</p> <p>Korea - Daegu Tel: 82-53-744-4301</p> <p>Korea - Seoul Tel: 82-2-554-7200</p> <p>Malaysia - Kuala Lumpur Tel: 60-3-7651-7906</p> <p>Malaysia - Penang Tel: 60-4-227-8870</p> <p>Philippines - Manila Tel: 63-2-634-9065</p> <p>Singapore Tel: 65-6334-8870</p> <p>Taiwan - Hsin Chu Tel: 886-3-577-8366</p> <p>Taiwan - Kaohsiung Tel: 886-7-213-7830</p> <p>Taiwan - Taipei Tel: 886-2-2508-8600</p> <p>Thailand - Bangkok Tel: 66-2-694-1351</p> <p>Vietnam - Ho Chi Minh Tel: 84-28-5448-2100</p>	<p>Austria - Wels Tel: 43-7242-2244-39 Fax: 43-7242-2244-393</p> <p>Denmark - Copenhagen Tel: 45-4485-5910 Fax: 45-4485-2829</p> <p>Finland - Espoo Tel: 358-9-4520-820</p> <p>France - Paris Tel: 33-1-69-53-63-20 Fax: 33-1-69-30-90-79</p> <p>Germany - Garching Tel: 49-8931-9700</p> <p>Germany - Haan Tel: 49-2129-3766400</p> <p>Germany - Heilbronn Tel: 49-7131-72400</p> <p>Germany - Karlsruhe Tel: 49-721-625370</p> <p>Germany - Munich Tel: 49-89-627-144-0 Fax: 49-89-627-144-44</p> <p>Germany - Rosenheim Tel: 49-8031-354-560</p> <p>Israel - Ra'anana Tel: 972-9-744-7705</p> <p>Italy - Milan Tel: 39-0331-742611 Fax: 39-0331-466781</p> <p>Italy - Padova Tel: 39-049-7625286</p> <p>Netherlands - Drunen Tel: 31-416-690399 Fax: 31-416-690340</p> <p>Norway - Trondheim Tel: 47-72884388</p> <p>Poland - Warsaw Tel: 48-22-3325737</p> <p>Romania - Bucharest Tel: 40-21-407-87-50</p> <p>Spain - Madrid Tel: 34-91-708-08-90 Fax: 34-91-708-08-91</p> <p>Sweden - Gothenberg Tel: 46-31-704-60-40</p> <p>Sweden - Stockholm Tel: 46-8-5090-4654</p> <p>UK - Wokingham Tel: 44-118-921-5800 Fax: 44-118-921-5820</p>